

Smart Sensor (Wide Laser Beam CCD Measurement Sensor) ZX-GT

CSM_ZX-GT_DS_E_1_1

Achieves Micron Accuracy with Longest-in-Class Sensing Distance

- Maximum sensing distance of 500 mm and measuring width of 28 mm provide a wide area.
- 10- μ m accuracy anywhere within the area, even though the sensor uses a non-contact method.
- Stable detection of even transparent glass and mirror surfaces.
- Compact sensor and controller provide minimal installation space requirements.



Refer to *Safety Precautions* on page 8.

For the most recent information on models that have been certified for safety standards, refer to your OMRON website.

Features

Maximum 500-mm area Measurable at any position

Measurements can be consistently taken within a wide area, whatever stage the work is at or whichever way it is inserted. It can now be set to positions without interference from the work feed and without limitations of size of work area.

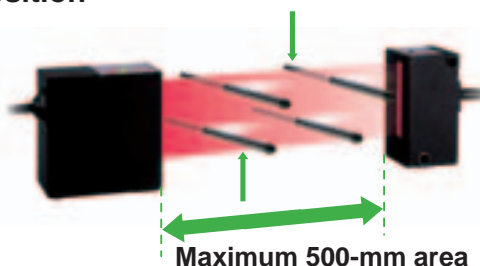

Accurate! 10- μ m by non-contact method

ZX-GT is the only sensor with the ability to measure and locate position to an accuracy of 10 μ m without contact. Unlike conventional through-beam laser sensors, the ZX-GT's unique algorithm has the flexibility to meet a wide variety of applications, including the ability to accurately measure glass and mirror surfaces.

Small! Compact like palm-top



Compact sensor head that can be set in the gap between equipment.



Its compact controller is a continuation of the ZX series.

New concept "TRIO" 1/7 in speed compared with conventional products

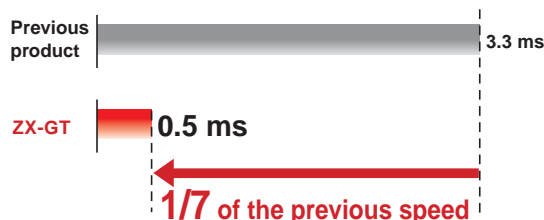

With OMRON'S unique TRIO (Triple parallel processing) algorithm, it is possible to take 2000 high-speed samples per second, 7 times greater than previously possible, greatly reducing tact time.



Ordering Information

Sensors

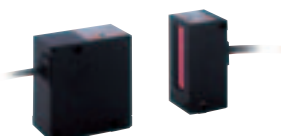
Sensor Head (Dimensions → page 8)

Appearance	Optical system	Measuring width	Sensing distance	Resolution	Output type	Model
Emitter and receiver, separate type 	Through-beam	28 mm	0 to 500 mm	10 μm	NPN	ZX-GT28S11
			PNP		ZX-GT28S41	
Emitter and receiver, integrated type 		40 mm	NPN		ZX-GT2840S11	
		PNP	ZX-GT2840S41			

Controller (Dimensions → page 8)

Appearance	Power supply	Output type	Model
	DC	NPN	ZX-GTC11
		PNP	ZX-GTC41

Accessories (Order Separately) These are not included with the sensor and controller, so order these accessories separately if necessary.

Set: Interface Unit (RS-232C/Binary output) and PC Setup Software

Output configuration	Model
NPN	ZX-GIF11A
PNP	ZX-GIF41A

Interface Unit (RS-232C/Binary output) (Dimensions → page 8)

Appearance	Power supply	Output type	Model
	DC	NPN	ZX-GIF11
		PNP	ZX-GIF41

Setup software PCs

Name	Model
Smart Monitor GT	ZX-GSW11

Calculating Units (Dimensions → page 8)

Appearance	Model
	ZX-CAL2

Receiver-Controller Extension Cable (Dimensions → page 8)

Cable length	Model		Quantity
	Standard cable	Flexible cable	
1 m	ZX-XGC1A	ZX-XGC1R	1
2 m	ZX-XGC2A	ZX-XGC2R	
5 m	ZX-XGC5A	ZX-XGC5R	
8 m	ZX-XGC8A	ZX-XGC8R	
20 m	ZX-XGC20A	ZX-XGC20R	

Note: Up to two extension cables can be connected.

However, be sure to limit the total extension cable length between the receiver and the Controller to 30 meters (including the receiver cable).

Leading Technology and CCD Processing Algorithm That Support Stable Measurements

Thoroughly eliminating the effect of the ambient temperature

It is important to eliminate the influence of temperature to ensure the accuracy of a measurement. However, the temperature in the field environment changes according to the time and the season. With the ZX-GT, which employs CCD method, the influence on the resolution from temperature changes is greatly reduced leading to an error rate as low as 0.01% (2.8 micro-meters *).

* This is a representative case. Please see the specifications table for the details of the relevant conditions.

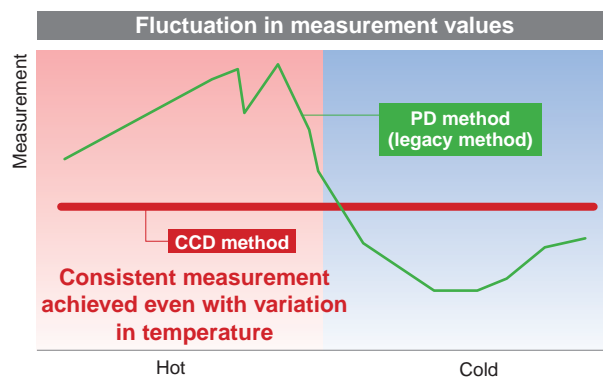

Transparent object detection possible **Integrated MRC filter**

The detection of edges has been a problem for transparent objects with traditional transmission type sensors. However, ZX-GT adopts OMRON's unique MRC filter * (Mirror Reflection Cut Filter) and CCD methodology. It can accurately detect work that reflects light such as mirror-finished surface or work that allows light to pass through such as glass (including coated glass).

* MRC Filter: OMRON's proprietary optical filter.

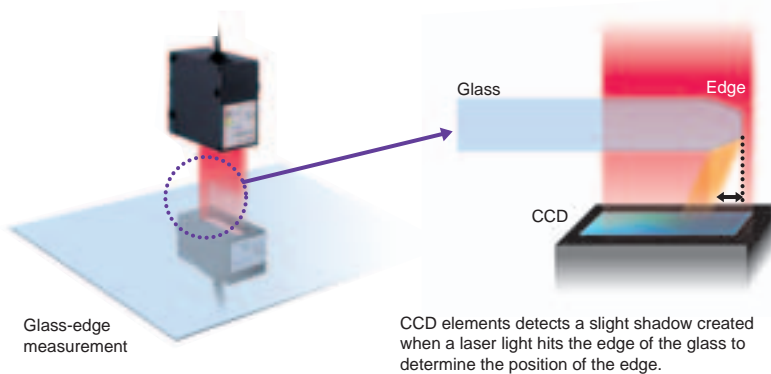

Even effective with mirror finished surfaces



Collimate optical technology

Super parallel-beam

With OMRON's unique collimate optical technology *, the closest to ideal parallel beam is created. Errors are controlled in the measurement area and the longest and most accurate measurement is achieved.

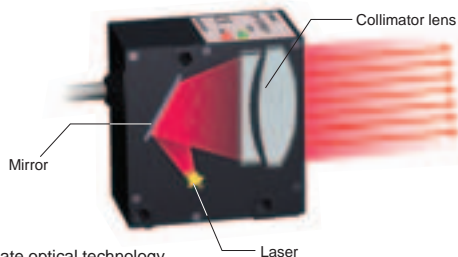

* Collimate optical technology
Collimate optical technology allows laser lights to stay parallel using mirror reflection and lens refraction effects, to take advantage of the laser light's high-level of directivity.

Sub-pixel processing

CCD processing algorithm

CCD detects the shadow made from measurement objects and by performing sub-pixel calculation, it achieves 10 micrometer level accuracy.

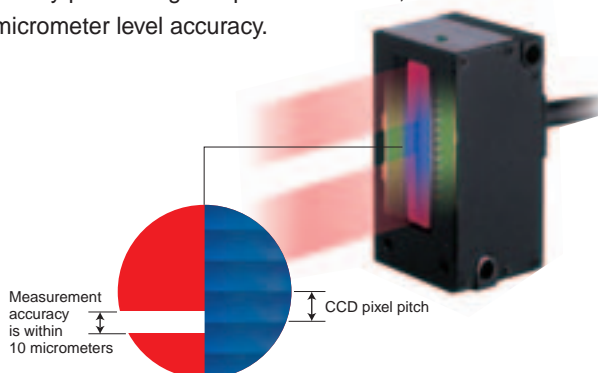

New Concept “Smart Recipe”

Using the PC software 'Smart-monitor GT', set up is easy with simply clicking the icons. This is OMRON's Smart Recipe methodology.

Interface Unit
By connecting it to the controller, RS-232C communication and binary output is possible.

Controller

Easy to set-up
Different features are organized by tabs, to allow the user to understand and change the settings easily. Measurement conditions can be saved on PCs.

Advanced support for data collection and analysis

The measurement data is gathered in the PCs in real time so it is easy to ascertain and analyse the current conditions at any time.

●Grasp the data trend and prevent defective parts

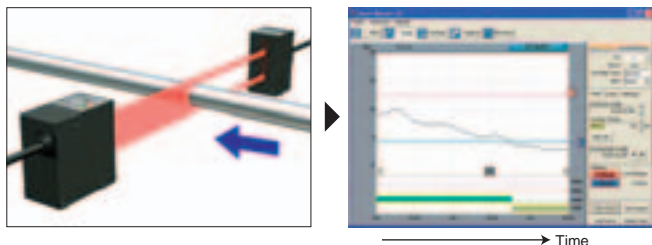

The trend of the measurement data and sudden change can be checked in the time-dependent graph, so that the appropriate action can be taken before defective goods are produced.

●Measurement result can be logged at appropriate times

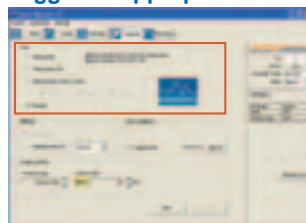

The logged data can be sent to Excel. It is useful for traceability management and for preparing quality assurance reports.

Easy to use, even from a distance

First in the industry 3-way optical axis adjustment

Three optical axis adjustment functions are integrated for the industry's longest measurement. This function provides the optimal adjustment when the sensor head is installed on-site.

With the sensor-head



LED on the light-receiving device is lit up to indicate when the light axis is matched.

With the controller



The CCD light reception balance is displayed in the upper display and the amount of light received can be confirmed with numerical values underneath.

With the PC



The direction of the sensor head's adjustment is graphically displayed. The adjustment conditions can be confirmed through the shapes of the light reception waveforms.

Longest in the industry 30-m cable extension

The emitter and receiver do not need to be connected with each other. Each cable can be extended up to 30 m. It is perfectly suited for installation into large-scale production line.

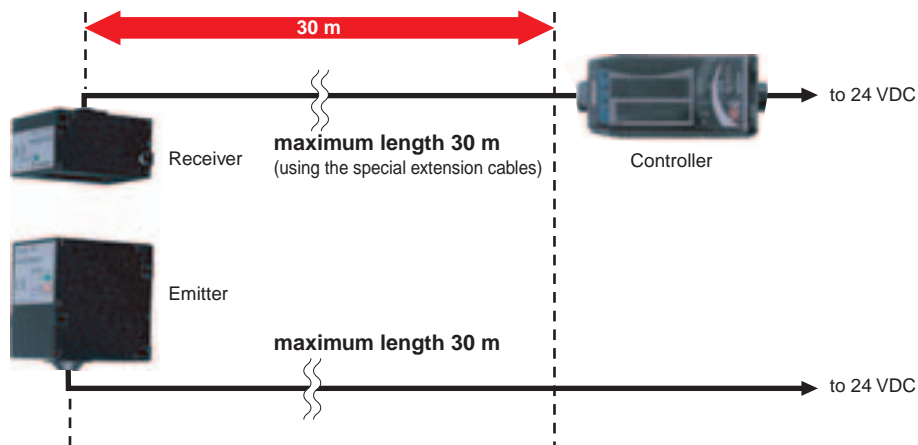

Ratings and Specifications

Sensor Head

Item	Model	ZX-GT28S11	ZX-GT2840S11	ZX-GT28S41	ZX-GT2840S41
Output type		NPN		PNP	
Appearance		Separate type	Integrated type	Separate type	Integrated type
Light source		Visible semiconductor laser diode (wavelength 650 nm, CLASS 1 of EN60825-1/IEC60825-1, CLASS II of FDA (21CFR 1040.10 and 1040.11))			
Measuring width		28 mm			
Sensing distance		0 to 500 mm	40 mm	0 to 500 mm	40 mm
Minimum sensing object		0.5 mm dia. *1	0.2 mm dia.	0.5 mm dia. *1	0.2 mm dia.
Linearity		±0.1%F.S. *2			
Resolution		10 μm (number of process values to average: 16) *3			
Temperature characteristic		0.01%F.S/°C *4			
Indicators (emitter)		Laser ON indicator (green), laser alarm indicator (red)			
Indicators (receiver)		Optical axis setting indicator (green)			
Laser OFF input/sync input		ON: Short-circuited with 0 V or 1.5 V max. OFF: Open (leakage current: 0.1 mA max.)		ON: Short-circuited with power supply voltage or power supply voltage -1.5 V max. OFF: Open (leakage current: 0.1 mA max.)	
Laser deterioration alarm output		NPN open-collector output 30 VDC 20 mA max. Residual voltage 1.2 V max.		PNP open-collector output 30 VDC 20 mA max. Residual voltage 2 V max.	
Power consumption (emitter)		30 mA max.			
Power supply voltage (emitter)		24 VDC +10%, -15% ripple (p-p) 10% max.			
Dielectric strength		1,000 VAC, 50/60 Hz for 1 min			
Insulation resistance		20 MΩ (at 500 VDC)			
Operating ambient illumination (emitter)		3,000 lx (incandescent light)			
Operating ambient illumination (receiver)		1,000 lx (incandescent light) *5			
Ambient temperature		Operating: 0 to 40°C Storage: -15 to 50°C (with no icing or condensation)			
Ambient humidity		Operating and storage: 35% to 85% (with no condensation)			
Vibration resistance (durability)		10 to 150 Hz Single-amplitude: 0.75 mm for 80 min each in X, Y and Z directions			
Shock resistance (durability)		300 m/s ² 3 times each in six directions (up/down, left/right, forward/backward)			
Degree of protection		IEC60529 IP40			
Cable length		2 m			
Material		Case: aluminum die-cast, Lens: glass			
Weight (packed state)		Approx. 550 g	Approx. 570 g	Approx. 550 g	Approx. 570 g
Accessories		Laser warning labels, Instruction Sheet			

F.S.: 28 mm measuring range of receiver

- *1. Distance between emitter and receiver: 500 mm, measurement object at 250 mm from receiver.
Glass ends of chamfer 0.1 mm or more can be detected in glass edge measurement mode. (at binary level 70%)
- *2. Linearity is given to be a typical error with respect to an ideal straight line when the distance between the emitter and receiver is 100 mm and light is blocked at a distance of 50 mm from the receiver.
(On the ZX-GT2840□□, the measurement object is measured at a distance of 20 mm from the receiver.)
- *3. The amount of fluctuation (±3σ) in the analog output when the distance between the emitter and receiver is 100 mm and a ZX-GTC□□ is connected
- *4. Change in the light cutoff value on one side when the distance between the emitter and receiver is 100 mm and the light is half-cutoff at a distance of 50 mm from the receiver
(On the ZX-GT2840□□, the measurement object is measured at a distance of 20 mm from the receiver.)
- *5. Standard mode (NORM) used

Controller

Item	Model	ZX-GTC11	ZX-GTC41
Output type		NPN	PNP
Measurement cycle *1		1.5 ms (standard mode (NORM)) 0.5 ms (high-speed mode (FAST)) *2	
Samples to average		1/2/4/8/16/32/64/128/256/512/1,024/2,048/4,096	
Analog output *3		For current output: 4 to 20 mA/F.S., max. load resistance 300 Ω For voltage output: ±4 V, (±5 V, 1 to 5 V *4), output impedance 100 Ω	
Timing input, bank switching input, zero reset input, reset input		ON: short-circuited with 0 V or 1.5 V max. OFF: Open (leakage current: 0.1 mA max.)	ON: short-circuited with power supply voltage or power supply voltage -1.5 V max. OFF: Open (leakage current: 0.1 mA max.)
HIGH/PASS/LOW Judgment output *5 Sync output *6		NPN open-collector output 30 VDC 50 mA max. Residual voltage 1.2 V max.	PNP open-collector output 30 VDC 50 mA max. Residual voltage 2 V max.
Indicator		Judgment output indicator: HIGH (orange), PASS (green), LOW (orange) Main display (red) Sub-display (yellow) Bank 1/2 (orange), zero reset (green)	
Main functions	Number of registered setups	2 banks	
	Measurement Mode	Interrupted beam width measurement, incident beam width measurement, outer diameter measurement, center position measurement, IC lead pitch, IC lead width judgment, specified edge measurement, wire position measurement, glass edge position measurement	
	Display during measurement	Measured value, resolution, threshold, voltage output value, current output value (number of display digits can be changed)	
	Zero reset functions	Offset setting of zero reset value, zero reset value memory	
	Hold	Sample hold, peak hold, bottom hold, peak-to-peak hold, average hold, delay hold	
	Timer functions	ON delay, OFF delay, one-shot	
	Adjustment functions	Optical Axis adjust mode/light intensity writing mode, variable binary level, variable edge filter, analog output scaling	
Calculation	2 Possible on up to two Controllers (Calculation Unit ZX-CAL2 is required for connecting Controllers to each other.) A-B, A+B, width		
Other	Measurement cycle setting, threshold setting, hysteresis setting, initialization, key lock		
Temperature characteristic		0.005%F.S./°C	
Current consumption		150 mA max. (including receiver)	
Power supply voltage		24 VDC +10%, -15% ripple (p-p) 10% max.	
Dielectric strength		1,000 VAC, 50/60 Hz for 1 min	
Insulation resistance		20 MΩ (at 500 VDC)	
Ambient temperature		Operating: 0 to 50°C Storage: -15 to 60°C (with no icing or condensation)	
Ambient humidity		Operating and storage: 35% to 85% (with no condensation)	
Vibration resistance (durability)		10 to 150 Hz Single-amplitude: 0.35 mm for 80 min each in X, Y and Z directions	
Shock resistance (durability)		300 m/s ² 3 times each in six directions (up/down, left/right, forward/backward)	
Degree of protection		IEC60529 IP20	
Cable length		2 m	
Material		Case: PBT (polybutylene terephthalate), Cover: Polycarbonate	
Weight (packed state)		Approx. 330 g	
Accessories		Instruction Sheet	

- *1. A simple average is used in IC lead pitch judgment mode or IC lead width judgment mode.
The measurement cycle time can be calculated as follows: Specified measurement cycle time × (Number of samples to average + 1) + 1 ms max.
In other measurement modes, a moving average is used. The first measurement cycle time can be calculated as follows: Specified measurement cycle time × (Number of samples to average + 1) + 1 ms max. The second and later measurement cycle times will be equal to the specified measurement cycle time.
- *2. The response time in the high-speed mode (FAST) for the IC lead pitch and IC lead width judgment modes is 1 ms.

- *3. Current/voltage can be switched using the switch provided on the rear of the Controller.
*4. Can be set by the analog output scaling function.
*5. The error (ERR) state is displayed when all HIGH/PASS/LOW outputs turn OFF.
*6. Normally, wire the sync output wire directly to the emitter's sync input wire and run the Controller in the standard mode. On an NPN type Controller, use an NPN type emitter, and on a PNP type Controller, use a PNP type emitter. Wiring of the sync wires is not required when the Controller is run in the high-speed mode. (Note, however, that the Controller becomes more susceptible to the influence of ambient light in this case.)

Interface Unit

Item	Model	ZX-GIF11-GIF11A	ZX-GIF41-GIF41A
Compatible Controller		ZX-GTC11	ZX-GTC41
Indicator		Power ON (green), Controller communications (orange), Controller communications error (red), RS-232C communications (orange), RS-232C communications error (red), binary output (orange)	
Communications port		RS-232C (9-pin D-sub connector)	
12-bit binary output (D11 to D0, GATE)		NPN open-collector output 30 VDC 20mA max. Residual voltage 1.2 V max.	PNP open-collector output 30 VDC 20 mA max. Residual voltage 2 V max.
Power supply voltage		Supplied from Controller (power consumption: 60 mA max.)	
Dielectric strength		1,000 VAC, 50/60 Hz for 1 min	
Insulation resistance		20 MΩ (at 500 VDC)	
Ambient temperature		Operating: 0 to 50°C Storage: -15 to 60°C (with no icing or condensation)	
Ambient humidity		Operating and storage: 35% to 85% (with no condensation)	
Vibration resistance (durability)		10 to 150 Hz Single-amplitude: 0.35 mm for 80 min each in X, Y and Z directions	
Shock resistance (durability)		300 m/s ² 3 times each in six directions (up/down, left/right, forward/backward)	
Degree of protection		IEC60529 IP20	
Cable length		RS-232C 0.5 m, binary output 2 m	
Materials		Case: PBT (polybutylene terephthalate), Cover: Polycarbonate	
Weight (packed state)		ZX-GIF□1A: Approx. 550 g ZX-GIF□1: Approx. 330 g	
Accessories		ZX-GIF□1A: Setup Software (CD-ROM), 2 clamps, Instruction Sheet ZX-GIF□1: 2 clamps, Instruction Sheet	

Safety Precautions

Refer to the *Technical Guide*.

WARNING

This product is not designed or rated for ensuring safety of persons either directly or indirectly. Do not use it for such purposes.



CAUTION

Never look into the laser beam. Doing so continuously will result in visual impairment.



Do not attempt to dismantle, pressurize, or incinerate the product. Doing so may cause the laser beam to leak, resulting in the danger of visual impairment.



For details on information such as the usage precautions → refer to the *ZX-GT Series Smart Sensor User's Manual* (Cat. No.: Z263).

Dimensions

(Unit: mm)

Tolerance class IT16 applies to dimensions in this data sheet unless otherwise specified.

Sensor Head

Separate type: ZX-GT28S11/GT28S41

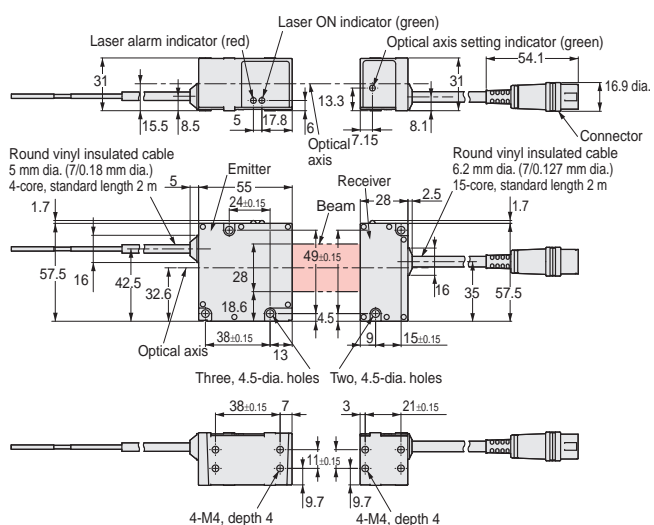

Integrated type: ZX-GT2840S11/GT2840S41

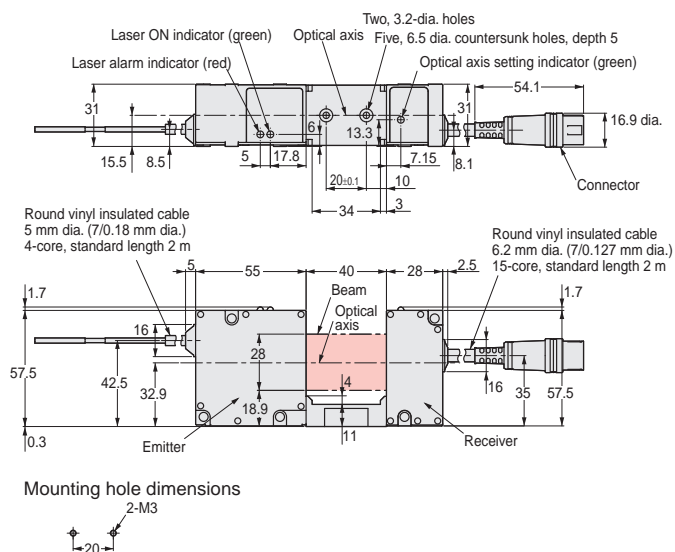

Controller

ZX-GTC11/GTC41

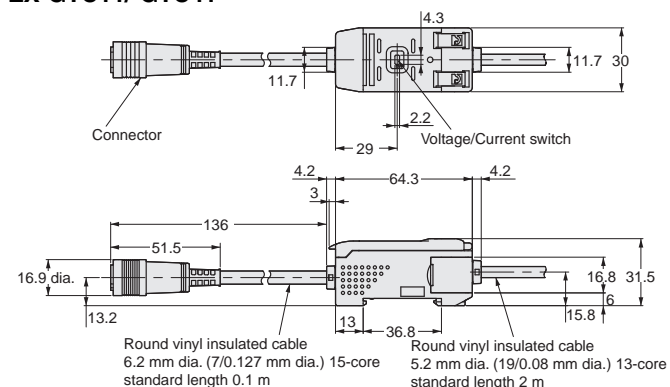

Interface Unit

ZX-GIF11/GIF41

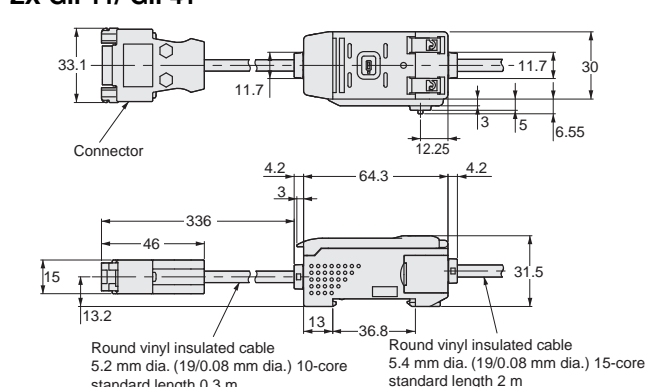

Calculating Unit

ZX-CAL2

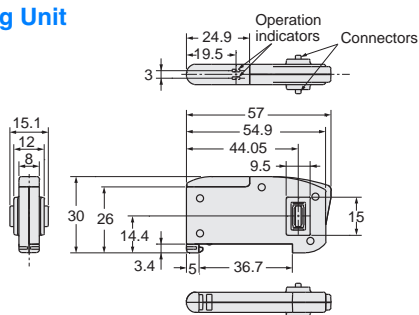

Receiver-Controller Extension Cable

ZX-XGC□A/XGC□R

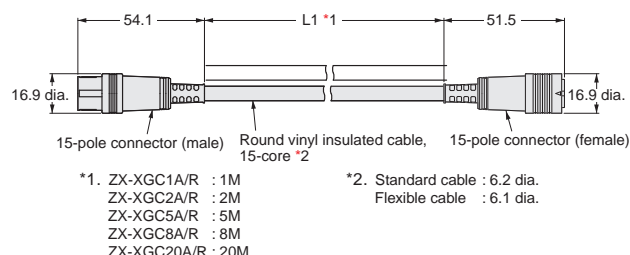

Terms and Conditions Agreement

Read and understand this catalog.

Please read and understand this catalog before purchasing the products. Please consult your OMRON representative if you have any questions or comments.

Warranties.

(a) Exclusive Warranty. Omron's exclusive warranty is that the Products will be free from defects in materials and workmanship for a period of twelve months from the date of sale by Omron (or such other period expressed in writing by Omron). Omron disclaims all other warranties, express or implied.

(b) Limitations. OMRON MAKES NO WARRANTY OR REPRESENTATION, EXPRESS OR IMPLIED, ABOUT NON-INFRINGEMENT, MERCHANTABILITY OR FITNESS FOR A PARTICULAR PURPOSE OF THE PRODUCTS. BUYER ACKNOWLEDGES THAT IT ALONE HAS DETERMINED THAT THE PRODUCTS WILL SUITABLY MEET THE REQUIREMENTS OF THEIR INTENDED USE.

Omron further disclaims all warranties and responsibility of any type for claims or expenses based on infringement by the Products or otherwise of any intellectual property right. (c) Buyer Remedy. Omron's sole obligation hereunder shall be, at Omron's election, to (i) replace (in the form originally shipped with Buyer responsible for labor charges for removal or replacement thereof) the non-complying Product, (ii) repair the non-complying Product, or (iii) repay or credit Buyer an amount equal to the purchase price of the non-complying Product; provided that in no event shall Omron be responsible for warranty, repair, indemnity or any other claims or expenses regarding the Products unless Omron's analysis confirms that the Products were properly handled, stored, installed and maintained and not subject to contamination, abuse, misuse or inappropriate modification. Return of any Products by Buyer must be approved in writing by Omron before shipment. Omron Companies shall not be liable for the suitability or unsuitability or the results from the use of Products in combination with any electrical or electronic components, circuits, system assemblies or any other materials or substances or environments. Any advice, recommendations or information given orally or in writing, are not to be construed as an amendment or addition to the above warranty.

See <http://www.omron.com/global/> or contact your Omron representative for published information.

Limitation on Liability; Etc.

OMRON COMPANIES SHALL NOT BE LIABLE FOR SPECIAL, INDIRECT, INCIDENTAL, OR CONSEQUENTIAL DAMAGES, LOSS OF PROFITS OR PRODUCTION OR COMMERCIAL LOSS IN ANY WAY CONNECTED WITH THE PRODUCTS, WHETHER SUCH CLAIM IS BASED IN CONTRACT, WARRANTY, NEGLIGENCE OR STRICT LIABILITY.

Further, in no event shall liability of Omron Companies exceed the individual price of the Product on which liability is asserted.

Suitability of Use.

Omron Companies shall not be responsible for conformity with any standards, codes or regulations which apply to the combination of the Product in the Buyer's application or use of the Product. At Buyer's request, Omron will provide applicable third party certification documents identifying ratings and limitations of use which apply to the Product. This information by itself is not sufficient for a complete determination of the suitability of the Product in combination with the end product, machine, system, or other application or use. Buyer shall be solely responsible for determining appropriateness of the particular Product with respect to Buyer's application, product or system. Buyer shall take application responsibility in all cases.

NEVER USE THE PRODUCT FOR AN APPLICATION INVOLVING SERIOUS RISK TO LIFE OR PROPERTY OR IN LARGE QUANTITIES WITHOUT ENSURING THAT THE SYSTEM AS A WHOLE HAS BEEN DESIGNED TO ADDRESS THE RISKS, AND THAT THE OMRON PRODUCT(S) IS PROPERLY RATED AND INSTALLED FOR THE INTENDED USE WITHIN THE OVERALL EQUIPMENT OR SYSTEM.

Programmable Products.

Omron Companies shall not be responsible for the user's programming of a programmable Product, or any consequence thereof.

Performance Data.

Data presented in Omron Company websites, catalogs and other materials is provided as a guide for the user in determining suitability and does not constitute a warranty. It may represent the result of Omron's test conditions, and the user must correlate it to actual application requirements. Actual performance is subject to the Omron's Warranty and Limitations of Liability.

Change in Specifications.

Product specifications and accessories may be changed at any time based on improvements and other reasons. It is our practice to change part numbers when published ratings or features are changed, or when significant construction changes are made. However, some specifications of the Product may be changed without any notice. When in doubt, special part numbers may be assigned to fix or establish key specifications for your application. Please consult with your Omron's representative at any time to confirm actual specifications of purchased Product.

Errors and Omissions.

Information presented by Omron Companies has been checked and is believed to be accurate; however, no responsibility is assumed for clerical, typographical or proofreading errors or omissions.