



General-Purpose AC Servo

MITSUBISHI SERVO AMPLIFIERS & MOTORS

MELSERVO-J4

CC-Link IE Field Network Interface

MODEL

MR-J4- _GF_ (-RJ)

SERVO AMPLIFIER

INSTRUCTION MANUAL

(I/O MODE)

● Safety Instructions ●

Please read the instructions carefully before using the equipment.

To use the equipment correctly, do not attempt to install, operate, maintain, or inspect the equipment until you have read through this Instruction Manual, Installation guide, and appended documents carefully. Do not use the equipment until you have a full knowledge of the equipment, safety information and instructions. In this Instruction Manual, the safety instruction levels are classified into "WARNING" and "CAUTION".



Indicates that incorrect handling may cause hazardous conditions, resulting in death or severe injury.



Indicates that incorrect handling may cause hazardous conditions, resulting in medium or slight injury to personnel or may cause physical damage.

Note that the CAUTION level may lead to a serious consequence according to conditions. Please follow the instructions of both levels because they are important to personnel safety. What must not be done and what must be done are indicated by the following diagrammatic symbols.



Indicates what must not be done. For example, "No Fire" is indicated by .



Indicates what must be done. For example, grounding is indicated by .

In this Instruction Manual, instructions at a lower level than the above, instructions for other functions, and so on are classified into "POINT".

After reading this Instruction Manual, keep it accessible to the operator.

1. To prevent electric shock, note the following

WARNING

- Before wiring and inspections, turn off the power and wait for 15 minutes or more until the charge lamp turns off. Then, confirm that the voltage between P+ and N- is safe with a voltage tester and others. Otherwise, an electric shock may occur. In addition, when confirming whether the charge lamp is off or not, always confirm it from the front of the servo amplifier.
- Ground the servo amplifier and servo motor securely.
- Any person who is involved in wiring and inspection should be fully competent to do the work.
- Do not attempt to wire the servo amplifier and servo motor until they have been installed. Otherwise, it may cause an electric shock.
- Do not operate switches with wet hands. Otherwise, it may cause an electric shock.
- The cables should not be damaged, stressed, loaded, or pinched. Otherwise, it may cause an electric shock.
- During power-on or operation, do not open the front cover of the servo amplifier. Otherwise, it may cause an electric shock.
- Do not operate the servo amplifier with the front cover removed. High-voltage terminals and charging area are exposed and you may get an electric shock.
- Except for wiring and periodic inspection, do not remove the front cover of the servo amplifier even if the power is off. The servo amplifier is charged and you may get an electric shock.
- To prevent an electric shock, always connect the protective earth (PE) terminal (marked \oplus) of the servo amplifier to the protective earth (PE) of the cabinet.
- To avoid an electric shock, insulate the connections of the power supply terminals.

2. To prevent fire, note the following

CAUTION

- Install the servo amplifier, servo motor, and regenerative resistor on incombustible material. Installing them directly or close to combustibles will lead to smoke or a fire.
- Always connect a magnetic contactor between the power supply and the main circuit power supply (L1, L2, and L3) of the servo amplifier, in order to configure a circuit that shuts down the power supply on the side of the servo amplifier's power supply. If a magnetic contactor is not connected, continuous flow of a large current may cause smoke or a fire when the servo amplifier malfunctions.
- Always connect a molded-case circuit breaker, or a fuse to each servo amplifier between the power supply and the main circuit power supply (L1, L2, and L3) of the servo amplifier, in order to configure a circuit that shuts down the power supply on the side of the servo amplifier's power supply. If a molded-case circuit breaker or fuse is not connected, continuous flow of a large current may cause smoke or a fire when the servo amplifier malfunctions.
- When using the regenerative resistor, switch power off with the alarm signal. Otherwise, a regenerative transistor malfunction or the like may overheat the regenerative resistor, causing smoke or a fire.
- Provide adequate protection to prevent screws and other conductive matter, oil and other combustible matter from entering the servo amplifier and servo motor.

3. To prevent injury, note the following

CAUTION

- Only the voltage specified in the Instruction Manual should be applied to each terminal. Otherwise, a burst, damage, etc. may occur.
- Connect cables to the correct terminals. Otherwise, a burst, damage, etc. may occur.

⚠ CAUTION

- Ensure that polarity (+/-) is correct. Otherwise, a burst, damage, etc. may occur.
- The servo amplifier heat sink, regenerative resistor, servo motor, etc. may be hot while power is on and for some time after power-off. Take safety measures, e.g. provide covers, to prevent accidental contact of hands and parts (cables, etc.) with them.

4. Additional instructions

The following instructions should also be fully noted. Incorrect handling may cause a fault, injury, electric shock, fire, etc.

(1) Transportation and installation

⚠ CAUTION

- Transport the products correctly according to their mass.
- Stacking in excess of the specified number of product packages is not allowed.
- Do not hold the front cover when transporting the servo amplifier. Otherwise, it may drop.
- Install the servo amplifier and the servo motor in a load-bearing place in accordance with the Instruction Manual.
- Do not get on or put heavy load on the equipment.
- The equipment must be installed in the specified direction.
- Leave specified clearances between the servo amplifier and the cabinet walls or other equipment.
- Do not install or operate the servo amplifier and servo motor which have been damaged or have any parts missing.
- Do not block the intake and exhaust areas of the servo amplifier. Otherwise, it may cause a malfunction.
- Do not drop or strike the servo amplifier and servo motor. Isolate them from all impact loads.
- When you keep or use the equipment, please fulfill the following environment.

Items		Environment
Ambient temperature	Operation	0 °C to 55 °C (non-freezing)
	Storage	-20 °C to 65 °C (non-freezing)
Ambient humidity	Operation	90 %RH or less (non-condensing)
	Storage	
Ambience		Indoors (no direct sunlight), free from corrosive gas, flammable gas, oil mist, dust, and dirt
Altitude		Max. 2000 m above sea level (Contact your local sales office for the altitude for options.)
Vibration resistance		5.9 m/s ² at 10 Hz to 55 Hz (directions of X, Y, and Z axes)

- When the equipment has been stored for an extended period of time, consult your local sales office.
- When handling the servo amplifier, be careful about the edged parts such as corners of the servo amplifier.
- The servo amplifier must be installed in the metal cabinet.
- When fumigants that contain halogen materials such as fluorine, chlorine, bromine, and iodine are used for disinfecting and protecting wooden packaging from insects, they cause malfunction when entering our products. Please take necessary precautions to ensure that remaining materials from fumigant do not enter our products, or treat packaging with methods other than fumigation (heat method). Additionally, disinfect and protect wood from insects before packing products.

(2) Wiring

⚠ CAUTION

- Wire the equipment correctly and securely. Otherwise, the servo motor may operate unexpectedly.
- Do not install a power capacitor, surge killer, or radio noise filter (FR-BIF(-H) option) on the servo amplifier output side.
- To avoid a malfunction, connect the wires to the correct phase terminals (U, V, and W) of the servo amplifier and servo motor.
- Connect the servo amplifier power output (U, V, and W) to the servo motor power input (U, V, and W) directly. Do not let a magnetic contactor, etc. intervene. Otherwise, it may cause a malfunction.

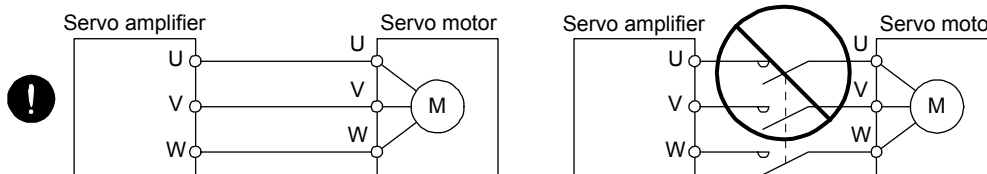

- The connection diagrams in this instruction manual are shown for sink interfaces, unless stated otherwise.
- The surge absorbing diode installed to the DC relay for control output should be fitted in the specified direction. Otherwise, the emergency stop and other protective circuits may not operate.

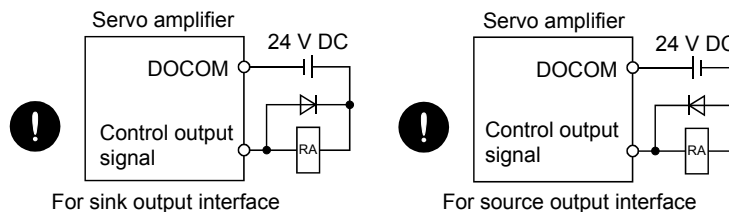

- When the cable is not tightened enough to the terminal block, the cable or terminal block may generate heat because of the poor contact. Be sure to tighten the cable with specified torque.
- Connecting a servo motor for different axis to the U, V, W, or CN2 may cause a malfunction.

(3) Test run and adjustment

⚠ CAUTION

- Before operation, check the parameter settings. Improper settings may cause some machines to perform unexpected operation.
- Never adjust or change the parameter values extremely as it will make operation unstable.
- Do not close to moving parts at servo-on status.

(4) Usage

⚠ CAUTION

- Provide an external emergency stop circuit to ensure that operation can be stopped and power switched off immediately.
- Do not disassemble, repair, or modify the equipment.
- Before resetting an alarm, make sure that the run signal of the servo amplifier is off in order to prevent a sudden restart. Otherwise, it may cause an accident.

⚠ CAUTION

- Use a noise filter, etc. to minimize the influence of electromagnetic interference. Electromagnetic interference may be given to the electronic equipment used near the servo amplifier.
- Burning or breaking a servo amplifier may cause a toxic gas. Do not burn or break it.
- Use the servo amplifier with the specified servo motor.
- The electromagnetic brake on the servo motor is designed to hold the motor shaft and should not be used for ordinary braking.
- For such reasons as service life and mechanical structure (e.g. where a ball screw and the servo motor are coupled via a timing belt), the electromagnetic brake may not hold the motor shaft. To ensure safety, install a stopper on the machine side.

(5) Corrective actions

⚠ CAUTION

- When it is assumed that a hazardous condition may occur due to a power failure or product malfunction, use a servo motor with an electromagnetic brake or external brake to prevent the condition.
- Configure an electromagnetic brake circuit so that it is activated also by an external Emergency stop switch.

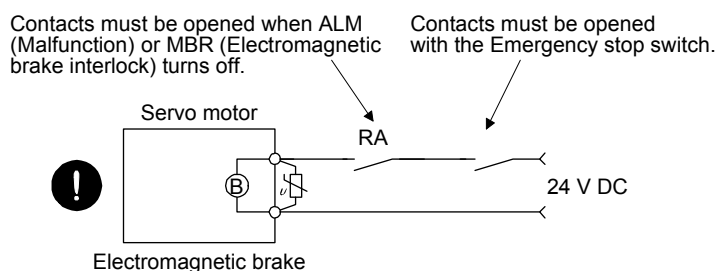

- When any alarm has occurred, eliminate its cause, ensure safety, and deactivate the alarm before restarting operation.
- Provide an adequate protection to prevent unexpected restart after an instantaneous power failure.

(6) Maintenance, inspection and parts replacement

⚠ CAUTION

- With age, the electrolytic capacitor of the servo amplifier will deteriorate. To prevent a secondary accident due to a malfunction, it is recommended that the electrolytic capacitor be replaced every 10 years when it is used in general environment. Please contact your local sales office.
- When using a servo amplifier whose power has not been turned on for a long time, contact your local sales office.

(7) General instruction

- To illustrate details, the equipment in the diagrams of this Instruction Manual may have been drawn without covers and safety guards. When the equipment is operated, the covers and safety guards must be installed as specified. Operation must be performed in accordance with this Specifications and Instruction Manual.

● DISPOSAL OF WASTE ●

Please dispose a servo amplifier, battery (primary battery) and other options according to your local laws and regulations.



EEP-ROM life

The number of write times to the EEPROM, which stores parameter settings, etc., is limited to 100,000. If the total number of the following operations exceeds 100,000, the servo amplifier may malfunction when the EEPROM reaches the end of its useful life.

- Write to the EEPROM due to parameter setting changes
- Write to the EEPROM due to device changes

STO function of the servo amplifier

When using the STO function of the servo amplifier, refer to chapter 13 of "MR-J4-_GF_(-RJ) Servo Amplifier Instruction Manual (Motion Mode)".

For the MR-J3-D05 safety logic unit, refer to app. 5 of "MR-J4-_GF_(-RJ) Servo Amplifier Instruction Manual (Motion Mode)".

Compliance with global standards

For the compliance with global standards, refer to app. 4 of "MR-J4-_GF_(-RJ) Servo Amplifier Instruction Manual (Motion Mode)".

«About the manual»

You must have this Instruction Manual and the following manuals to use this servo. Ensure to prepare them to use the servo safely.

Relevant manuals

Manual name	Manual No.
MELSERVO MR-J4-_GF_(-RJ) Servo Amplifier Instruction Manual (Motion Mode)	SH(NA)030218
MELSERVO-J4 MR-J4 Servo Amplifier Instruction Manual (Troubleshooting)	SH(NA)030109
MELSERVO Servo Motor Instruction Manual (Vol. 3) (Note 1)	SH(NA)030113
MELSERVO Linear Servo Motor Instruction Manual (Note 2)	SH(NA)030110
MELSERVO Direct Drive Motor Instruction Manual (Note 3)	SH(NA)030112
MELSERVO Linear Encoder Instruction Manual (Note 2, 4)	SH(NA)030111
EMC Installation Guidelines	IB(NA)67310

- Note
1. It is necessary for using a rotary servo motor.
 2. It is necessary for using a linear servo motor.
 3. It is necessary for using a direct drive motor.
 4. It is necessary for using a fully closed loop system.

This Instruction Manual does not describe the following items. The followings are the same as "MR-J4-_GF_(-RJ) Servo Amplifier Instruction Manual (Motion Mode)". For details of the items, refer to each chapter/section of the detailed explanation field. "MR-J4-_GF_" means "MELSERVO MR-J4-_GF_(-RJ) Servo Amplifier Instruction Manual (Motion Mode)".

Item	Detailed explanation
Installation	MR-J4-_GF_ Chapter 2
Signals and wiring	MR-J4-_GF_ Chapter 3
Normal gain adjustment	MR-J4-_GF_ Chapter 6
Special adjustment functions	MR-J4-_GF_ Chapter 7
Outline drawings	MR-J4-_GF_ Chapter 9
Characteristics	MR-J4-_GF_ Chapter 10
Options and auxiliary equipment	MR-J4-_GF_ Chapter 11
Absolute position detection system	MR-J4-_GF_ Chapter 12
Using STO Function	MR-J4-_GF_ Chapter 13
Using a Linear servo motor	MR-J4-_GF_ Chapter 14
Using a direct drive motor	MR-J4-_GF_ Chapter 15
Fully closed loop system	MR-J4-_GF_ Chapter 16
Application of functions	MR-J4-_GF_ Chapter 17

«U.S. customary units»

U.S. customary units are not shown in this manual. Convert the values if necessary according to the following table.

Quantity	SI (metric) unit	U.S. customary unit
Mass	1 [kg]	2.2046 [lb]
Length	1 [mm]	0.03937 [inch]
Torque	1 [N·m]	141.6 [oz·inch]
Moment of inertia	1 [(× 10 ⁻⁴ kg·m ²)]	5.4675 [oz·inch ²]
Load (thrust load/axial load)	1 [N]	0.2248 [lbf]
Temperature	N [°C] × 9/5 + 32	N [°F]

CONTENTS

1. FUNCTIONS AND CONFIGURATION	1- 1 to 1- 8
1.1 For proper use of the I/O mode	1- 1
1.2 I/O mode specification list.....	1- 2
1.3 Function list.....	1- 4
1.4 Configuration including peripheral equipment.....	1- 7
2. POINT TABLE OPERATION	2- 1 to 2-90
2.1 Link device	2- 1
2.1.1 Profile	2- 1
2.1.2 Detailed explanation of the RYn/RXn profile.....	2- 4
2.1.3 Detailed explanation of the RWwn/RWrn profile.....	2- 7
2.1.4 Code.....	2- 9
2.1.5 Data communication timing chart.....	2-20
2.1.6 Remote register-based position/speed setting	2-23
2.2 Switching power on for the first time.....	2-26
2.3 Automatic operation mode.....	2-28
2.3.1 Automatic operation mode	2-28
2.3.2 Automatic operation using point table.....	2-29
2.4 Manual operation mode	2-57
2.4.1 JOG operation.....	2-57
2.5 Home position return mode	2-61
2.5.1 Outline of home position return.....	2-62
2.5.2 Method -5 (Home position ignorance (Servo-on position as home position))	2-68
2.5.3 Automatic positioning to home position function.....	2-69
2.6 Point table setting method	2-70
2.6.1 Setting procedure.....	2-70
2.6.2 Detailed setting window	2-72
2.6.3 Single-step feed	2-73
2.7 Programming example by function	2-74
2.7.1 System configuration example.....	2-74
2.7.2 Reading the servo amplifier status.....	2-77
2.7.3 Writing an operation command.....	2-78
2.7.4 Reading data	2-80
2.7.5 Writing data	2-82
2.7.6 Operation.....	2-85
2.8 Program example for continuous operation.....	2-88
3. PARAMETERS	3- 1 to 3-24
3.1 Parameter list.....	3- 1
3.1.1 Basic setting parameters ([Pr. PA_ _]).....	3- 2
3.1.2 Gain/filter setting parameters ([Pr. PB_ _]).....	3- 3
3.1.3 Extension setting parameters ([Pr. PC_ _])	3- 4
3.1.4 I/O setting parameters ([Pr. PD_ _])	3- 7
3.1.5 Extension setting 2 parameters ([Pr. PE_ _]).....	3- 8
3.1.6 Extension setting 3 parameters ([Pr. PF_ _]).....	3- 9
3.1.7 Linear servo motor/DD motor setting parameters ([Pr. PL_ _]).....	3-11

3.1.8 Positioning control parameters ([Pr. PT_ _])	3-12
3.1.9 Network setting parameters ([Pr. PN_ _])	3-14
3.2 Detailed list of parameters	3-15
3.2.1 Basic setting parameters ([Pr. PA_ _])	3-15
3.2.2 I/O setting parameters ([Pr. PD_ _])	3-15
3.2.3 Positioning control parameters ([Pr. PT_ _])	3-16
3.2.4 Network setting parameters ([Pr. PN_ _])	3-20
3.3 How to set the electronic gear	3-21
3.3.1 Electronic gear settings in the point table method and program method	3-21
3.4 Stop method for RY (n + 1) 0 (Upper stroke limit) off or RY (n + 1) 1 (Lower stroke limit) off	3-23
3.5 Stop method at software limit detection	3-24

4. TROUBLESHOOTING	4- 1 to 4-16
--------------------	--------------

4.1 Explanation for the lists	4- 1
4.2 Alarm list	4- 2
4.3 Warning list	4-12
4.4 Troubleshooting at power on	4-15

1. FUNCTIONS AND CONFIGURATION

1. FUNCTIONS AND CONFIGURATION

The items shown in the following table are the same as those for the motion mode. For details, refer to each section indicated in the detailed explanation field. "MR-J4-_GF_" means "MR-J4-_GF_(-RJ) Servo Amplifier Instruction Manual (Motion Mode)".

Item	Detailed explanation
Function block diagram	MR-J4-_GF_ section 1.2
Combinations of servo amplifiers and servo motors	MR-J4-_GF_ section 1.4
Model designation	MR-J4-_GF_ section 1.6
Structure (parts identification)	MR-J4-_GF_ section 1.7
Configuration including peripheral equipment	MR-J4-_GF_ section 1.8

1.1 For proper use of the I/O mode

(1) Servo amplifier/MR Configurator2

The I/O mode is available with the servo amplifier and MR Configurator2 with the following software versions.

Product name	Model	Software version
Servo amplifier	MR-J4-_GF_(-RJ)	A1 or later
MR Configurator2	SW1DNC-MRC2_	1.52E or later

(2) Parameter setting

Set [Pr. PN03 Station-specific mode setting] to "1" to select the I/O mode as the station-specific mode.

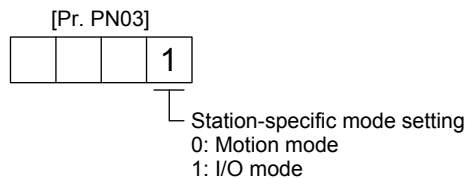

1. FUNCTIONS AND CONFIGURATION

1.2 I/O mode specification list

Only the specifications of the I/O mode are listed here. For other specifications, refer to section 1.3 of "MR-J4-_GF_(-RJ) Servo Amplifier Instruction Manual (Motion Mode)".

Item		Description		
Servo amplifier model		MR-J4-_GF_(-RJ)		
Command method	Point table	Operational specifications	Positioning with specification of point table No. (255 points)	
		Position command input (Note 1)	Absolute value command method	Set in the point table. Setting range of feed length per point: -999999 to 999999 [$\times 10^{\text{STM}}$ μm], -99.9999 to 99.9999 [$\times 10^{\text{STM}}$ inch], -999999 to 999999 [pulse]
			Incremental value command method	Set in the point table. Setting range of feed length per point: 0 to 999999 [$\times 10^{\text{STM}}$ μm], 0 to 99.9999 [$\times 10^{\text{STM}}$ inch], 0 to 999999 [pulse]
		Speed command input	Set the acceleration/deceleration time constants in the point table. Set the S-pattern acceleration/deceleration time constants with [Pr. PT51].	
		System	Signed absolute value command method/incremental value command method	
	Torque limit	Set with a parameter or link device.		
	Position command data input	Operational specifications	Positioning with a setting of a remote register	
		Position command input	Set the position command data with a remote register. Setting range of feed length: -999999 to 999999 [$\times 10^{\text{STM}}$ μm], -99.9999 to 99.9999 [$\times 10^{\text{STM}}$ inch], -999999 to 999999 [pulse]	
		Speed command input	Select from point tables with a remote register. Set the speed command data (speed) with a remote register. Set the S-pattern acceleration/deceleration time constants with [Pr. PT51].	
		System	Signed absolute position command method, incremental value command method	
Operation mode	Automatic operation mode	Point table	Each positioning operation Point table No. input method/position data input method Operates each positioning based on position command and speed command.	
		Automatic continuous positioning operation	Varying-speed operation (2 to 255 speeds)/automatic continuous positioning operation (2 to 255 points)/ Automatic continuous operation to a point table selected at startup/automatic continuous operation to the point table No. 1	
	Manual operation mode	Point table	JOG operation Executes a contact input or an inching operation with the CC-Link IE Field Network communication function based on speed command set with parameters.	
Home position return mode	Point table	Dog type (Rear end detection, Z-phase reference)	For details of the home position return types, refer to section 2.5.	
		Stopper type (Stopper position reference)		
		Count type (Front end detection, Z-phase reference)		
		Dog type (Rear end detection, rear end reference)		
		Count type (Front end detection, front end reference)		
		Dog cradle type		
		Dog type last Z-phase reference (Note 2)		
		Dog type front end reference		

1. FUNCTIONS AND CONFIGURATION

Item		Description
Home position return mode	Point table	Dogless Z-phase reference (Note 2)
		Home position ignorance (servo-on position as home position)
		Homing on positive home switch and index pulse (method 3)
		Homing on positive home switch and index pulse (method 4)
		Homing on negative home switch and index pulse (method 5)
		Homing on negative home switch and index pulse (method 6)
		Homing on home switch and index pulse (method 7)
		Homing on home switch and index pulse (method 8)
		Homing on home switch and index pulse (method 11)
		Homing on home switch and index pulse (method 12)
		Homing without index pulse (method 19)
		Homing without index pulse (method 20)
		Homing without index pulse (method 21)
		Homing without index pulse (method 22)
		Homing without index pulse (method 23)
		Homing without index pulse (method 24)
		Homing without index pulse (method 27)
		Homing without index pulse (method 28)
		Homing on index pulse (method 33)
		Homing on index pulse (method 34)
Homing on current position (method 35)		
Homing on current position (method 37)		
Automatic positioning to home position function	High-speed automatic positioning to a defined home position	
Other functions	Absolute position detection/external limit switch/software stroke limit	

For details of the home position return types, refer to section 2.5.

- Note
1. STM is the ratio to the setting value of the position data. STM can be changed with [Pr. PT03 Feeding function selection].
 2. If a direct drive motor or incremental type linear encoder is used, the dog type last Z-phase reference home position return or dogless Z-phase reference home position return cannot be used.

1. FUNCTIONS AND CONFIGURATION

1.3 Function list

POINT
<p>● The symbol in the control mode column means as follows: CP: Point table method</p>

The following table lists the functions of this servo. For details of the functions, refer to each section indicated in the detailed explanation field. "MR-J4-_GF_" means "MR-J4-_GF_(-RJ) Servo Amplifier Instruction Manual (Motion Mode)".

Function	Description	Control mode		Detailed explanation
		CP		
Model adaptive control	This function achieves a high response and stable control following the ideal model. The two-degrees-of-freedom model adaptive control enables you to set a response to the command and response to the disturbance separately. Additionally, this function can be disabled. To disable this function, refer to section 7.5 of "MR-J4-_GF_(-RJ) Servo Amplifier Instruction Manual (Motion Mode)".	○	○	/
Point table method	Set 1 to 255 point tables in advance, and select any point table to perform operation in accordance with the set values. To select point tables, use external input signals or communication function.	○	○	Chapter 2
Roll feed display function (available in the future)	Positions based on specified travel distance from a status display "0" of current/command positions at start.	○	○	/
Home position return	For the home position return types, refer to section 2.5.	○	○	Section 2.5
High-resolution encoder	Rotary servo motors compatible with the MELSERVO-J4 series are equipped with a high-resolution encoder of 4194304 pulses/rev.	○	○	/
Absolute position detection system	Home position return is required only once, and not required at every power-on.	○	○	MR-J4-_GF_ chapter 12
Gain switching function	You can switch gains during rotation/stop, and can use input devices to switch gains during operation.	○	○	MR-J4-_GF_ section 7.2
Advanced vibration suppression control II	This function suppresses vibration at an arm end or residual vibration.	○	○	MR-J4-_GF_ section 7.1.5
Machine resonance suppression filter	This filter function (notch filter) decreases the gain of the specific frequency to suppress the resonance of the mechanical system.	○	○	MR-J4-_GF_ section 7.1.1
Shaft resonance suppression filter	When a load is mounted to the servo motor shaft, resonance by shaft torsion during driving may generate a mechanical vibration at high frequency. The shaft resonance suppression filter suppresses the vibration.	○	○	MR-J4-_GF_ section 7.1.3
Adaptive filter II	The servo amplifier detects mechanical resonance and sets filter characteristics automatically to suppress mechanical vibration.	○	○	MR-J4-_GF_ section 7.1.2
Low-pass filter	Suppresses high-frequency resonance which occurs as the servo system response is increased.	○	○	MR-J4-_GF_ section 7.1.4
Machine analyzer function	Analyzes the frequency characteristic of the mechanical system by simply connecting an MR Configurator2 installed personal computer and the servo amplifier. MR Configurator2 is necessary for this function.	○	○	/
Robust filter	For roll feed axis, etc. of which a response level cannot be increased because of the large load to motor inertia ratio, this function improves a disturbance response.	○	○	[Pr. PE41]
Slight vibration suppression control	Suppresses vibration of ±1 pulse generated at a servo motor stop.	○	○	[Pr. PB24]
Electronic gear	Position commands can be multiplied by 1/864 to 33935.	○	○	[Pr. PA06] [Pr. PA07]

1. FUNCTIONS AND CONFIGURATION

Function	Description	Control mode		Detailed explanation
		CP		
Auto tuning	Automatically adjusts the gain to optimum value if load applied to the servo motor shaft varies.	<input type="radio"/>		MR-J4-_GF_ section 6.3
Brake unit	Used when the regenerative option cannot provide enough regenerative power. Can be used for the 5 kW or more servo amplifier.	<input type="radio"/>		MR-J4-_GF_ section 11.3
Power regeneration converter	Used when the regenerative option cannot provide enough regenerative power. Can be used for the 5 kW or more servo amplifier.	<input type="radio"/>		MR-J4-_GF_ section 11.4
Regenerative option	Use a regenerative option when the built-in regenerative resistor of the servo amplifier does not have sufficient regenerative capacity for a large regenerative power generated.	<input type="radio"/>		MR-J4-_GF_ section 11.2
Alarm history clear	Clears alarm histories.	<input type="radio"/>		[Pr. PC21]
Input signal selection (device settings)	The input devices including PC (proportional control) can be assigned to certain pins of the CN3 connector.	<input type="radio"/>		[Pr. PD03] to [Pr. PD05]
Output signal selection (device settings)	The output devices including MBR (electromagnetic brake interlock) can be assigned to certain pins of the CN3 connector.	<input type="radio"/>		[Pr. PD07] to [Pr. PD09]
Output signal (DO) forced output	Turns on/off the output signals forcibly independently of the servo status. Use this function for checking output signal wiring, etc.	<input type="radio"/>		MR-J4-_GF_ section 4.5.1 (1) (d)
Torque limit	Limits the servo motor torque.	<input type="radio"/>		[Pr. PA11] [Pr. PA12]
Test operation mode	Jog operation/positioning operation/motor-less operation/DO forced output/program operation/single-step feed Note that MR Configurator2 is necessary for positioning operation, program operation, and single-step feed.	<input type="radio"/>		Section 2.6.3 MR-J4-_GF_ section 4.5
Analog monitor output	Outputs servo status with voltage in real time.	<input type="radio"/>		[Pr. PC09] [Pr. PC10]
MR Configurator2	Using a personal computer, you can perform the parameter setting, test operation, monitoring, and others.	<input type="radio"/>		MR-J4-_GF_ section 11.7
Linear servo system	Linear servo systems can be configured using a linear servo motor and linear encoder.	<input type="radio"/>		MR-J4-_GF_ chapter 14
Direct drive servo system	Direct drive servo systems can be configured to drive a direct drive motor.	<input type="radio"/>		MR-J4-_GF_ chapter 15
Fully closed loop system	Fully closed loop system can be configured using the load-side encoder.	<input type="radio"/>		MR-J4-_GF_ chapter 16
One-touch tuning	Adjusts gains just by pressing buttons on the servo amplifier or by clicking a button on MR Configurator2.	<input type="radio"/>		MR-J4-_GF_ section 6.2
SEMI-F47 function	This servo amplifier complies with the SEMI-F47 standard. Thus, even when an instantaneous power failure occurs during operation, the electrical energy charged in the capacitor is used and [AL. 10 Undervoltage] is not triggered.	<input type="radio"/>		MR-J4-_GF_ section 7.4 [Pr. PA20] [Pr. PF25]
Tough drive function	This function makes the equipment continue operating even under the condition that an alarm occurs. The tough drive function includes two types: the vibration tough drive and the instantaneous power failure tough drive.	<input type="radio"/>		MR-J4-_GF_ section 7.3
Drive recorder function	This function continuously monitors the servo status and records the status transition before and after an alarm for a fixed period of time. You can check the recorded data on the drive recorder window on MR Configurator2 by clicking the "Graph" button. However, the drive recorder is not available when: 1. The graph function of MR Configurator2 is being used. 2. The machine analyzer function is being used. 3. [Pr. PF21] is set to "-1". 4. The controller is not connected (except the test operation mode). 5. An alarm related to the controller is occurring.	<input type="radio"/>		[Pr. PA23]

1. FUNCTIONS AND CONFIGURATION

Function	Description	Control mode		Detailed explanation
		CP		
STO function	This amplifier complies with the STO function as functional safety of IEC/EN 61800-5-2. You can create a safety system for the equipment easily.	<input type="radio"/>		MR-J4-_GF_ chapter 13
Servo amplifier life diagnosis function	You can check the cumulative energization time and the number of on/off times of the inrush relay. This function gives an indication of the replacement time for parts of the servo amplifier including a capacitor and a relay before they malfunction. MR Configurator2 is necessary for this function.	<input type="radio"/>		
Power monitoring function	This function calculates the power running energy and the regenerative power from the data in the servo amplifier such as speed and current. Power consumption and others are displayed on MR Configurator2.	<input type="radio"/>		
Machine diagnosis function	From the data in the servo amplifier, this function estimates the friction and vibrational component of the drive system in the equipment and recognizes an error in the machine parts, including a ball screw and bearing. MR Configurator2 is necessary for this function.	<input type="radio"/>		
Limit switch	External limit switches can be used to limit travel intervals of the servo motor.	<input type="radio"/>		
S-pattern acceleration/deceleration	Enables smooth acceleration and deceleration. Set S-pattern acceleration/deceleration time constants with [Pr. PT51]. As compared with linear acceleration/deceleration, the acceleration/deceleration time will be longer for the S-pattern acceleration/deceleration time constants regardless of command speed.	<input type="radio"/>		[Pr. PT51]
Software limit	Limits travel intervals by address using parameters. Enables the same function with the limit switch by setting parameters.	<input type="radio"/>		MR-J4-_GF_ section 5.3
Speed limit	The servo motor speed can be limited.	<input type="radio"/>		[Pr. PT67]
Lost motion compensation function	This function improves the response delay generated when the machine moving direction is reversed.	<input type="radio"/>		MR-J4-_GF_ section 7.6
Super trace control	This function sets constant and uniform acceleration/deceleration droop pulses to almost 0.	<input type="radio"/>		MR-J4-_GF_ section 7.7
SLMP	SLMP (SeamLess Message Protocol) is a protocol to access SLMP-compatible devices from external devices (such as a personal computer and an HMI) or CPU module via Ethernet. The parameters of servo amplifiers can be set (read or written) and monitored.	<input type="radio"/>		
Functional safety unit (available in the future)	MR-D30 can be used to expand the safety observation function.	<input type="radio"/>		

1. FUNCTIONS AND CONFIGURATION

1.4 Configuration including peripheral equipment

CAUTION

- Connecting a servo motor of the wrong axis to U, V, W, or CN2 of the servo amplifier may cause a malfunction.
- The CN1A and CN1B connectors are dedicated for CC-Link IE Field Network. Do not connect a network other than CC-Link IE Field Network. Otherwise, a malfunction may occur.

POINT

- Equipment other than the servo amplifier and servo motor are optional or recommended products.

The following illustration is an example of MR-J4-20GF-RJ.

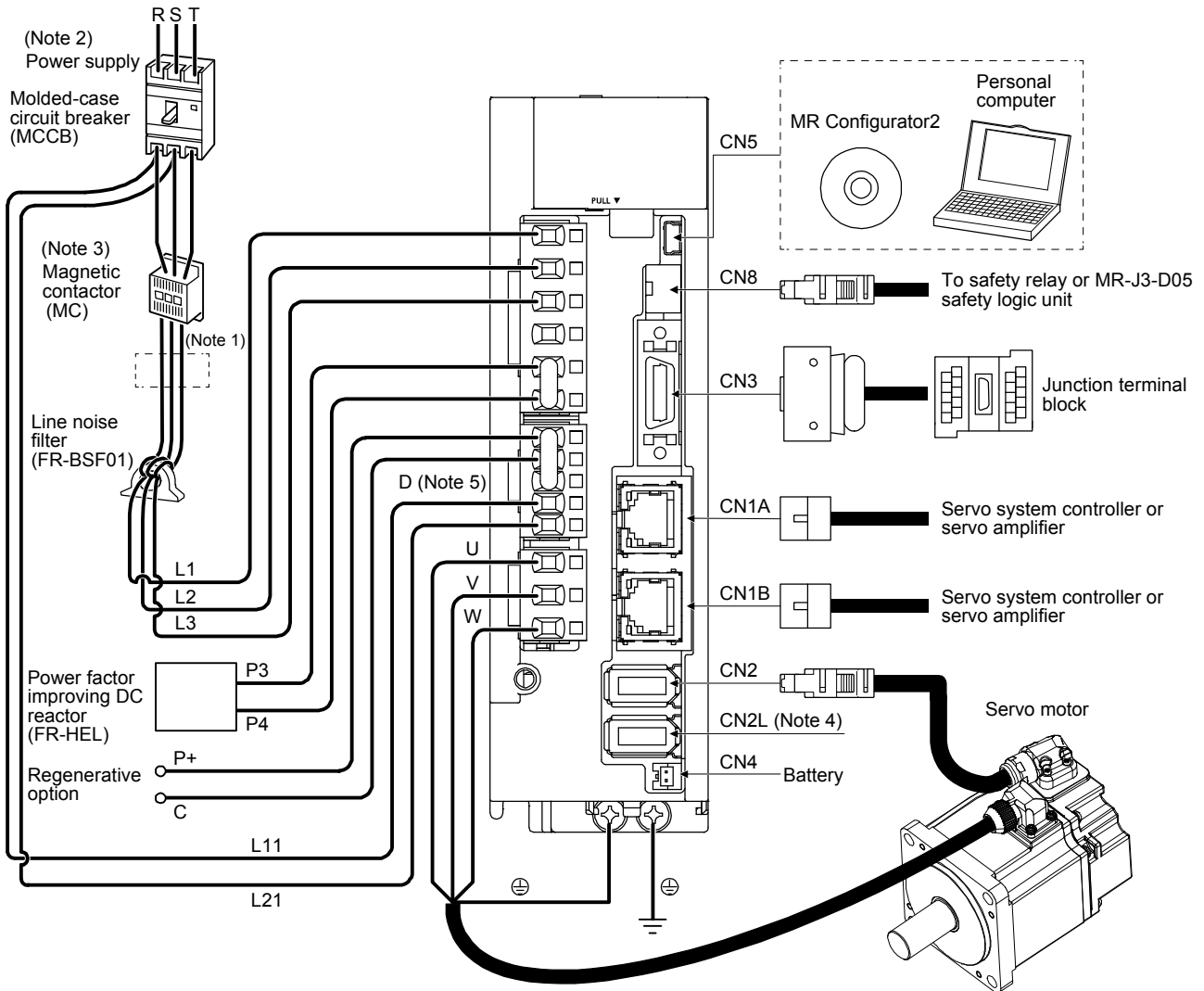

1. FUNCTIONS AND CONFIGURATION

- Note
1. The power factor improving AC reactor can also be used. In this case, the power factor improving DC reactor cannot be used. When not using the power factor improving DC reactor, short P3 and P4.
 2. For 1-phase 200 V AC to 240 V AC, connect the power supply to L1 and L3. Leave L2 open. Refer to section 1.3 of "MR-J4-_GF_(-RJ) Servo Amplifier Instruction Manual (Motion Mode)" for the power supply specifications.
 3. Depending on the main circuit voltage and operation pattern, bus voltage decreases, and that may cause the forced stop deceleration to shift to the dynamic brake deceleration. When dynamic brake deceleration is not required, slow the time to turn off the magnetic contactor.
 4. This is for MR-J4-_GF_-RJ servo amplifier. MR-J4-_GF_ servo amplifier does not have CN2L connector. When using MR-J4-_GF_-RJ servo amplifier in the linear servo system or in the fully closed loop system, connect an external encoder to this connector. Refer to table 1.1 of "MR-J4-_GF_(-RJ) Servo Amplifier Instruction Manual (Motion Mode)" and "Linear Encoder Instruction Manual" for the connectible external encoders.
 5. Always connect between P+ and D terminals. When using a regenerative option, refer to section 11.2 of "MR-J4-_GF_(-RJ) Servo Amplifier Instruction Manual (Motion Mode)".

2. POINT TABLE OPERATION

2. POINT TABLE OPERATION

The items shown in the following table are the same as those for the motion mode. For details, refer to each section indicated in the detailed explanation field. "MR-J4-_GF_" means "MR-J4-_GF_(-RJ) Servo Amplifier Instruction Manual (Motion Mode)".

Item	Detailed explanation
Startup	MR-J4-_GF_ Section 4.2
Switch setting and display of the servo amplifier	MR-J4-_GF_ Section 4.3
Test operation	MR-J4-_GF_ Section 4.4
Test operation mode	MR-J4-_GF_ Section 4.5

POINT
●When you use a linear servo motor, replace the following left words to the right words. Load to motor inertia ratio → Load to motor mass ratio Torque → Thrust

2.1 Link device

2.1.1 Profile

Input signals (input devices) and output signals (output devices) can be used together with CC-Link IE Field Network communication and external input/output signals of the CN3 connector. Select input signals to assign with [Pr. PD03] to [Pr. PD05] and output signals to assign with [Pr. PD07] to [Pr. PD09].
When turning off input/output signals, turn off both CC-Link IE Field Network communication and external I/O signals of the CN3 connector. The following shows the profile of link devices communicated with the master station in cyclic transmission.

2. POINT TABLE OPERATION

Table 2.1 RYn/RXn profile

Master station → Servo amplifier (RYn)				Servo amplifier → Master station (RXn)			
(Note) Device No.	Device	Symbol	CN3 connector pin No.	(Note) Device No.	Device	Symbol	CN3 connector pin No.
RYn0	Servo-on	SON		RXn0	Ready	RD	
RYn1	Forward rotation start	ST1		RXn1	In-position	INP	9
RYn2	Reverse rotation start	ST2		RXn2	Rough match	CP0	
RYn3	Proximity dog	DOG	19	RXn3	Not used		
RYn4	Not used			RXn4	Limiting torque	TLC	
RYn5				RXn5	Not used		
RYn6	Automatic/manual selection	MD0		RXn6	Electromagnetic brake interlock	MBR	13
RYn7	Temporary stop/restart	TSTP		RXn7	During a temporary stop	PUS	
RYn8	Monitor output execution demand	MOR		RXn8	Monitoring	MOF	
RYn9	Instruction code execution demand	COR		RXn9	Instruction code execution completion	COF	
RYnA to RYnF	Not used			RXnA	Warning	WNG	
RY (n + 1) 0	Upper stroke limit	FLS		RXnB	Battery warning	BWNG	
RY (n + 1) 1	Lower stroke limit	RLS		RXnC	Travel completion	MEND	
RY (n + 1) 2	Operation alarm reset	ORST		RXnD	Dynamic brake interlock	DB	
RY (n + 1) 3 to RY (n + 1) F	Not used			RXnE	Position range output	POT	
RY (n + 2) 0	Position command execution demand	PSR		RXnF	Not used		
RY (n + 2) 1	Speed command execution demand	SPR		RX (n + 1) 0	Home position return completion 2	ZP2	
RY (n + 2) 2 to RY (n + 2) 6	Not used			RX (n + 1) 1 to RX (n + 1) F	Not used		
RY (n + 2) 7	Proportional control	PC		RX (n + 2) 0	Position command execution completion	PSF	
RY (n + 2) 8	Gain switching	CDP		RX (n + 2) 1	Speed command execution completion	SPF	
RY (n + 2) 9	Not used			RX (n + 2) 2 to RX (n + 2) F	Not used		
RY (n + 2) A	Position/speed specifying method selection	CSL		RX (n + 3) 0 to RX (n + 3) 9	Not used		
RY (n + 2) B	Absolute value/incremental value selection	CAOR		RX (n + 3) A	Malfunction	ALM	15
RY (n + 2) C to RY (n + 2) F	Not used			RX (n + 3) B	Remote station communication ready	CRD	
RY (n + 3) 0 to RY (n + 3) 9	Not used			RX (n + 3) C to RX (n + 3) F	Not used		
RY (n + 3) A	Reset	RES					
RY (n + 3) B to RY (n + 3) F	Not used						

Note. "n" depends on the station No. setting.

2. POINT TABLE OPERATION

Table 2.2 RWwn/RWrn profile

Master station → Servo amplifier (RWwn)		Servo amplifier → Master station (RWrn)	
(Note) Device No.	Device	(Note) Device No.	Device
RWwn0	Monitor 1	RWrn0	Monitor 1 data - Lower 16 bits
RWwn1	Not used	RWrn1	Monitor 1 data - Upper 16 bits
RWwn2	Monitor 2	RWrn2	Monitor 2 data - Lower 16 bits
RWwn3	Not used	RWrn3	Monitor 2 data - Upper 16 bits
RWwn4	Instruction code - Lower 16 bits	RWrn4	Respond code
RWwn5	Instruction code - Upper 16 bits	RWrn5	Not used
RWwn6	Point table No. selection	RWrn6	Point table No. output
RWwn7	Not used	RWrn7	Not used
RWwn8	Position command data - Lower 16 bits/Point table No.	RWrn8	
RWwn9	Position command data - Upper 16 bits	RWrn9	
RWwnA	Speed command data - Lower 16 bits/Point table No.	RWrnA	
RWwnB	Speed command data - Upper 16 bits	RWrnB	
RWwnC	Writing data - Lower 16 bits	RWrnC	Reading data - Lower 16 bits
RWwnD	Writing data - Upper 16 bits	RWrnD	Reading data - Upper 16 bits
RWwnE	Not used	RWrnE	Not used
RWwnF		RWrnF	

Note. "n" depends on the station No. setting.

2. POINT TABLE OPERATION

2.1.2 Detailed explanation of the RYn/RXn profile

(1) RYn profile

Device No.	Device	Description						
RYn0	Servo-on	Turn on RYn0 to power on the base circuit, and make the servo amplifier ready to operate. (servo-on status) Turn it off to shut off the base circuit, and coast the servo motor.						
RYn1	Forward rotation start	<p>1. Absolute value command method Turning on RYn1 during automatic operation will execute one positioning based on the position data set in the point tables. Turning on RYn1 during home position return will also start home position return. Turning on RYn1 during JOG operation will rotate the servo motor in the forward rotation direction while it is on. The forward rotation means address increasing direction.</p> <p>2. Incremental value command method Turning on RYn1 during automatic operation will execute one positioning in the forward rotation direction based on the position data set in point tables. Turning on RYn1 during home position return will also start home position return. Turning on RYn1 during JOG operation will rotate the servo motor in the forward rotation direction while it is on. The forward rotation means address increasing direction. Turning on both RYn1 and RYn2 during JOG operation will stop the servo motor.</p>						
RYn2	Reverse rotation start	Use this device with the incremental value command method. Turning on RYn2 during automatic operation will execute one positioning in the reverse rotation direction based on the position data set in point tables. Turning on RYn2 during JOG operation will rotate the servo motor in the reverse rotation direction while it is on. The reverse rotation means address decreasing direction. Turning on RYn2 during home position return will execute automatic positioning to the home position. Turning on both RYn1 and RYn2 during JOG operation will stop the servo motor.						
RYn3	Proximity dog	When RYn3 is turned off, a proximity dog will be detected. The polarity for dog can be changed with [Pr. PT29]. <table border="1" data-bbox="635 1227 1093 1379"> <tr> <td>[Pr. PT29]</td> <td>Polarity for proximity dog detection</td> </tr> <tr> <td>___0 (initial value)</td> <td>Detection with off</td> </tr> <tr> <td>___1</td> <td>Detection with on</td> </tr> </table>	[Pr. PT29]	Polarity for proximity dog detection	___0 (initial value)	Detection with off	___1	Detection with on
[Pr. PT29]	Polarity for proximity dog detection							
___0 (initial value)	Detection with off							
___1	Detection with on							
RYn6	Automatic/manual selection	Turning on RYn6 sets automatic operation mode, and turning it off sets manual operation mode.						
RYn7	Temporary stop/restart	Turning on RYn7 will temporarily stop the servo motor. Turning on RYn7 again will restart. However, if RYn7 is turned on during home position return, turning on RYn7 again does not restart the home position return operation. Turning on RYn1 (Forward rotation start)/RYn2 (Reverse rotation start) during a temporary stop will not rotate the servo motor. Changing the automatic operation mode to manual operation mode during a temporary stop will erase a travel remaining distance.						
RYn8	Monitor output execution demand	Turning on RYn8 sets the following data. At this time, RXn8 turns on. While RYn8 is on, the monitor value is always updated. RWrn0: Lower 16 bits of data requested with RWwn0 (Monitor 1) RWrn1: Upper 16 bits of data requested with RWwn0 (Monitor 1) RWrn2: Lower 16 bits of data requested with RWwn2 (Monitor 2) RWrn3: Upper 16 bits of data requested with RWwn2 (Monitor 2) RWrn4: Respond code indicating a normal or error result						
RYn9	Instruction code execution demand	Turning on RYn9 executes the processing corresponding to the instruction code set with RWwn4 and RWwn5. After executing the instruction code is completed, a respond code indicating a normal or error result is stored in RWrn4, and RXn9 turns on. Refer to section 2.1.4 (2) for details of instruction codes.						

2. POINT TABLE OPERATION

Device No.	Device	Description
RY (n + 1) 0	Upper stroke limit	To start the operation, turn on RY (n + 1) 0 and RY (n + 1) 1. Turning off the device corresponding to the servo motor rotation direction will bring the servo motor to a slow stop and make it servo-locked. The stop method can be changed with [Pr. PD12]. The home position is not erased; however, home position return may be required in some cases. Refer to [Pr. PD12] and section 3.4 for details.
RY (n + 1) 1	Lower stroke limit	
RY (n + 2) 0	Position command execution demand	Turning on RY (n + 2) 0 sets the point table No. or position command data set in RWwn8 and RWwn9. If a point table No. or position command data is set to the servo amplifier, a respond code indicating a normal or error result is set in RWn4 and RX (n + 2) 0 (Position instruction execution completion) turns on. Refer to section 2.1.6 for details.
RY (n + 2) 1	Speed command execution demand	Turning on RY (n + 2) 1 sets the point table No. or speed command data set in RWwnA and RWwnB. If a point table No. or speed command data is set to the servo amplifier, a respond code indicating a normal or error result is set in RWn4 and RX (n + 2) 1 (Position instruction execution completion) turns on. Refer to section 2.1.6 for details.
RY (n + 2) 7	Proportional control	Turn on RY (n + 2) 7 to switch the speed amplifier from the proportional integral type to the proportional type. If the servo motor at a stop is rotated even one pulse due to any external factor, it generates torque to compensate for a position shift. When the servo motor shaft is to be locked mechanically after RXnC (Travel completion) is turned off, switching on RY (n + 2) 7 (Proportional control) upon turning RXnC (Travel completion) off will suppress the unnecessary torque generated to compensate for a position shift. When the shaft is to be locked for a long time, turn on RY (n + 2) 7 (Proportional control) and make the torque less than the rated torque with the torque limit.
RY (n + 2) 8	Gain switching	Turn on RY (n + 2) 8 to use the values of [Pr. PB29] to [Pr. PB36] and [Pr. PB56] to [Pr. PB60] as the load to motor inertia ratio and gain values.
RY (n + 2) A	Position/speed specifying method selection	Select how to give a position command and speed command. Off: Specify a point table No. with RWwn6 (Point table No. selection) to give a position command and speed command. On: Set position command data and speed command data in RWwn8 to RWwnB to give a position command and speed command. To turn on RY (n + 2) A, set "___2" in [Pr. PT62].
RY (n + 2) B	Absolute value/incremental value selection	Select the command method of position data with RY (n + 2) B. RY (n + 2) B is enabled when the position/speed specifying method using remote registers is selected with RY (n + 2) A (Position/speed specifying method selection) and the absolute value command method is selected with [Pr. PT01]. Off: Position data is used as an absolute value. On: Position data is used as an incremental value.
RY (n + 3) A	Reset	Turn on RY (n + 3) A to reset alarms. However, some alarms cannot be cleared with RY (n + 3) A.

(2) RXn profile

Device No.	Device	Description
RXn0	Ready	When the servo-on is on and the servo amplifier is ready to operate, RXn0 turns on.
RXn1	In-position	When the number of droop pulses is in the preset in-position range, RXn1 turns on. The in-position range can be changed with [Pr. PA10]. When the in-position range is increased, INP may be always on during low-speed rotation.
RXn2	Rough match	When a command remaining distance is lower than the rough match output range set with [Pr. PT12], RXn2 turns on. This is not outputted during base circuit shut-off.
RXn4	Limiting torque	RXn4 turns on when a generated torque reaches a value set with [Pr. PA11 Forward rotation torque limit] or [Pr. PA12 Reverse rotation torque limit].
RXn6	Electromagnetic brake interlock	When using the device, set operation delay time of the electromagnetic brake in [Pr. PC02]. When a servo-off status or alarm occurs, RXn6 turns off.
RXn7	During a temporary stop	When a deceleration begins for a stop, RXn7 turns on by RYn7 (Temporary stop/restart). When RYn7 (Temporary stop/restart) is enabled again and an operation is restarted, RXn7 turns off.
RXn8	Monitoring	Refer to RYn8 (Monitor output execution demand).
RXn9	Instruction code execution completion	Refer to RYn9 (Instruction code execution demand).

2. POINT TABLE OPERATION

Device No.	Device	Description
RXnA	Warning	When a warning occurs, RXnA turns on. When a warning is not occurring, turning on the power will turn off RXnA after 4 s to 5 s.
RXnB	Battery warning	RXnB turns on when [AL. 92 Battery cable disconnection warning] or [AL. 9F Battery warning] has occurred. When the battery warning is not occurring, turning on the power will turn off RXnB after 4 s to 5 s.
RXnC	Travel completion	When the droop pulses are within the in-position output range set with [Pr. PA10] and the command remaining distance is "0", RXnC turns on. When turning on RYn0 (servo-on), RXnC turns on at the same time.
RXnD	Dynamic brake interlock	RXnD turns off when the dynamic brake needs to operate.
RXnE	Position range output	When an actual current position is within the range set with [Pr. PT19] to [Pr. PT22], RXnE turns on. This will be off when a home position return is not completed or base circuit shut-off is in progress.
RX (n + 1) 0	Home position return completion 2	When a home position return completes normally, RX (n + 1) 0 turns on. RX (n + 1) 0 is always on unless the home position is erased. In the incremental system, it turns off with one of the following conditions. 1) [AL. 69 Command error] occurs. 2) Home position return is not being executed. 3) Home position return is in progress. If a home position return completes once in the absolute position detection system, RX (n + 1) 0 is always on. However, it will be off with one of the conditions 1) to 3) or the following conditions 4) to 8). 4) The home position return is not performed after [AL. 25 Absolute position erased] and [AL. E3 Absolute position counter warning] occurred. 5) The home position return is not performed after the electronic gear ([Pr. PA06] and [Pr. PA07]) was changed. 6) The home position return is not performed after the setting of [Pr. PA03 Absolute position detection system selection] was changed from "Disabled" to "Enabled". 7) [Pr. PA14 Rotation direction selection/travel direction selection] was changed. 8) [Pr. PA01 Operation mode] was changed.
RX (n + 2) 0	Position command execution completion	Refer to RY (n + 2) 0 (Position command execution demand).
RX (n + 2) 1	Speed command execution completion	Refer to RY (n + 2) 1 (Speed command execution demand).
RX (n + 3) A	Malfunction	When an alarm occurs, RX (n + 3) A will turn on. When an alarm is not occurring, turning on the power will turn off RX (n + 3) A after 4 s to 5 s.
RX (n + 3) B	Remote station communication ready	Turning on the power turns on RX (n + 3) B. When an alarm occurs, RX (n + 3) B will turn off.

2. POINT TABLE OPERATION

2.1.3 Detailed explanation of the RWwn/RWrn profile

(1) RWwn profile

Device No.	Device	Description	Setting range
RWwn0	Monitor 1	Setting a monitor code to monitor in RWwn0 and turning on RYn8 store data in RWrn0 and RWrn1. At this time, RXn8 turns on. Refer to section 2.1.4 (1) for monitor codes for status display.	Refer to section 2.1.4 (1).
RWwn2	Monitor 2	Setting a monitor code to monitor in RWwn2 and turning on RYn8 store data in RWrn2 and RWrn3. At this time, RXn8 turns on. Refer to section 2.1.4 (1) for monitor codes for status display.	Refer to section 2.1.4 (1).
RWwn4	Instruction code - Lower 16 bits	Set an instruction code No. used to read or write a parameter or point table data or to refer to an alarm. Setting an instruction code No. in RWwn4 and turning on RYn9 execute the instruction. RXn9 turns on after executing the instruction is completed. Refer to section 2.1.4 (2) for the instruction code No.	Refer to section 2.1.4 (2).
RWwn5	Instruction code - Upper 16 bits	When a value other than "0000h" is set in this device, the instruction code is not executed even if RYn9 is turned on and "_ _ 1 _" is set in Respond code.	0000h
RWwn6	Point table No. selection	Set a point table No. to execute in the automatic operation mode. To select the home position return mode, set "0" in RWwn6. Even if a value out of the setting range is set, an alarm or warning does not occur. However, the set value is invalid and the previous setting value is used.	0 to 255
RWwn8	Point table No./Position command data - Lower 16 bits	This function can be used while RY (n + 2) A (Position/speed specifying method selection) is on (the remote register-based position/speed specifying method is selected). (1) For the point table No. setting Setting a point table No. in RWwn8 and turning on RY (n + 2) 0 set the point table No. in the servo amplifier. After the setting is completed, RX (n + 2) 0 turns on. (2) For the position command data setting/point table No. (speed command) setting or for the position command data setting/speed command data setting Setting the lower 16 bits in RWwn8 and upper 16 bits in RWwn9 and turning on RY (n + 2) 0 write both the upper and lower 16 bits of the position command data. After the writing is completed, RX (n + 2) 0 turns on. Use [Pr. PT62] to select whether to set a point table No. or position command data. Refer to section 2.1.6 for details of the point table No. or position command data.	Point table No.: 1 to 255 Absolute value command: Position command data -999999 to 999999 Incremental value command: Position command data 0 to 999999
RWwn9	Position command data - Upper 16 bits		

2. POINT TABLE OPERATION

Device No.	Device	Description	Setting range
RWwnA	Point table No./Speed command data - Lower 16 bits	<p>This function can be used while RY (n + 2) A (Position/speed specifying method selection) is on (the remote register-based position/speed specifying method is selected).</p> <p>(1) For the point table No. setting or for the position command data setting/point table No. (speed command) setting Setting a point table No. in RWwnA and turning on RY (n + 2) 1 set the point table No. in the servo amplifier. After the setting is completed, RX (n + 2) 1 turns on.</p> <p>(2) For the position command data setting/speed command data setting Setting the lower 16 bits in RWwnA and upper 16 bits in RWwnB and turning on RY (n + 2) 1 write both the upper and lower 16 bits of the speed command data. After the writing is completed, RX (n + 2) 1 turns on.</p> <p>Use [Pr. PT62] to select whether to set a point table No. or speed command data.</p> <p>Refer to section 2.1.6 for details of the point table No. or speed command data.</p> <p>When setting a servo motor speed in this remote register, always set an acceleration time constant and deceleration time constant in the point table No. 1.</p>	Point table No.: 1 to 255 Speed command data: 0 to permissible speed
RWwnB	Speed command data - Upper 16 bits		
RWwnC	Writing data - Lower 16 bits	<p>Set writing data used to write a parameter or point table data or to clear the alarm history.</p> <p>Setting writing data in RWwnC and RWwnD and turning on RYn9 write the data to the servo amplifier. When the writing is completed, RXn9 turns on.</p> <p>Refer to section 2.1.4 (2) (b) for writing data.</p>	Refer to section 2.1.4 (2) (b).
RWwnD	Writing data - Upper 16 bits		

(2) RWrn profile

Device No.	Device	Description	Setting range
RWrn0	Monitor 1 data - Lower 16 bits	The lower 16 bits of the data corresponding to the monitor code set in RWwn0 is stored.	
RWrn1	Monitor 1 data - Upper 16 bits	The upper 16 bits of the data corresponding to the monitor code set in RWwn0 is stored. A sign is set if no data is set in the upper 16 bits.	
RWrn2	Monitor 2 data - Lower 16 bits	The lower 16 bits of the data corresponding to the monitor code set in RWwn2 is stored.	
RWrn3	Monitor 2 data - Upper 16 bits	The upper 16 bits of the data corresponding to the monitor code set in RWwn2 is stored. A sign is set if no data is set in the upper 16 bits.	
RWrn4	Respond code	When the codes set in RWwn0 to RWwnD have been executed normally, "0000" is set.	
RWrn6	Point table No. output	<p>The point table No. is set when RXnC (Travel completion) turns on.</p> <p>In the following condition, "0" is set in RWrn6.</p> <ul style="list-style-type: none"> • Power on • Servo-off • During home position return • Home position return completion <p>RWrn6 will keep a previous condition in the following conditions.</p> <ul style="list-style-type: none"> • At operation mode change • When an operation mode was switched by turning RYn6 (Automatic/manual selection) off to on or on to off. • During manual operation • Automatic positioning to home position is in progress. 	
RWrnC	Reading data - Lower 16 bits	Data corresponding to the reading code set in RWwn4 is set.	
RWrnD	Reading data - Upper 16 bits		

2. POINT TABLE OPERATION

2.1.4 Code

(1) Monitor code

Use any of the instruction codes 0100h to 011Fh to read the decimal point position (multiplying factor) of the status display.

Setting any code No. that is not given in this section sets an error code (_ _ _ 1) in Respond code (RWrn4). At this time, "0000" is set in RWrn0 to RWrn3.

Code No.	Monitored item	Answer data (Servo amplifier → Master station)	
		Data length	Unit
0000h			
0001h	Current position	32 bits	10 ^{STM} [μm]/10 ^(STM-4) [inch]/[pulse] (Note)
0002h			
0003h	Command position	32 bits	10 ^{STM} [μm]/10 ^(STM-4) [inch]/[pulse] (Note)
0004h			
0005h	Command remaining distance	32 bits	10 ^{STM} [μm]/10 ^(STM-4) [inch]/[pulse] (Note)
0006h			
0007h			
0008h	Point table No.	16 bits	
0009h			
000Ah	Cumulative feedback pulses	32 bits	[pulse]
000Bh			
000Ch			
000Dh			
000Eh	Droop pulses	32 bits	[pulse]
000Fh			
0010h			
0011h	Regenerative load ratio	16 bits	[%]
0012h	Effective load ratio	16 bits	[%]
0013h	Peak load ratio	16 bits	[%]
0014h	Instantaneous torque	16 bits	[%]
0015h	ABS counter	16 bits	[rev]
0016h	Servo motor speed	32 bits	0.01 [r/min]/0.01 [mm/s]
0017h			
0018h	Bus voltage	16 bits	[V]
0019h	ABS position - Lower 32 bits	32 bits	[pulse]
001Ah			
001Bh	ABS position - Upper 32 bits	32 bits	[pulse]
001Ch	Position within one-revolution	32 bits	[pulse]
001Dh			
001Eh			
001Fh			

Note. The unit can be changed to 10^{STM} [μm], 10^(STM-4) [inch], or [pulse] with the setting of [Pr. PT01].

2. POINT TABLE OPERATION

(2) Instruction code

Refer to section 2.1.5 (2) for the timing charts of the instruction codes.

(a) Reading instruction code

The data requested to be read with the instruction codes 0000h to 0AFFh is stored in reading data (RWrnC and RWrnD).

Set the instruction code No. corresponding to the item in RWwn4 and RWwn5. The instruction code No. and answer data are all hexadecimal.

Setting any instruction code No. which is not given in this section stores an error code (_ _ 1 _) in respond code (RWrn4). If any unusable parameter or point table is read, an error code (_ _ 2 _) is stored. At this time, "0000" is stored in reading data (RWrnC and RWrnD).

2. POINT TABLE OPERATION

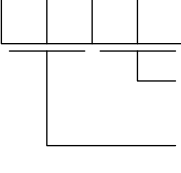
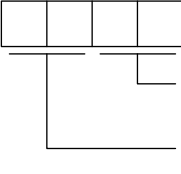
Code No.		Item/function	Reading data content (Servo amplifier → Master station)	
RWwn5	RWwn4		RWrnC	RWrdD
0000h	0000h	Operation mode Reads the current operation mode.	0000: CC-Link IE operation mode 0001: Test operation mode	Always 0
0000h	0002h	Travel distance multiplying factor Reads the multiplying factor of the position data in the point table set with [Pr. PT03].	0000: × 1 0100: × 10 0200: × 100 0300: × 1000	Always 0
0000h	0010h	Current alarm (warning) reading Reads the alarm No. or warning No. that is currently occurring.		Always 0
0000h	0020h	Alarm number in alarm history (latest alarm)		Always 0
0000h	0021h	Alarm number in alarm history (one alarm ago)		
0000h	0022h	Alarm number in alarm history (two alarms ago)		
0000h	0023h	Alarm number in alarm history (three alarms ago)		
0000h	0024h	Alarm number in alarm history (four alarms ago)		
0000h	0025h	Alarm number in alarm history (five alarms ago)		
0000h	0026h	Alarm number in alarm history (six alarms ago)		
0000h	0027h	Alarm number in alarm history (seven alarms ago)		
0000h	0028h	Alarm number in alarm history (eight alarms ago)		
0000h	0029h	Alarm number in alarm history (nine alarms ago)		
0000h	002Ah	Alarm number in alarm history (ten alarms ago)		
0000h	002Bh	Alarm number in alarm history (eleven alarms ago)		
0000h	002Ch	Alarm number in alarm history (twelve alarms ago)		
0000h	002Dh	Alarm number in alarm history (thirteen alarms ago)		
0000h	002Eh	Alarm number in alarm history (fourteen alarms ago)		
0000h	002Fh	Alarm number in alarm history (fifteen alarms ago)		

2. POINT TABLE OPERATION

Code No.		Item/function	Reading data content (Servo amplifier → Master station)	
RWwn5	RWwn4		RWrnC	RWrnD
0000h	0030h	Alarm occurrence time in alarm history (latest alarm)	Returns the occurrence time of the alarm that occurred before.	Always 0
0000h	0031h	Alarm occurrence time in alarm history (one alarm ago)		
0000h	0032h	Alarm occurrence time in alarm history (two alarms ago)		
0000h	0033h	Alarm occurrence time in alarm history (three alarms ago)		
0000h	0034h	Alarm occurrence time in alarm history (four alarms ago)		
0000h	0035h	Alarm occurrence time in alarm history (five alarms ago)		
0000h	0036h	Alarm occurrence time in alarm history (six alarms ago)		
0000h	0037h	Alarm occurrence time in alarm history (seven alarms ago)		
0000h	0038h	Alarm occurrence time in alarm history (eight alarms ago)		
0000h	0039h	Alarm occurrence time in alarm history (nine alarms ago)		
0000h	003Ah	Alarm occurrence time in alarm history (ten alarms ago)		
0000h	003Bh	Alarm occurrence time in alarm history (eleven alarms ago)		
0000h	003Ch	Alarm occurrence time in alarm history (twelve alarms ago)		
0000h	003Dh	Alarm occurrence time in alarm history (thirteen alarms ago)		
0000h	003Eh	Alarm occurrence time in alarm history (fourteen alarms ago)		
0000h	003Fh	Alarm occurrence time in alarm history (fifteen alarms ago)		
0000h	0040h	Input device status 0 Reads the status (OFF/ON) of input devices.	Bit 0 to bit F indicate the OFF/ON status of the corresponding input devices.	Always 0

Bit	Device	Bit	Device
0	Servo-on	8	Monitor output execution demand
1	Forward rotation start	9	Instruction code execution demand
2	Reverse rotation start	A	
3	Proximity dog	B	
4		C	
5		D	
6	Automatic/manual selection	E	
7	Temporary stop/restart	F	

2. POINT TABLE OPERATION

Code No.		Item/function	Reading data content (Servo amplifier → Master station)																																					
RWwn5	RWwn4		RWrnC	RWrnD																																				
0000h	0041h	Input device status 1 Reads the status (OFF/ON) of input devices.	Bit 0 to bit F indicate the OFF/ON status of the corresponding input devices.	Always 0																																				
			<table border="1"> <thead> <tr> <th>Bit</th> <th>Device</th> <th>Bit</th> <th>Device</th> </tr> </thead> <tbody> <tr> <td>0</td> <td>Upper stroke limit</td> <td>8</td> <td></td> </tr> <tr> <td>1</td> <td>Lower stroke limit</td> <td>9</td> <td></td> </tr> <tr> <td>2</td> <td></td> <td>A</td> <td></td> </tr> <tr> <td>3</td> <td></td> <td>B</td> <td></td> </tr> <tr> <td>4</td> <td></td> <td>C</td> <td></td> </tr> <tr> <td>5</td> <td></td> <td>D</td> <td></td> </tr> <tr> <td>6</td> <td></td> <td>E</td> <td></td> </tr> <tr> <td>7</td> <td></td> <td>F</td> <td></td> </tr> </tbody> </table>	Bit	Device	Bit	Device	0	Upper stroke limit	8		1	Lower stroke limit	9		2		A		3		B		4		C		5		D		6		E		7		F		
Bit	Device	Bit	Device																																					
0	Upper stroke limit	8																																						
1	Lower stroke limit	9																																						
2		A																																						
3		B																																						
4		C																																						
5		D																																						
6		E																																						
7		F																																						
0000h	0042h	Input device status 2 Reads the status (OFF/ON) of input devices.	Bit 0 to bit F indicate the OFF/ON status of the corresponding input devices.	Always 0																																				
			<table border="1"> <thead> <tr> <th>Bit</th> <th>Device</th> <th>Bit</th> <th>Device</th> </tr> </thead> <tbody> <tr> <td>0</td> <td>Position command execution demand</td> <td>8</td> <td>Gain switching</td> </tr> <tr> <td>1</td> <td>Speed command execution demand</td> <td>9</td> <td></td> </tr> <tr> <td>2</td> <td></td> <td>A</td> <td>Position/speed specifying method selection</td> </tr> <tr> <td>3</td> <td></td> <td>B</td> <td>Absolute value/incremental value selection</td> </tr> <tr> <td>4</td> <td></td> <td>C</td> <td></td> </tr> <tr> <td>5</td> <td></td> <td>D</td> <td></td> </tr> <tr> <td>6</td> <td>Internal torque limit selection</td> <td>E</td> <td></td> </tr> <tr> <td>7</td> <td>Proportional control</td> <td>F</td> <td></td> </tr> </tbody> </table>	Bit	Device	Bit	Device	0	Position command execution demand	8	Gain switching	1	Speed command execution demand	9		2		A	Position/speed specifying method selection	3		B	Absolute value/incremental value selection	4		C		5		D		6	Internal torque limit selection	E		7	Proportional control	F		
Bit	Device	Bit	Device																																					
0	Position command execution demand	8	Gain switching																																					
1	Speed command execution demand	9																																						
2		A	Position/speed specifying method selection																																					
3		B	Absolute value/incremental value selection																																					
4		C																																						
5		D																																						
6	Internal torque limit selection	E																																						
7	Proportional control	F																																						
0000h	0043h	Input device status 3 Reads the status (OFF/ON) of input devices.	Bit 0 to bit F indicate the OFF/ON status of the corresponding input devices.	Always 0																																				
			<table border="1"> <thead> <tr> <th>Bit</th> <th>Device</th> <th>Bit</th> <th>Device</th> </tr> </thead> <tbody> <tr> <td>0</td> <td></td> <td>8</td> <td></td> </tr> <tr> <td>1</td> <td></td> <td>9</td> <td></td> </tr> <tr> <td>2</td> <td></td> <td>A</td> <td>Reset</td> </tr> <tr> <td>3</td> <td></td> <td>B</td> <td></td> </tr> <tr> <td>4</td> <td></td> <td>C</td> <td></td> </tr> <tr> <td>5</td> <td></td> <td>D</td> <td></td> </tr> <tr> <td>6</td> <td></td> <td>E</td> <td></td> </tr> <tr> <td>7</td> <td></td> <td>F</td> <td></td> </tr> </tbody> </table>	Bit	Device	Bit	Device	0		8		1		9		2		A	Reset	3		B		4		C		5		D		6		E		7		F		
Bit	Device	Bit	Device																																					
0		8																																						
1		9																																						
2		A	Reset																																					
3		B																																						
4		C																																						
5		D																																						
6		E																																						
7		F																																						
0000h	0081h	Energization time Reads the energization time since shipment.	Returns the energization time [h].	Always 0																																				
0000h	0082h	Power on frequency Reads the number of power-on times since shipment.	Returns the number of power-on times.	Always 0																																				
0000h	00A0h	Load to motor inertia ratio Reads the estimated load to motor inertia ratio on the servo motor shaft.	Return unit [0.1 times] Returns the estimated load to motor inertia ratio.	Always 0																																				

2. POINT TABLE OPERATION

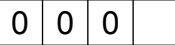
Code No.		Item/function	Reading data content (Servo amplifier → Master station)	
RWwn5	RWwn4		RWrnC	RWrnD
0000h	00B0h	Home position within one-revolution (CYC0) Reads the cycle counter value of an absolute home position.	Return unit [pulse] Stores the lower 16 bits of the cycle counter value of the absolute home position (32-bit data).	Stores the upper 16 bits of the cycle counter value of the absolute home position.
0000h	00B2h	Home position multi-revolution data (ABS0) Reads the multi-revolution counter value of an absolute home position.	Return unit [rev] Returns the multi-revolution counter value.	Always 0
0000h	00C0h	Error parameter No./Point data No. reading Reads the parameter No. and point table No. that have an error.	 <ul style="list-style-type: none"> Parameter No. or point table No. Parameter group <ul style="list-style-type: none"> 0: Basic setting parameters (Pr. PA__) 1: Gain/filter setting parameters (Pr. PB__) 2: Extension setting parameters (Pr. PC__) 3: I/O setting parameters (Pr. PD__) 4: Extension setting 2 parameters (Pr. PE__) 5: Extension setting 3 parameters (Pr. PF__) 6 to A: For manufacturer setting parameters (Pr. PL__) B: Linear/DD motor setting parameters (Pr. PL__) C: Extension setting parameters for specific modes (Pr. PT__) E: Network setting parameters (Pr. PN__) Type <ul style="list-style-type: none"> 1: Parameter 2: Point table 	Always 0
0000h	0100h to 011Fh	Monitor multiplying factor Reads the multiplying factor of data to be read with a monitor code. The instruction codes 0100h to 011Fh correspond to each of the monitor codes 0000h to 001Fh. To the instruction code that has no corresponding monitor code, 0000h is applied.	0000: × 1 0001: × 10 0002: × 100 0003: × 1000	Always 0
0000h	0200h	Parameter group reading Reads the parameter group written with the code No. 8200h.	 <ul style="list-style-type: none"> Parameter group <ul style="list-style-type: none"> 0: Basic setting parameters (Pr. PA__) 1: Gain/filter setting parameters (Pr. PB__) 2: Extension setting parameters (Pr. PC__) 3: I/O setting parameters (Pr. PD__) 4: Extension setting 2 parameters (Pr. PE__) 5: Extension setting 3 parameters (Pr. PF__) 6 to A: For manufacturer setting parameters (Pr. PL__) B: Linear/DD motor setting parameters (Pr. PL__) C: Extension setting parameters for specific modes (Pr. PT__) E: Network setting parameters (Pr. PN__) 	Always 0

2. POINT TABLE OPERATION

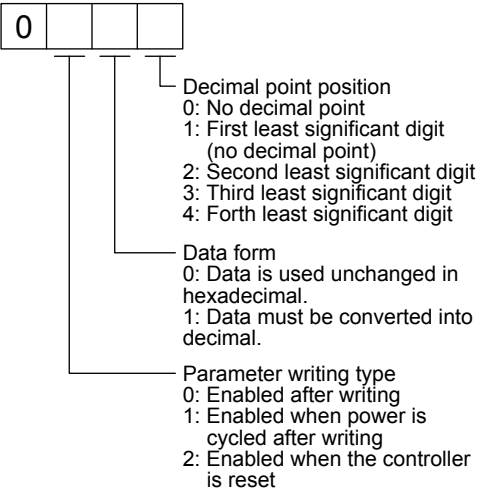
Code No.		Item/function	Reading data content (Servo amplifier → Master station)	
RWwn5	RWwn4		RWrnC	RWrnD
0000h	0201h to 02FFh	Parameter data reading Reads the setting values of the parameters in the group read with the code No. 0200h. The lower two digits of the code No. which are converted to decimal correspond to the parameter No.	Stores the lower 16 bits of the setting value of the requested parameter No.	Stores the upper 16 bits of the setting value of the requested parameter No.
0000h	0301h to 03FFh	Data form of parameter Reads the data form of the setting values of the parameters in the group read with the code No. 0200h. The lower two digits of the code No. which are converted to decimal correspond to the parameter No.	Stores the data form of the requested parameter No. 	Always 0
0000h	0401h to 04FFh	Position data of point table No. 1 to 255 Reads the position data of point table No. 1 to 255.	Stores the lower 16 bits of the position data of the requested point table No.	Stores the upper 16 bits of the position data of the requested point table No.
0000h	0601h to 06FFh	Servo motor speed of point table No. 1 to 255 The lower two digits of the code No. which are converted to decimal correspond to the point table No.	Stores the lower 16 bits of the servo motor speed of the requested point table No.	Stores the upper 16 bits of the servo motor speed of the requested point table No.
0000h	0701h to 07FFh	Acceleration time constant of point table No. 1 to 255 The lower two digits of the code No. which are converted to decimal correspond to the point table No.	Stores the acceleration time constant of the requested point table No.	Always 0
0000h	0801h to 08FFh	Deceleration time constant of point table No. 1 to 255 The lower two digits of the code No. which are converted to decimal correspond to the point table No.	Stores the deceleration time constant of the requested point table No.	Always 0
0000h	0901h to 09FFh	Dwell of point table No. 1 to 255 The lower two digits of the code No. which are converted to decimal correspond to the point table No.	Stores the dwell of the requested point table No.	Always 0
0000h	0A01h to 0AFFh	Sub function of point table No. 1 to 255 The lower two digits of the code No. which are converted to decimal correspond to the point table No.	Stores the sub functions of the requested point table No.	Always 0

2. POINT TABLE OPERATION

(b) Writing instruction code

Data requested to be written with the instruction codes 8000h to 91FFh is written to the servo amplifier.

Set the instruction code No. corresponding to the item in instruction code (RWwn4 and RWwn5) and the data to be written in writing data (RWwnC and RWwnD). The instruction code No. and answer data are all hexadecimal.

Setting any instruction code No. which is not given in this section will store an error code (_ _ 1 _) in respond code (RWrn4).

Code No.		Item	Writing data contents (Master station → Servo amplifier)					
RWwn5	RWwn4		RWwnC	RWwnD				
0000h	8010h	Alarm reset command Clears the alarm that is currently occurring.	1EA5	Do not write data.				
0000h	8101h	Feedback pulse value display data clear command Resets the display data of the status display "Cumulative feedback pulses" to "0".	1EA5	Do not write data.				
0000h	8200h	Writing command of parameter group Writes the group of the parameter to write with code No. 8201h to 82FFh and 8301h to 83FFh. Writes the group of the parameter to read with code No. 0201h to 02FFh and 0301h to 03FFh.	<table border="1" style="display: inline-table; vertical-align: middle;"> <tr> <td style="width: 20px; height: 20px; text-align: center;">0</td> <td style="width: 20px; height: 20px; text-align: center;">0</td> <td style="width: 20px; height: 20px; text-align: center;">0</td> <td style="width: 20px; height: 20px; text-align: center;"> </td> </tr> </table> Parameter group 0: Basic setting parameters (Pr. PA_ _) 1: Gain/filter setting parameters (Pr. PB_ _) 2: Extension setting parameters (Pr. PC_ _) 3: I/O setting parameters (Pr. PD_ _) 4: Extension setting 2 parameters (Pr. PE_ _) 5: Extension setting 3 parameters (Pr. PF_ _) 6 to A: For manufacturer setting B: Linear/DD motor setting parameters (Pr. PL_ _) C: Extension setting parameters for specific modes (Pr. PT_ _) E: Network setting parameters (Pr. PN_ _)	0	0	0		Do not write data.
0	0	0						
0000h	8201h to 82FFh	Data RAM command of parameter Writes the setting values of the parameters in the group written with code No. 8200h to the RAM. This setting value is cleared when the power supply is shut off. The lower two digits of the code No. which are converted to decimal correspond to the parameter No. An error code is returned if a value outside the range of a parameter is written.	Set the lower 16 bits of the parameter setting value.	Set the upper 16 bits of the parameter setting value. For 16-bit parameters, this setting is not required.				
0000h	8301h to 83FFh	Data EEP-ROM command of parameter Writes the setting values of the parameters in the group written with code No. 8200h to the EEP-ROM. The setting value written in the EEP-ROM is held even when the power supply is shut off. The lower two digits of the code No. which are converted to decimal correspond to the parameter No. An error code is returned if a value outside the range of a parameter is written.	Set the lower 16 bits of the parameter setting value.	Set the upper 16 bits of the parameter setting value. For 16-bit parameters, this setting is not required.				

2. POINT TABLE OPERATION

Code No.		Item	Writing data contents (Master station → Servo amplifier)	
RWwn5	RWwn4		RWwnC	RWwnD
0000h	8401h to 84FFh	Position data RAM command of point table Writes the position data of point table No. 1 to 255 to the RAM. This setting value is cleared when the power supply is shut off. The lower two digits of the code No. which are converted to decimal correspond to the point table No.	Set the lower 16 bits of the position data.	Set the upper 16 bits of the position data.
0000h	8601h to 86FFh	Servo motor speed data RAM command of point table Writes the servo motor speed of point table No. 1 to 255 to the RAM. This setting value is cleared when the power supply is shut off. The lower two digits of the code No. which are converted to decimal correspond to the point table No.	Set the lower 16 bits of the servo motor speed.	Set the upper 16 bits of the servo motor speed.
0000h	8701h to 87FFh	Acceleration time constant data RAM command of point table Writes the acceleration time constant of point table No. 1 to 255 to the RAM. This setting value is cleared when the power supply is shut off. The lower two digits of the code No. which are converted to decimal correspond to the point table No.	Set the acceleration time constant.	Do not write data.
0000h	8801h to 88FFh	Deceleration time constant data RAM command of point table Writes the deceleration time constant of point table No. 1 to 255 to the RAM. This setting value is cleared when the power supply is shut off. The lower two digits of the code No. which are converted to decimal correspond to the point table No.	Set the deceleration time constant.	Do not write data.
0000h	8901h to 89FFh	Dwell data RAM command of point table Writes the dwell of point table No. 1 to 255 to the RAM. This setting value is cleared when the power supply is shut off. The lower two digits of the code No. which are converted to decimal correspond to the point table No.	Set the dwell.	Do not write data.
0000h	8A01h to 8AFFh	Sub function data RAM command of point table Writes the sub functions of point table No. 1 to 255 to the RAM. This setting value is cleared when the power supply is shut off. The lower two digits of the code No. which are converted to decimal correspond to the point table No.	Set the sub function.	Do not write data.

2. POINT TABLE OPERATION

Code No.		Item	Writing data contents (Master station → Servo amplifier)	
RWwn5	RWwn4		RWwnC	RWwnD
0000h	8B01h to 8BFFh	Position data EEPROM command of point table Writes the position data of point table No. 1 to 255 to the EEPROM. The setting value written in the EEPROM is held even when the power supply is shut off. The lower two digits of the code No. which are converted to decimal correspond to the point table No.	Set the lower 16 bits of the position data.	Set the upper 16 bits of the position data.
0000h	8D01h to 8DFFh	Servo motor speed data EEPROM command of point table Writes the servo motor speed of point table No. 1 to 255 to the EEPROM. The setting value written in the EEPROM is held even when the power supply is shut off. The lower two digits of the code No. which are converted to decimal correspond to the point table No.	Set the lower 16 bits of the servo motor speed.	Set the upper 16 bits of the servo motor speed.
0000h	8E01h to 8EFFh	Acceleration time constant data EEPROM command of point table Writes the acceleration time constant of point table No. 1 to 255 to the EEPROM. The setting value written in the EEPROM is held even when the power supply is shut off. The lower two digits of the code No. which are converted to decimal correspond to the point table No.	Set the acceleration time constant.	Do not write data.
0000h	8F01h to 8FFFh	Deceleration time constant data EEPROM command of point table Writes the deceleration time constants of point table No. 1 to 255 to the EEPROM. The setting value written in the EEPROM is held even when the power supply is shut off. The lower two digits of the code No. which are converted to decimal correspond to the point table No.	Set the deceleration time constant.	Do not write data.
0000h	9001h to 90FFh	Dwell data EEPROM command of point table Writes the dwell of point table No. 1 to 255 to the EEPROM. The setting value written in the EEPROM is held even when the power supply is shut off. The lower two digits of the code No. which are converted to decimal correspond to the point table No.	Set the dwell.	Do not write data.
0000h	9101h to 91FFh	Sub function data EEPROM command of point table Writes the sub function of point table No. 1 to 255 to the EEPROM. The setting value written in the EEPROM is held even when the power supply is shut off. The lower two digits of the code No. which are converted to decimal correspond to the point table No.	Set the sub function.	Do not write data.

2. POINT TABLE OPERATION

(3) Respond code (RWrn4)

If any of monitor codes, instruction codes, point table No. selection, point table No./position command data, and point table No./speed command data set in remote registers is outside the setting range, the corresponding error code is set in respond code (RWrn4). If the setting is within the setting range, "0000" is set.

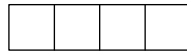

Error of the monitor code

Code No.	Error detail	Details
0	Normal result	The code has been completed normally.
1	Code error	An incorrect code No. is specified.
2		
3		

Error of the reading instruction code and writing instruction code

Code No.	Error detail	Details
0	Normal result	The instruction has been completed normally.
1	Code error	An incorrect code No. is specified.
2	Parameter selection error	A parameter No. that cannot be referred to is specified.
3	Writing data out of range	A value out of the range is set.

Error of the point table No./position command data

Code No.	Error detail	Details
0	Normal result	The instruction has been completed normally.
1		
2		
3	Writing data out of range	A value out of the range is set.

Error of the point table No./speed command data

Code No.	Error detail	Details
0	Normal result	The instruction has been completed normally.
1		
2		
3	Writing data out of range	A value out of the range is set.

2. POINT TABLE OPERATION

2.1.5 Data communication timing chart

(1) Monitor code

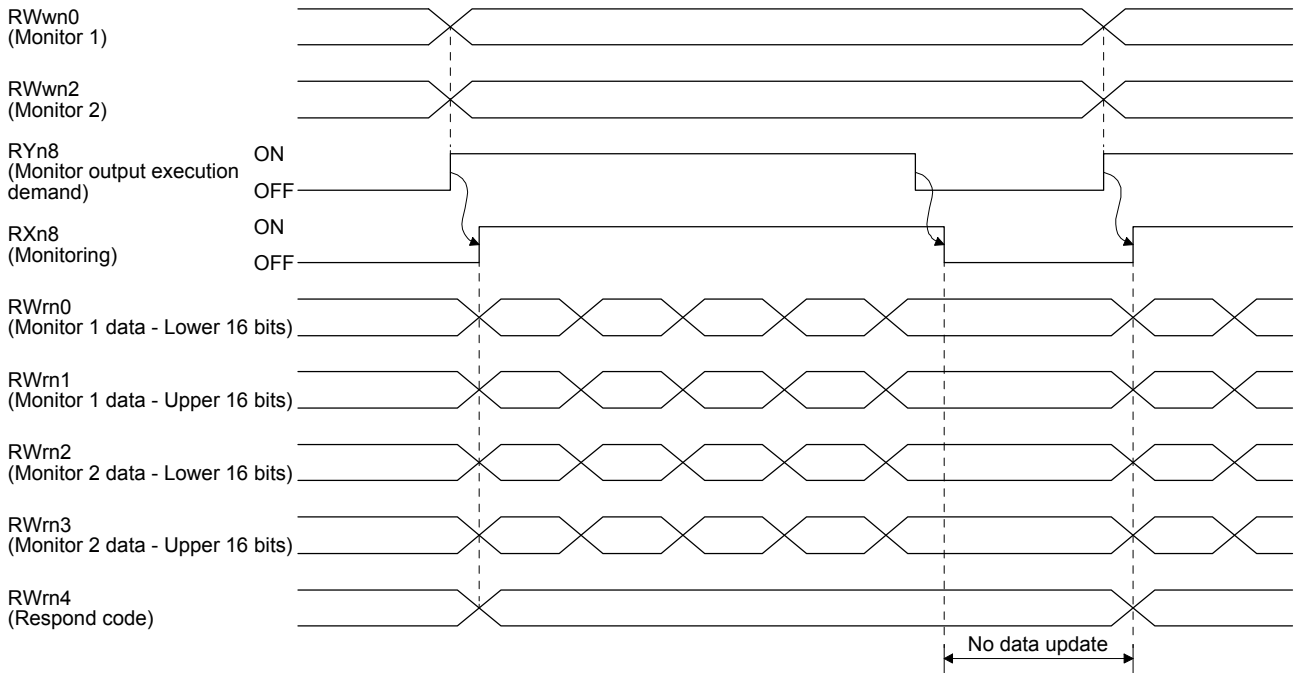

Set a monitor code (refer to section 2.1.4 (1)) in RWwn0 (Monitor 1) and RWwn2 (Monitor 2) and turn on RYn8 (Monitor output execution demand). Turning on RYn8 (Monitor output execution demand) sets the following data. All 32-bit data is set in remote registers after divided into the upper 16 bits and lower 16 bits Data is all hexadecimal. At this time, RXn8 (Monitoring) turns on.

RWrn0 (Monitor 1 data - Lower 16 bits): Lower 16 bits of data requested with RWwn0 (Monitor 1)
 RWrn1 (Monitor 1 data - Upper 16 bits): Upper 16 bits of data requested with RWwn0 (Monitor 1)
 RWrn2 (Monitor 2 data - Lower 16 bits): Lower 16 bits of data requested with RWwn2 (Monitor 2)
 RWrn3 (Monitor 2 data - Upper 16 bits): Upper 16 bits of data requested with RWwn2 (Monitor 2)

A sign is set if no data is set in RWrn1 or RWrn3. For "+", "0000" is set, and "FFFF" is set for "-". Monitor data RWrn0 to RWrn3 set in remote registers are constantly updated while RXn8 (Monitoring) is ON.

When RXn8 (Monitoring) turns off, the update of the monitor data RWrn0 to RWrn3 stops, and does not restart until RXn8 (Monitoring) turns on again.

If a monitor code out of the specifications is set in either RWwn0 (Monitor 1) or RWwn2 (Monitor 2), the corresponding error code (_ _ _ 1) is stored in RWrn4 (Respond code). At this time, "0000" is stored in the monitor data RWrn0 to RWrn3. Refer to section 2.1.4 (3) for details of respond code.

Until RXn8 turns on after RYn8 is turned on, do not change the setting values of RWwn0 and RWwn2.

2. POINT TABLE OPERATION

(2) Instruction code

(a) Reading instruction code (0000h to 0AFFh)

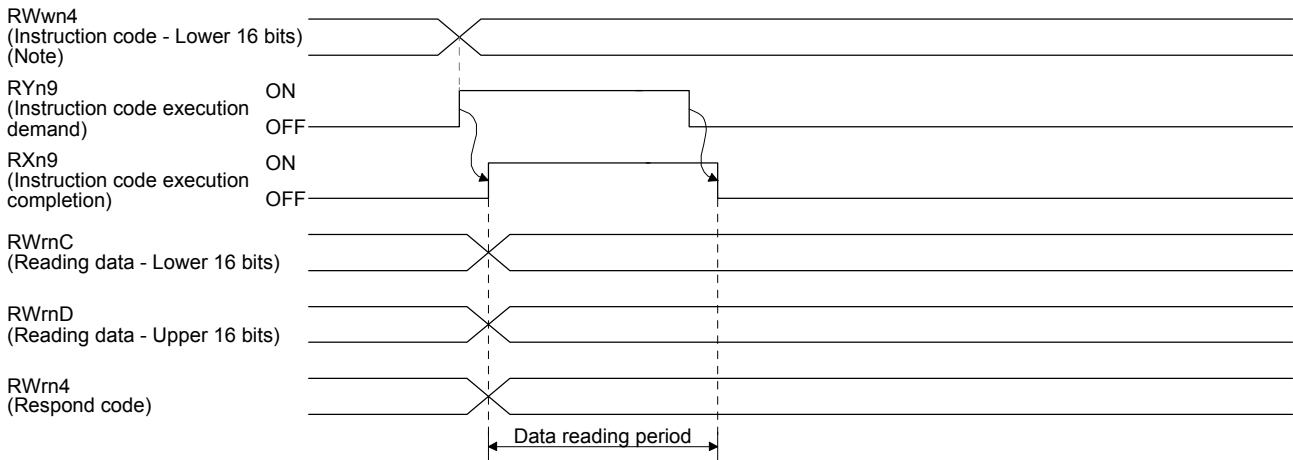

Note. The value of RWwn5 (Instruction code - Upper 16 bits) is fixed to "0".

Set a reading instruction code (refer to section 2.1.4 (2) (a)) in RWwn4 (Instruction code - Lower 16 bits) and turn on RYn9 (Instruction code execution demand). Turning on RYn9 (Instruction code execution demand) sets the data corresponding to the reading code in RWrnC (Reading data - Lower 16 bits) and RWrnD (Reading data - Upper 16 bits). Data is all hexadecimal. At this time, RXn9 (Instruction code execution completion) also turns on. Read the reading data to be set in RWrnC (Reading data - Lower 16 bits) and RWrnD (Reading data - Upper 16 bits) while RYn9 (Instruction code execution demand) is on. The data set in RWrnC (Reading data - Lower 16 bits) and RWrnD (Reading data - Upper 16 bits) is held until RYn9 (Instruction code execution demand) is turned on with the next reading instruction code set.

If the instruction code out of the specifications is set in RWwn4 (Instruction code - Lower 16 bits), an error code (_ _ 1 _) is set in respond code. If any unusable parameter or point table is read, an error code (_ _ 2 _) is set.

Turn off RYn9 (Instruction code execution demand) after the data reading is completed.

Until RXn9 turns on after RYn9 is turned on, do not change the setting value of RWwn4. Turn off RYn9 after the data reading is completed.

2. POINT TABLE OPERATION

(b) Writing instruction code (8000h to 91FFh)

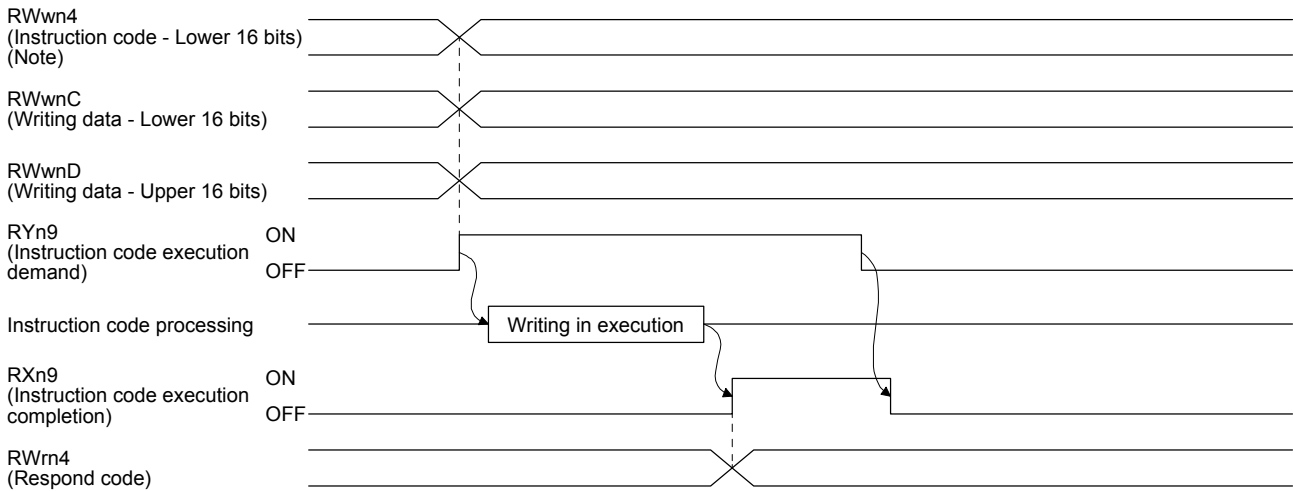

Note. The value of RWwn5 (Instruction code - Upper 16 bits) is fixed to "0".

Set a writing instruction code (refer to section 2.1.4 (2) (b)) in RWwn4 (Instruction code - Lower 16 bits) and the data to write (data to execute) in RWwnC (Writing data - Lower 16 bits) and RWwnD (Writing data - Upper 16 bits) in hexadecimal, and turn on RYn9 (Instruction code execution demand).

Turning on RYn9 (Instruction code execution demand) writes the data set with RWwnC (Writing data - Lower 16 bits) and RWwnD (Writing data - Upper 16 bits) to the item corresponding to the writing instruction code. After the writing is completed, RXn9 (Instruction code execution completion) turns on.

If the instruction code out of the specifications is set in RWwn4 (Instruction code - Lower 16 bits), an error code (_ _ 1 _) is set in respond code.

Turn off RYn9 (Instruction code execution demand) after RXn9 (Instruction code execution completion) has turned on.

Until RXn9 turns on after RYn9 is turned on, do not change the setting values of RWwn4, RWwnC, and RWwnD. Turn off RYn9 while RXn9 is on.

2. POINT TABLE OPERATION

2.1.6 Remote register-based position/speed setting

The functions in this section can be used while RY (n + 2) A (Position/speed specifying method selection) is on (the remote register-based position/speed specifying method is selected).

Turn off RY (n + 2) A to perform home position return.

The position command and speed command necessary for positioning can be selected with [Pr. PT62] as follows.

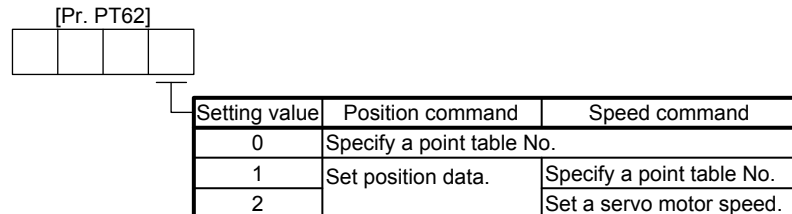

(1) For the point table No. setting

Specify the point table No. stored in the servo amplifier and execute positioning.

Before executing positioning, set "___0" (initial value) in [Pr. PT62] to enable the operation that follows the setting of the point table No.

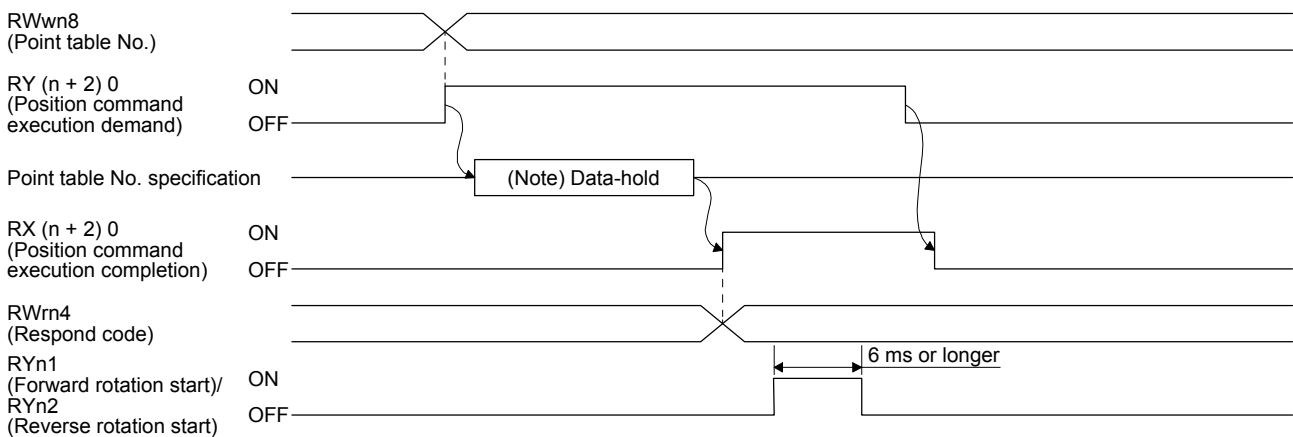

Note. This data is stored in the RAM of the servo amplifier. Thus, the data is cleared when the power supply is shut off.

Set the point table No. in RWwn8 (Point table No.) and turn on RY (n + 2) 0 (Position command execution demand).

Turning on RY (n + 2) 0 stores the point table No. into the RAM of the servo amplifier.

When the data is stored, RX (n + 2) 0 (Position instruction execution completion) turns on.

If data outside the setting range is set in RWwn8 (Point table No.), an error code (refer to section 2.1.4 (3)) is set in respond code.

Turn on RYn1 (Forward rotation start) or RYn2 (Reverse rotation start) after RX (n + 2) 0 (Position instruction execution completion) has turned on.

2. POINT TABLE OPERATION

(2) For the position command data setting and point table No. (speed command) setting

Specify a position address with a remote register, and specify speed command data with a point table No. Then, execute positioning using the servo motor speed, acceleration time constant, and deceleration time constant.

Before executing positioning, set "___ 1" in [Pr. PT62] to enable the operation that follows the settings of the position command data and point table No. (speed command).

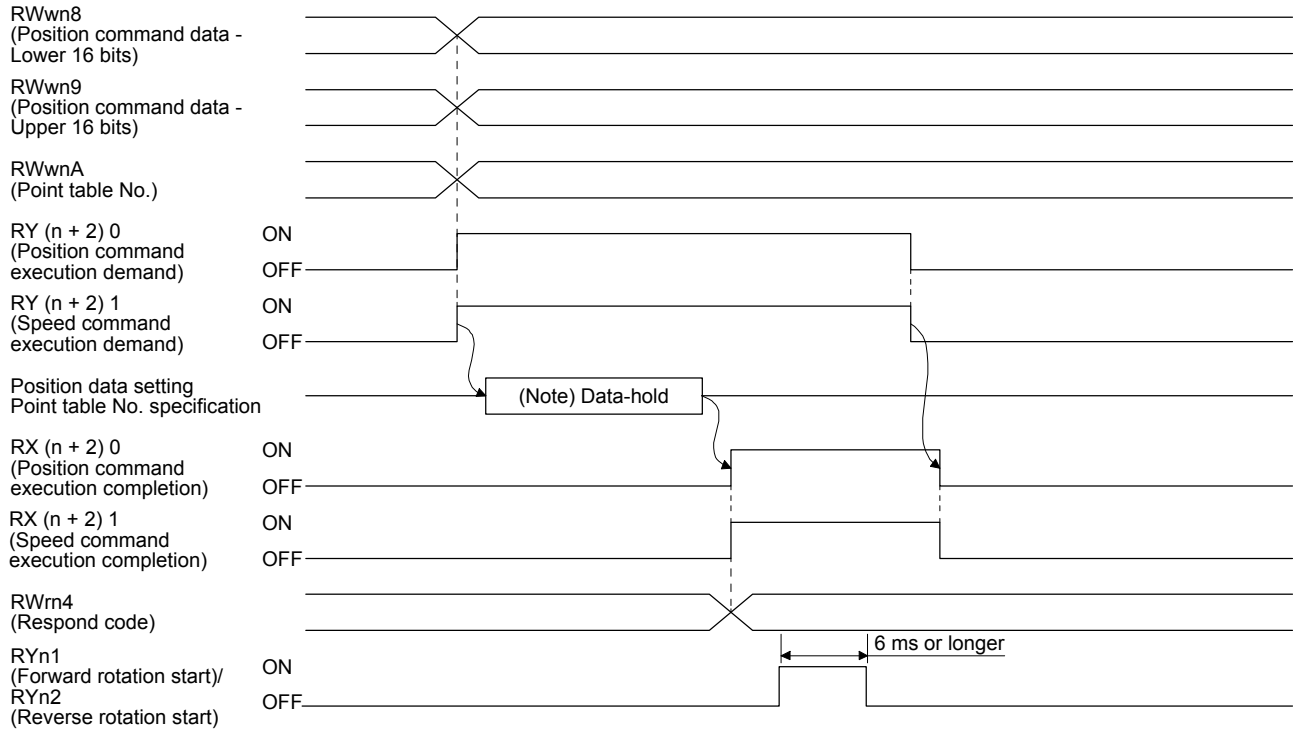

Note. This data is stored in the RAM of the servo amplifier. Thus, the data is cleared when the power supply is shut off.

Set the lower 16 bits of the position command data in RWwn8 (Position command data - Lower 16 bits), the upper 16 bits of the position command data in RWwn9 (Position command data - Upper 16 bits). Set the point table No. for the speed command in RWwnA (Point table No.), and then turn on RY (n + 2) 0 (Position command execution demand) and RY (n + 2) 1 (Speed command execution demand). Turning on RY (n + 2) 0 and RY (n + 2) 1 stores the position command data and point table No. into the RAM of the servo amplifier.

When the data is stored, RX (n + 2) 0 (Position instruction execution completion) and RX (n + 2) 1 (Speed instruction execution completion) turn on.

Until RX (n + 2) 0 and RX (n + 2) 1 turn on after RY (n + 2) 0 and RY (n + 2) 1 are turned on, do not change the settings of the position data and point table No.

If data outside the setting range is set in RWwn8 (Position command data - Lower 16 bits), RWwn9 (Position command data - Upper 16 bits), or RWwnA (Point table No.), an error code (refer to section 2.1.4 (3)) is set in respond code.

Turn on RYn1 (Forward rotation start) or RYn2 (Reverse rotation start) after RX (n + 2) 0 (Position instruction execution completion) and RX (n + 2) 1 (Speed instruction execution completion) have turned on.

2. POINT TABLE OPERATION

(3) For the position command data setting and speed command data setting

Specify a position address and servo motor speed with remote registers, and execute positioning. At this time, the acceleration time constant and deceleration time constant set in point table No. 1 are used.

Before executing positioning, set "___2" in [Pr. PT62] to enable the operation that follows the settings of the position command data and speed command data.

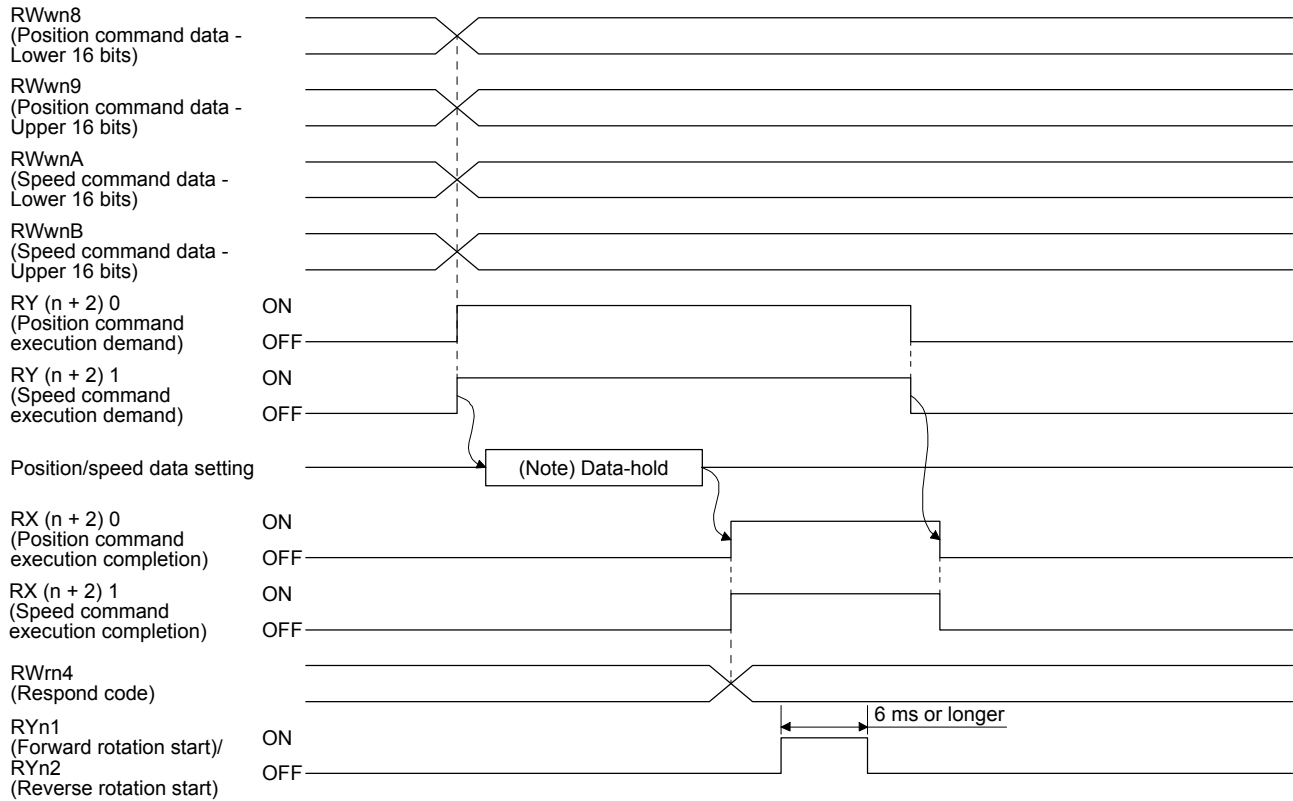

Note. This data is stored in the RAM of the servo amplifier. Thus, the data is cleared when the power supply is shut off.

Set the lower 16 bits of the position command data in RWwn8 (Position command data - Lower 16 bits), the upper 16 bits of the position command data in RWwn9 (Position command data - Upper 16 bits). Set the speed instruction data in RWwnA (Speed command data), and then turn on RY(n+2)0 (Position command execution demand) and RY(n+2)1 (Speed command execution demand).

Turning on RY(n+2)0 and RY(n+2)1 stores the position command data and speed command data into the RAM of the servo amplifier.

When the data is stored, RX(n+2)0 (Position instruction execution completion) and RX(n+2)1 (Speed instruction execution completion) turn on.

If data outside the setting range is set in RWwn8 (Position command data - Lower 16 bits), RWwn9 (Position command data - Upper 16 bits), or RWwnA (Point table No.), an error code (refer to section 2.1.4 (3)) is set in respond code.

Turn on RYn1 (Forward rotation start) or RYn2 (Reverse rotation start) after RX(n+2)0 (Position instruction execution completion) and RX(n+2)1 (Speed instruction execution completion) have turned on.

2. POINT TABLE OPERATION

2.2 Switching power on for the first time

POINT
<p>● To use the servo amplifier in the I/O mode, set [Pr. PN03] to "___ 1". In addition, the GX Works setting is required. For the GX Works setting, refer to section 4.1.4 (2) of "MR-J4-_GF_(-RJ) Servo Amplifier Instruction Manual (Motion Mode)".</p>

When switching the power on for the first time, follow this section to make a startup.

Startup procedure

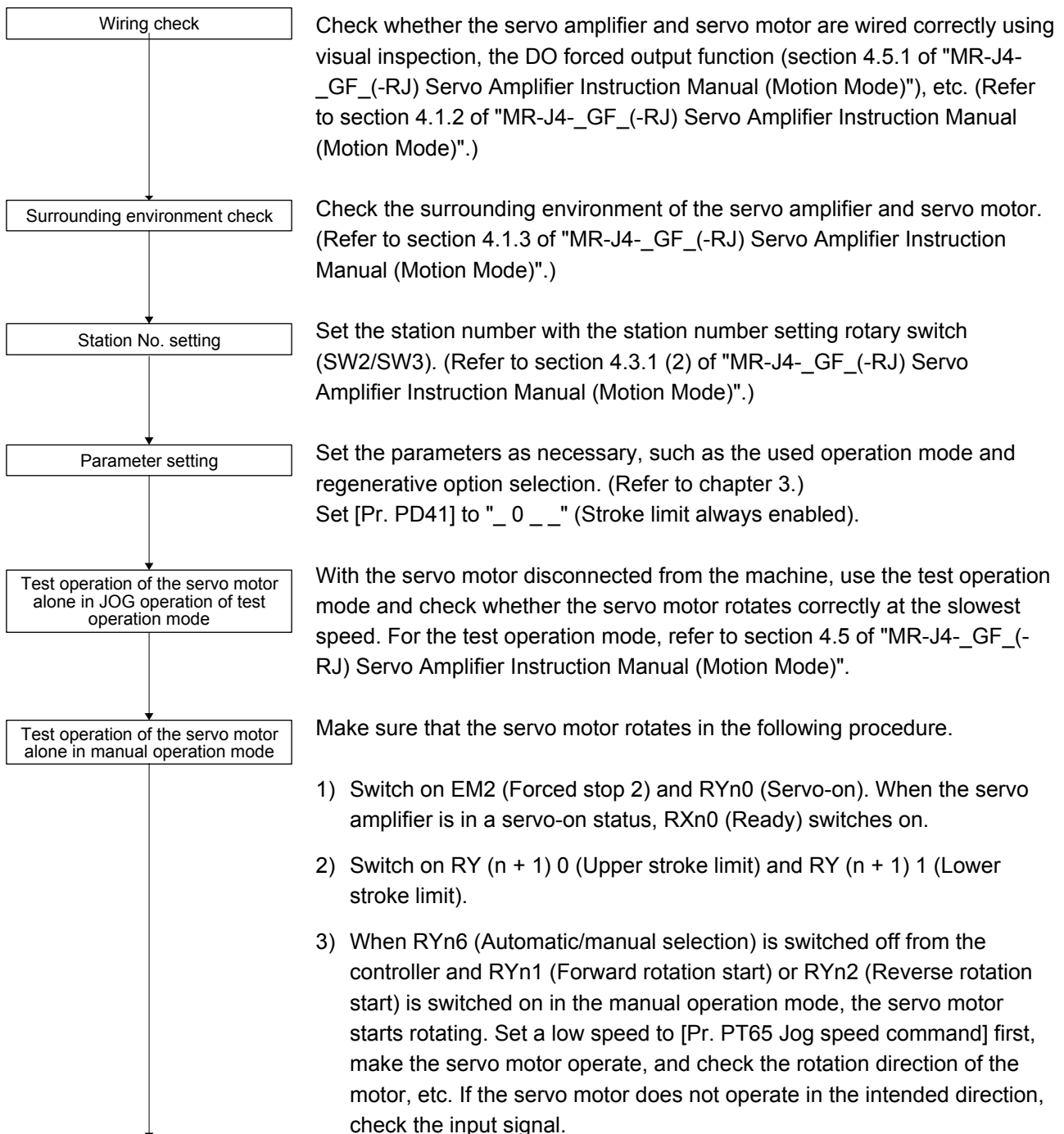

2. POINT TABLE OPERATION

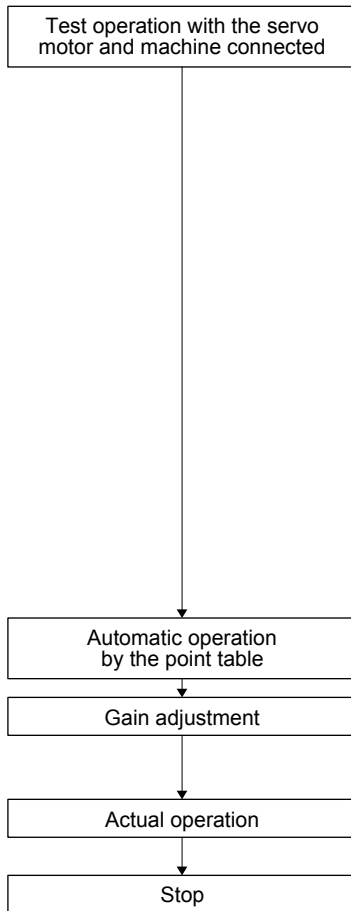

Make sure that the servo motor rotates in the following procedure.

- 1) Switch on EM2 (Forced stop 2) and RYn0 (Servo-on). When the servo amplifier is in a servo-on status, RXn0 (Ready) switches on.
- 2) Switch on RY (n + 1) 0 (Upper stroke limit) and RY (n + 1) 1 (Lower stroke limit).
- 3) When RYn6 (Automatic/manual selection) is switched off from the controller and RYn1 (Forward rotation start) or RYn2 (Reverse rotation start) is switched on in the manual operation mode, the servo motor starts rotating. Set a low speed to [Pr. PT65 Jog speed command] first, make the servo motor operate, and check the operation direction of the machine, etc. If the servo motor does not operate in the intended direction, check the input signal. In the status display, check for any problems of the servo motor speed, load ratio, etc.

Check automatic operation from the controller.

Make gain adjustment to optimize the machine motions. (Refer to chapter 6 of "MR-J4- _GF_(-RJ) Servo Amplifier Instruction Manual (Motion Mode)".)

Stop giving commands and stop operation.

2. POINT TABLE OPERATION

2.3 Automatic operation mode

2.3.1 Automatic operation mode

(1) Command method

Set point tables in advance, and select any point table by using CC-Link IE Field Network communication. Start the operation using RYn1 (Forward rotation start) or RYn2 (Reverse rotation start). Absolute value command method and incremental value command method are provided in automatic operation mode.

(a) Absolute value command method

As position data, set the target address to be reached.

Setting range: -999999 to 999999 [$\times 10^{\text{STM}}$ μm] (STM = Feed length multiplication [Pr. PT03])
 -999999 to 999999 [$\times 10^{(\text{STM}-4)}$ inch] (STM = Feed length multiplication [Pr. PT03])
 -999999 to 999999 [pulse]

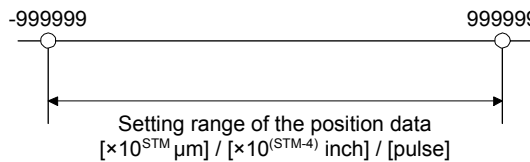

(b) Incremental value command method

As position data, set the travel distance from the current address to the target address.

Setting range: 0 to 999999 [$\times 10^{\text{STM}}$ μm] (STM = Feed length multiplication [Pr. PT03])
 -999999 to 999999 [$\times 10^{(\text{STM}-4)}$ inch] (STM = Feed length multiplication [Pr. PT03])
 -999999 to 999999 [pulse]

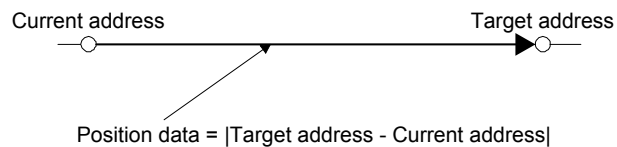

2. POINT TABLE OPERATION

2.3.2 Automatic operation using point table

(1) Absolute value command method

By the sub function of the point table, you can set a point table used under the absolute value command method or the incremental value command method.

(a) Point table

Set the point table values using MR Configurator2 or link devices.

Set the position data, servo motor speed, acceleration time constant, deceleration time constant, dwell and sub function to the point table.

To use the point table under the absolute value command method, set "0", "1", "8", or "9" to the sub function. To use the point table under the incremental value command method, set "2", "3", "10", or "11" to the sub function.

When you set a value outside this range to the point table, the set value will be clamped with the maximum or minimum value. When changing the command unit or the connected motor results in the set value outside this range, [AL. 37] will occur.

Item	Setting range	Unit	Description
Position data	-999999 to 999999 (Note 1)	$\times 10^{\text{STM}}$ μm $\times 10^{(\text{STM}-4)}$ inch pulse	(1) When using this point table under the absolute value command method Set the target address (absolute value). (2) When using this point table under the incremental value command method Set the travel distance. A "-" sign indicates a reverse rotation command.
Servo motor speed	0 to permissible speed	r/min mm/s (Note 2)	Set the command speed of the servo motor for execution of positioning. The setting value must be within the permissible instantaneous speed of the servo motor used. If a value smaller than "1" is set for the servo motor speed, the servo motor may not rotate.
Acceleration time constant	0 to 20000	ms	Set a time until the servo motor rotates at the rated speed.
Deceleration time constant	0 to 20000	ms	Set a time from when the servo motor rotates at the rated speed until when the motor stops.
Dwell	0 to 20000	ms	Set the dwell. To disable the dwell, set "0" or "2" to the sub function. To perform continuous operation, set "1", "3", "8", "9", "10" or "11" to the sub function and 0 to the dwell. When the dwell is set, the position command of the selected point table is completed, and after the set dwell has elapsed, the position command of the next point table is started.

2. POINT TABLE OPERATION

Item	Setting range	Unit	Description
Sub function	0 to 3, 8 to 11		<p>Set the sub function.</p> <p>(1) When using this point table under the absolute value command method</p> <p>0: Automatic operation is performed in accordance with a single point table selected.</p> <p>1: Automatic continuous operation is performed to the next point table without a stop.</p> <p>8: Automatic continuous operation is performed without a stop to the point table selected at start-up.</p> <p>9: Automatic continuous operation is performed without stopping a point table No. 1.</p> <p>(2) When using this point table under the incremental value command method</p> <p>2: Automatic operation is performed in accordance with a single point table selected.</p> <p>3: Automatic continuous operation is performed to the next point table without a stop.</p> <p>10: Automatic continuous operation is performed to the point table selected at start-up.</p> <p>11: Automatic continuous operation is performed without stopping a point table No. 1.</p> <p>When a different rotation direction is set, smoothing zero (command output) is confirmed and then the rotation direction is reversed.</p> <p>Setting "1" or "3" to point table No.255 results in an error.</p> <p>Refer to (3) (b) of this section.</p>

- Note
1. When the unit of the position data is μm or inch, the location of the decimal point is changed according to the STM setting.
 2. The unit will be "mm/s" in the linear servo motor control mode.

(b) Parameter setting

Set the following parameters to perform automatic operation.

1) Command method selection ([Pr. PT01])

Select the absolute value command method as shown below.



2) Rotation direction selection ([Pr. PA14])

Select the servo motor rotation direction when RYn1 (Forward rotation start) is switched on.

[Pr. PA14] setting	Servo motor rotation direction when RYn1 (Forward rotation start) is switched on
0	CCW rotation with + position data CW rotation with - position data
1	CW rotation with + position data CCW rotation with - position data

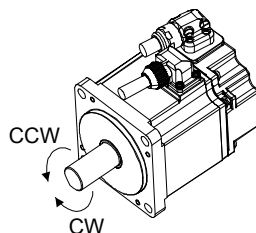

2. POINT TABLE OPERATION

- 3) Position data unit ([Pr. PT01])
Set the unit of the position data.

[Pr. PT01] setting	Position data unit
_ 0 _	mm
_ 1 _	inch
_ 3 _	pulse

- 4) Feed length multiplication ([Pr. PT03])
Set the feed length multiplication (STM) of the position data.

[Pr. PT03] setting	Position data input range		
	[mm]	[inch]	[pulse] (Note 1)
___ 0	- 999.999 to + 999.999	- 99.9999 to + 99.9999	- 999999 to + 999999
___ 1	- 9999.99 to + 9999.99	- 999.999 to + 999.999	
___ 2	- 99999.9 to + 99999.9	- 9999.99 to + 9999.99	
___ 3	- 999999 to + 999999	- 99999.9 to + 99999.9	

Note. The feed length multiplication setting ([Pr. PT03]) is not applied to the unit multiplication factor.
Adjust the unit multiplication factor in the electronic gear setting ([Pr. PA06] and [Pr. PA07]).

(c) Operation

Selecting RWwn6 for the point table and switching on RYn1 starts positioning to the position data at the set speed, acceleration time constant and deceleration time constant. At this time, RYn2 (Reverse rotation start) is invalid.

Item	Used device	Description
Automatic operation mode selection	RYn6 (Automatic/manual selection)	Switch on RYn6.
Point table selection	RWwn6 (Point table No. selection)	Set the point table No. to use.
Start	RYn1 (Forward rotation start)	Switch on RYn1 to start.

2. POINT TABLE OPERATION

(2) Incremental value command method

POINT
<p>● The incremental value command method ([Pr. PT01] = ___ 1) is not available in the absolute position detection system. When using the absolute position detection system, select the absolute value command method ([Pr. PT01] = ___ 0).</p>

(a) Point table

Set the point table values using MR Configurator2 or link devices.

Set the position data, servo motor speed, acceleration time constant, deceleration time constant, dwell and sub function to the point table.

When you set a value outside the setting range to the point table, the set value will be clamped with the maximum or minimum value. When changing the command unit or the connected motor results in the set value outside the setting range, [AL. 37] will occur.

Item	Setting range	Unit	Description
Position data	0 to 999999 (Note 1)	$\times 10^{\text{STM}}$ μm $\times 10^{(\text{STM}-4)}$ inch pulse	Set the travel distance. The unit can be changed by [Pr. PT03] (Feed length multiplication).
Servo motor speed	0 to permissible speed	r/min mm/s (Note 2)	Set the command speed of the servo motor for execution of positioning. The setting value must be the permissible instantaneous speed or less of the servo motor used.
Acceleration time constant	0 to 20000	ms	Set a time until the servo motor rotates at the rated speed.
Deceleration time constant	0 to 20000	ms	Set a time from when the servo motor rotates at the rated speed until when the motor stops.
Dwell	0 to 20000	ms	Set the dwell. To disable the dwell, set "0" to the sub function. To perform continuous operation, set "1", "8" or "9" to the sub function and 0 to the dwell. When the dwell is set, the position command of the selected point table is completed, and after the set dwell has elapsed, the position command of the next point table is started.
Sub function	0, 1, 8 to 9		Set the sub function. 0: Automatic operation is performed in accordance with a single point table selected. 1: Automatic continuous operation is performed to the next point table without a stop. 8: Automatic continuous operation is performed without a stop to the point table selected at start-up. 9: Automatic continuous operation is performed without stopping a point table No. 1. Refer to section 4.2.2 for details.

Note 1. When the unit of the position data is μm or inch, the location of the decimal point is changed according to the STM setting.

2. The unit will be "mm/s" in the linear servo motor control mode.

2. POINT TABLE OPERATION

(b) Parameter setting

Set the following parameters to perform automatic operation.

1) Command method selection ([Pr. PT01])

Select the incremental value command method as shown below.

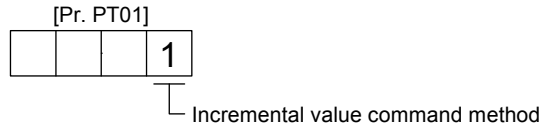

2) Rotation direction selection ([Pr. PA14])

Select the servo motor rotation direction when RYn1 (Forward rotation start) or RYn2 (Reverse rotation start) is switched on.

[Pr. PA14] setting	Servo motor rotation direction	
	RYn1 (Forward rotation start)	RYn2 (Reverse rotation start)
0	CCW rotation (address increase)	CW rotation (address decrease)
1	CW rotation (address increase)	CCW rotation (address decrease)

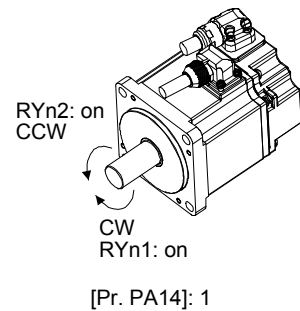
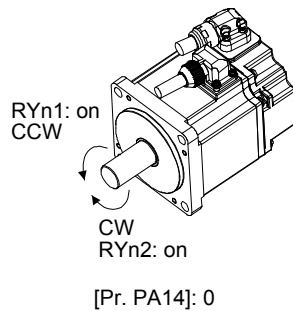

3) Position data unit ([Pr. PT01])

Set the unit of the position data.

[Pr. PT01] setting	Position data unit
_ 0 _ _	mm
_ 1 _ _	inch
_ 3 _ _	pulse

4) Feed length multiplication ([Pr. PT03])

Set the feed length multiplication (STM) of the position data.

[Pr. PT03] setting	Position data input range		
	[mm]	[inch]	[pulse] (Note)
___ 0	0 to + 999.999	0 to + 99.9999	0 to + 999999
___ 1	0 to + 9999.99	0 to + 999.999	
___ 2	0 to + 99999.9	0 to + 9999.99	
___ 3	0 to + 999999	0 to + 99999.9	

Note. The feed length multiplication setting ([Pr. PT03]) is not applied to the unit multiplication factor. Adjust the unit multiplication factor in the electronic gear setting ([Pr. PA06] and [Pr. PA07]).

2. POINT TABLE OPERATION

(c) Operation

Selecting RWwn6 for the point table and switching on RYn1 starts a forward rotation of the motor over the travel distance of the position data at the set speed, acceleration time constant and deceleration time constant.

Switching on RYn2 starts a reverse rotation of the motor in accordance with the values set to the selected point table.

When the positioning operation is performed consecutively under the incremental value command method, the servo motor rotates in the same direction only.

To change the travel direction during continuous operation, perform the operation under the absolute value command method.

Item	Used device	Description
Automatic operation mode selection	RYn6 (Automatic/manual selection)	Switch on RYn6.
Point table selection	RWwn6 (Point table No. selection)	Set the point table No. to use.
Start	RYn1 (Forward rotation start)	Switch on RYn1 to start.
	RYn2 (Reverse rotation start)	Switch on RYn2 to start.

2. POINT TABLE OPERATION

(3) Automatic operation timing chart

(a) Automatic individual positioning operation

1) Absolute value command method ([Pr. PT01] = ___ 0)

While the servo motor is stopped under servo-on state, switching on RYn1 (Forward rotation start) starts the automatic positioning operation.

The following shows a timing chart.

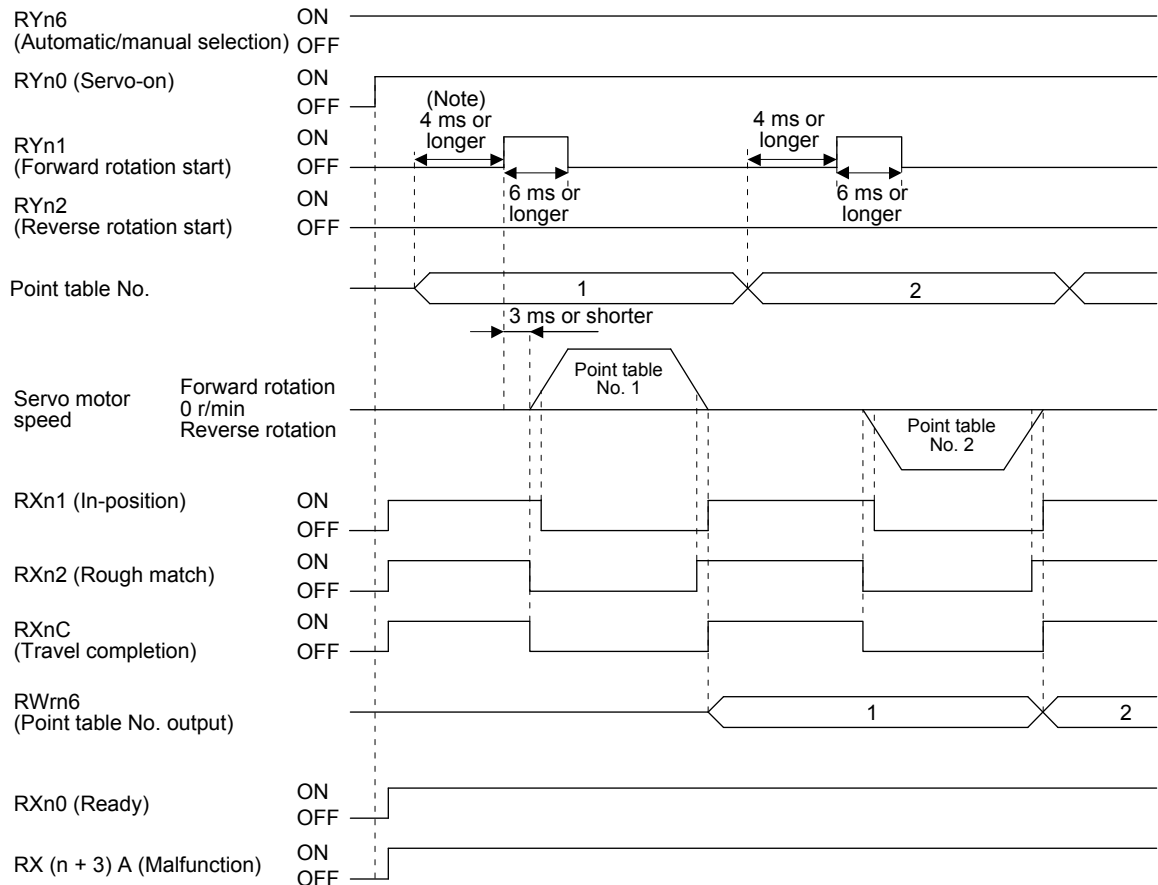

Note. The detection of external input signals is delayed by the set time in the input filter setting of [Pr. PD11].

Considering the output signal sequence from the controller and signal variations due to hardware, configure a sequence that changes the point table selection earlier.

2. POINT TABLE OPERATION

2) Incremental value command method ([Pr. PT01] = ___ 1)

While the servo motor is stopped under servo-on state, switching on RYn1 (Forward rotation start) or RYn2 (Reverse rotation start) starts the automatic positioning operation.

The following shows a timing chart.

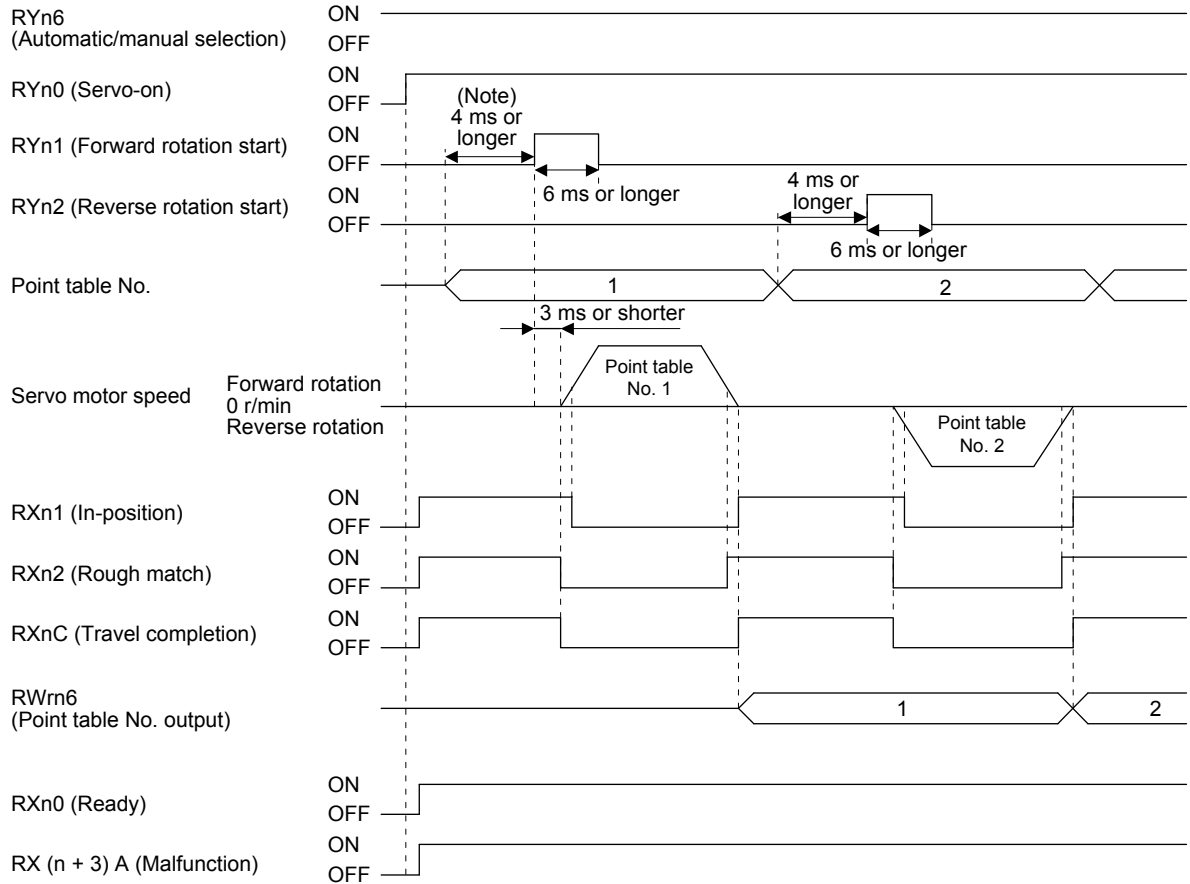

Note. The detection of external input signals is delayed by the set time in the input filter setting of [Pr. PD11].

Considering the output signal sequence from the controller and signal variations due to hardware, configure a sequence that changes the point table selection earlier.

2. POINT TABLE OPERATION

(b) Automatic continuous positioning operation

By merely selecting a point table and switching on RYn1 (Forward rotation start) or RYn2 (Reverse rotation start), the operation can be performed in accordance with the point tables having consecutive numbers.

1) Absolute value command method ([Pr. PT01] = ___ 0)

By specifying the absolute value command or the incremental value command in the sub function of the point table, the automatic continuous operation can be performed.

The following shows how to set.

Point table setting		
Dwell	Sub function	
	When position data is absolute value	When position data is incremental value
1 or more	1	3

a) Positioning in a single direction

The following shows an operation example with the set values listed in the table below.

In this example, point table No. 1 and point table No. 3 are under the absolute value command method, and point table No. 2 is under the incremental value command method.

Point table No.	Position data [10 ^{STM} μm]	Servo motor speed [r/min]	Acceleration time constant [ms]	Deceleration time constant [ms]	Dwell [ms]	Sub function
1	5.00	3000	100	150	100	1
2	5.00	2000	150	200	200	3
3	15.00	1000	300	100	Disabled	0 (Note)

Note. Always set "0" or "2" to the sub function of the last point table among the consecutive point tables.

0: When using the point table under the absolute value command method

2: When using the point table under the incremental value command method

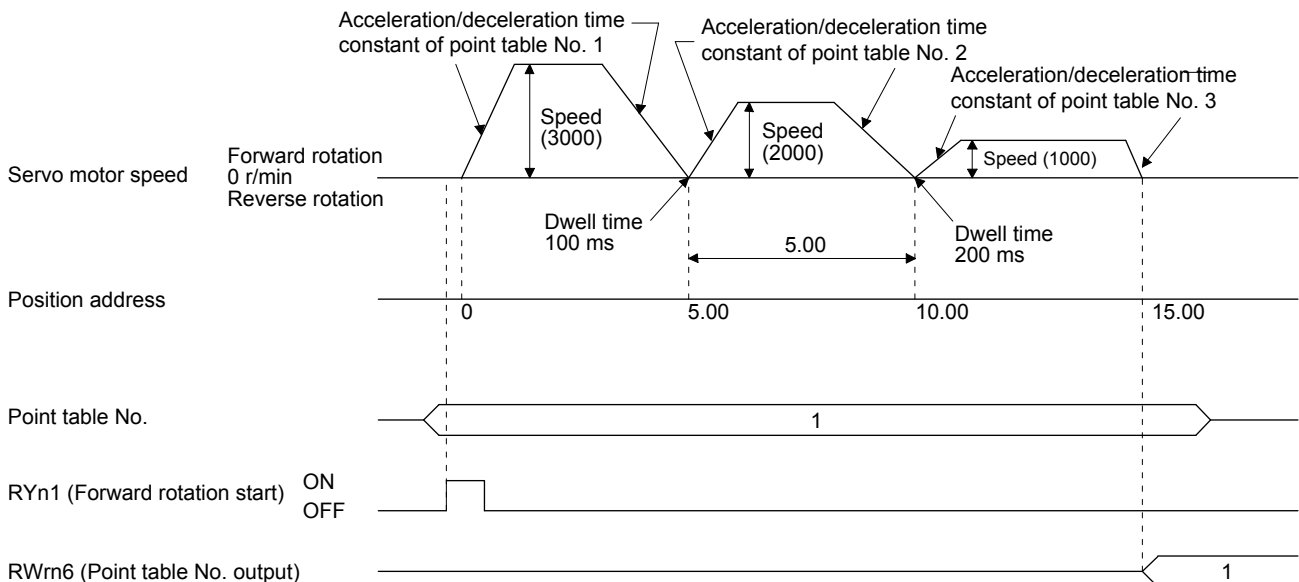

2. POINT TABLE OPERATION

b) Positioning in the reverse direction midway

The following shows an operation example with the set values listed in the table below.

In this example, point table No. 1 and point table No. 3 are under the absolute value command method, and point table No. 2 is under the incremental value command method.

Point table No.	Position data [10 ^{STM} μm]	Servo motor speed [r/min]	Acceleration time constant [ms]	Deceleration time constant [ms]	Dwell [ms]	Sub function
1	5.00	3000	100	150	100	1
2	7.00	2000	150	200	200	3
3	8.00	1000	300	100	Disabled	0 (Note)

Note. Always set "0" or "2" to the sub function of the last point table among the consecutive point tables.

0: When using the point table under the absolute value command method

2: When using the point table under the incremental value command method

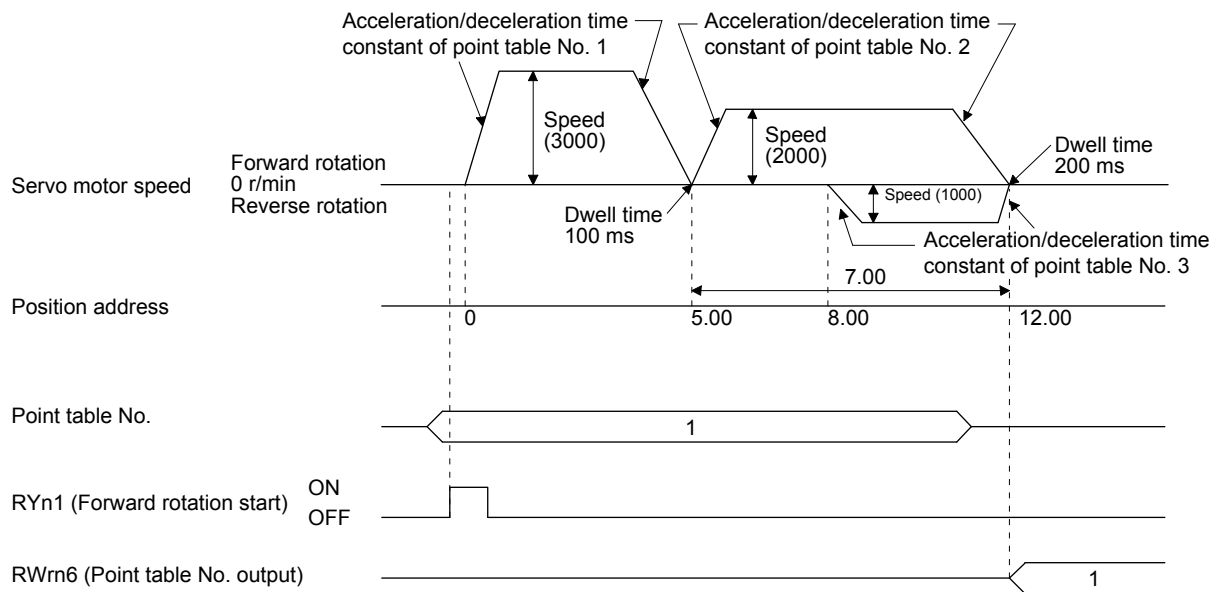

2. POINT TABLE OPERATION

2) Incremental value command method ([Pr. PT01] = ___ 1)

The position data of the incremental value command method is the sum of the position data of consecutive point tables.

The following shows how to set.

Point table setting	
Dwell	Sub function
1 or more	1

a) Positioning in a single direction

The following shows an operation example with the set values listed in the table below.

Point table No.	Position data [10 ^{STM} μm]	Servo motor speed [r/min]	Acceleration time constant [ms]	Deceleration time constant [ms]	Dwell [ms]	Sub function
1	5.00	3000	100	150	100	1
2	6.00	2000	150	200	200	1
3	3.00	1000	300	100	Disabled	0 (Note)

Note. Always set "0" to the sub function of the last point table among the consecutive point tables.

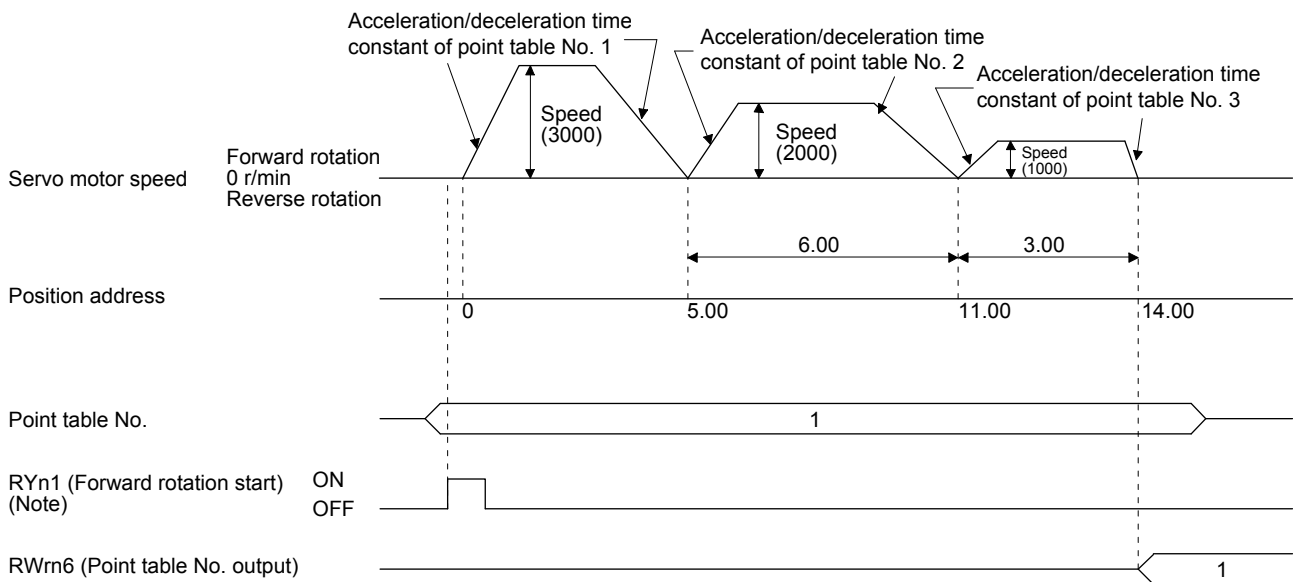

Note. Switching on RYn2 (Reverse rotation start) starts positioning in the reverse rotation direction.

2. POINT TABLE OPERATION

(c) Varying-speed operation

By setting the sub function of the point table, the servo motor speed during positioning can be changed. Point tables are used by the number of the set speed.

1) Absolute value command method ([Pr. PT01] = ___ 0)

Set "1" or "3" to the sub function to execute the positioning at the speed set in the following point table.

At this time, the position data selected at start is valid, and the acceleration/deceleration time constant set in the next and subsequent point tables is invalid.

By setting "1" or "3" to sub functions until point table No. 254, the operation can be performed at maximum 255 speeds.

Always set "0" or "2" to the sub function of the last point table.

To perform varying-speed operation, always set "0" to the dwell.

Setting "1" or more will enables the automatic continuous positioning operation.

The following table shows an example of setting.

Point table No.	Dwell [ms] (Note 1)	Sub function	Varying-speed operation
1	0	1	Consecutive point table data
2	0	3	
3	Disabled	0 (Note 2)	
4	0	3	Consecutive point table data
5	0	1	
6	Disabled	2 (Note 2)	

Note 1. Always set "0".

2. Always set "0" or "2" to the sub function of the last point table among the consecutive point tables.

2. POINT TABLE OPERATION

a) Positioning in a single direction

The following shows an operation example with the set values listed in the table below.

In this example, point table No. 1 and point table No. 3 are under the absolute value command method, and point table No. 2 is under the incremental value command method.

Point table No.	Position data [10 ⁵ TM μm]	Servo motor speed [r/min]	Acceleration time constant [ms]	Deceleration time constant [ms]	Dwell [ms] (Note 1)	Sub function
1	5.00	3000	100	150	0	1
2	3.00	2000	Disabled	Disabled	0	3
3	10.00	1000	Disabled	Disabled	0	1
4	6.00	500	Disabled	Disabled	Disabled	2 (Note 2)

Note 1. Always set "0".

2. Always set "0" or "2" to the sub function of the last point table among the consecutive point tables.

0: When using the point table under the absolute value command method

2: When using the point table under the incremental value command method

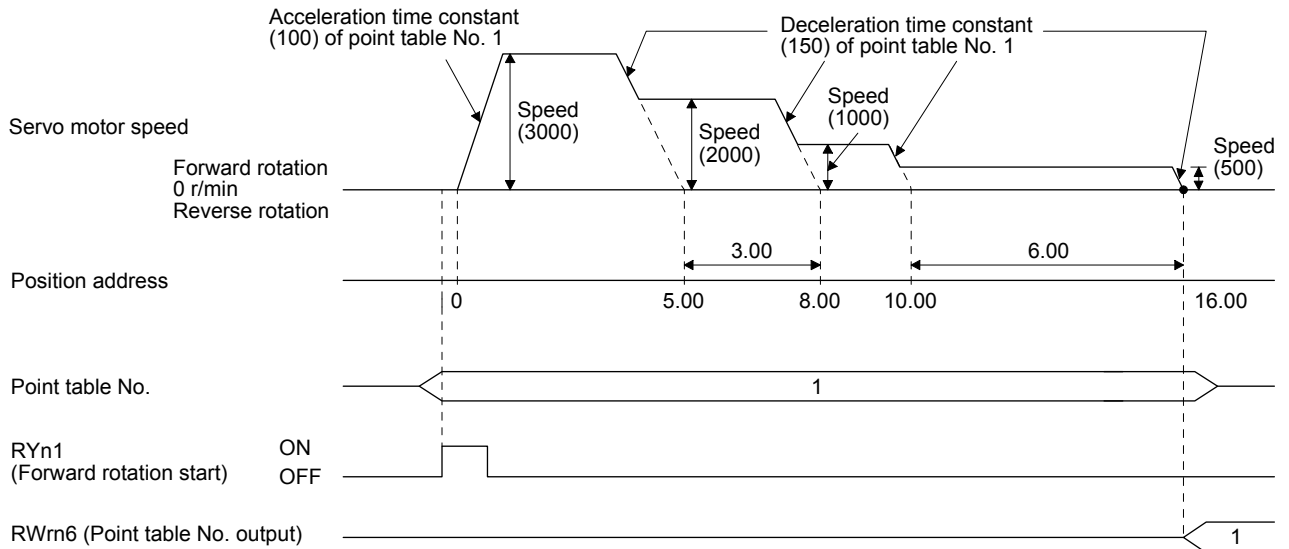

2. POINT TABLE OPERATION

b) Positioning in the reverse direction midway

The following shows an operation example with the set values listed in the table below.

In this example, point table No. 1 and point table No. 3 are under the absolute value command method, and point table No. 2 is under the incremental value command method.

Point table No.	Position data [10 ⁵ μm]	Servo motor speed [r/min]	Acceleration time constant [ms]	Deceleration time constant [ms]	Dwell [ms] (Note 1)	Sub function
1	5.00	3000	100	150	0	1
2	7.00	2000	Disabled	Disabled	0	3
3	8.00	1000	Disabled	Disabled	Disabled	0 (Note 2)

Note 1. Always set "0".

2. Always set "0" or "2" to the sub function of the last point table among the consecutive point tables.

0: When using the point table under the absolute value command method

2: When using the point table under the incremental value command method

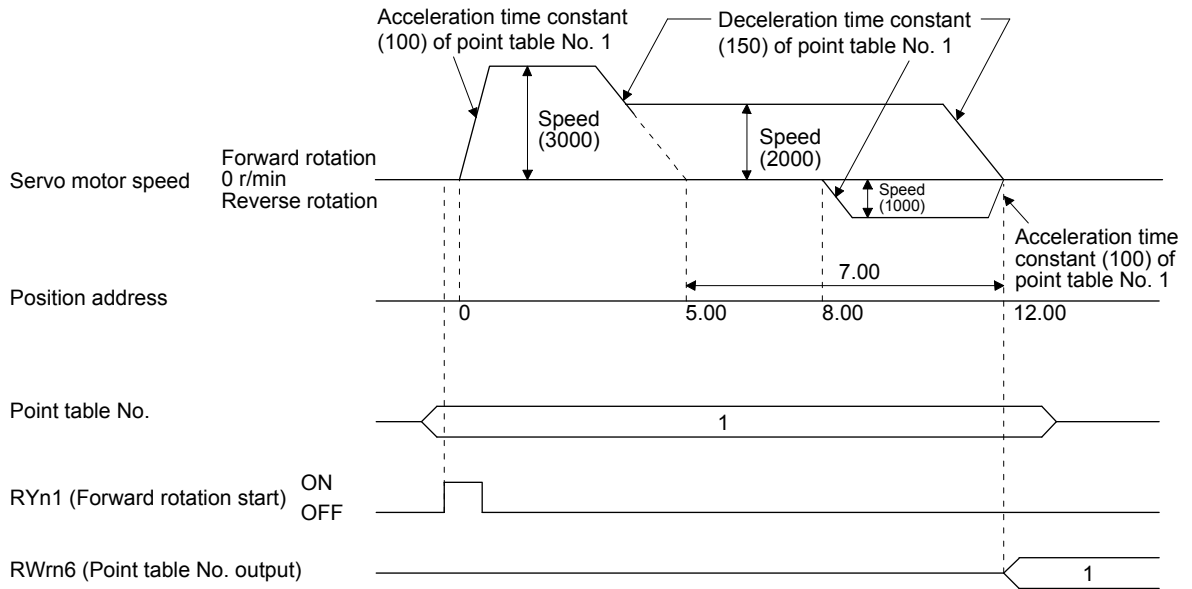

2. POINT TABLE OPERATION

2) Incremental value command method ([Pr. PT01] = ___ 1)

Setting "1" to the sub function executes positioning at the speed set in the following point table. At this time, the position data selected at start is valid, and the acceleration/deceleration time constant set in the next and subsequent point tables is invalid.

By setting "1" to sub functions until point table No. 254, the operation can be performed at maximum 255 speeds.

Always set "0" to the sub function of the last point table.

To perform varying-speed operation, always set "0" to the dwell.

Setting "1" or more will enable the automatic continuous positioning operation.

The following table shows an example of setting.

Point table No.	Dwell [ms] (Note 1)	Sub function	Varying-speed operation
1	0	1	Consecutive point table data
2	0	1	
3	Disabled	0 (Note 2)	
4	0	1	Consecutive point table data
5	0	1	
6	Disabled	0 (Note 2)	

Note 1. Always set "0".

2. Always set "0" to the sub function of the last point table among the consecutive point tables.

The following shows an operation example with the set values listed in the table below.

Point table No.	Position data [10 ⁵ μm]	Servo motor speed [r/min]	Acceleration time constant [ms]	Deceleration time constant [ms]	Dwell [ms] (Note 1)	Sub function
1	5.00	3000	100	150	0	1
2	3.00	2000	Disabled	Disabled	0	1
3	2.00	1000	Disabled	Disabled	0	1
4	6.00	500	Disabled	Disabled	Disabled	0 (Note 2)

Note 1. Always set "0".

2. Always set "0" to the sub function of the last point table among the consecutive point tables.

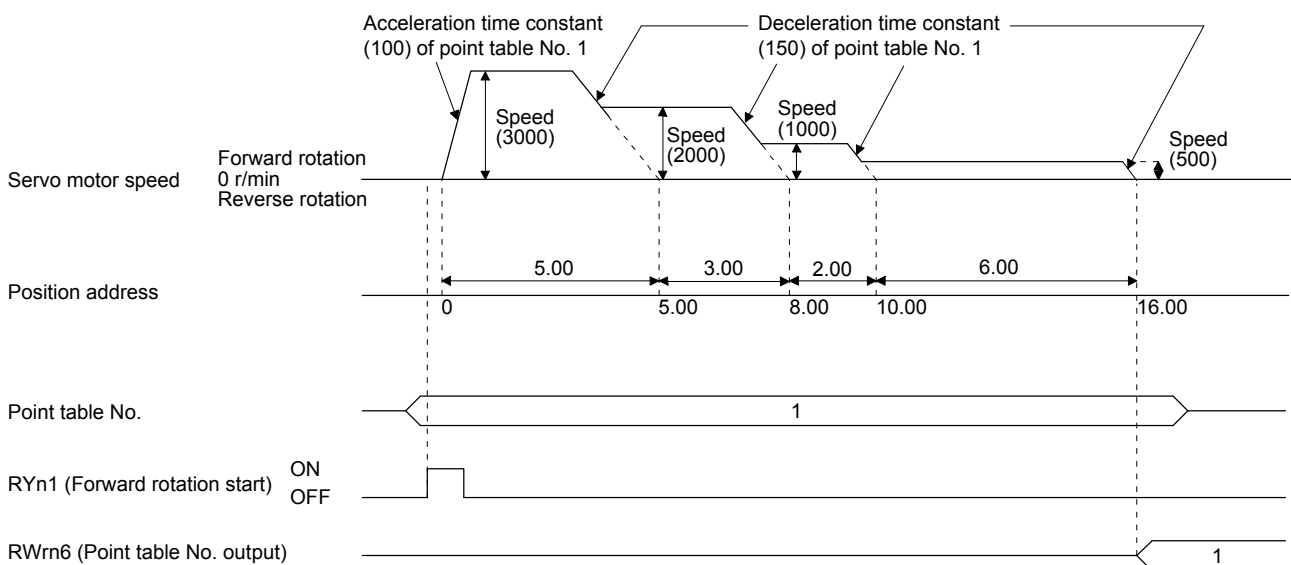

2. POINT TABLE OPERATION

(d) Automatic repeat positioning operation

By setting the sub function of the point table, the operation pattern of the set point table No. can be returned to, and the positioning operation can be performed repeatedly.

1) Absolute value command method ([Pr. PT01] = ___ 0)

Setting "8" or "10" to the sub function performs automatic continuous operation or varying-speed operation until that point table, and after the completion of positioning, performs the operation again from the operation pattern of the point table No. used at start-up.

Setting "9" or "11" to the sub function performs automatic continuous operation or varying-speed operation until that point table, and after the completion of positioning, performs the operation again from the operation pattern of point table No. 1.

a) Automatic repeat positioning operation by absolute value command method

Example 1. Operations when "8" is set to the sub function of point table No. 4

Point table No.	Position data [10 ⁵ μm]	Servo motor speed [r/min]	Acceleration time constant [ms]	Deceleration time constant [ms]	Dwell [ms]	Sub function
1	4.00	1500	200	100	150	1
2	5.00	3000	100	150	100	1
3	5.00	2000	150	200	200	3
4	15.00	1000	300	100	150	8

Operation sequence

1) Starting with point table No. 2

2) Executing point table No. 3

3) Executing point table No. 4

4) Executing again point table No.2 used at start-up when "8" is set to the sub function of point table No. 4

5) Repeating the above execution in the sequence of 2) to 3) to 4) to 2) to 3) to 4)

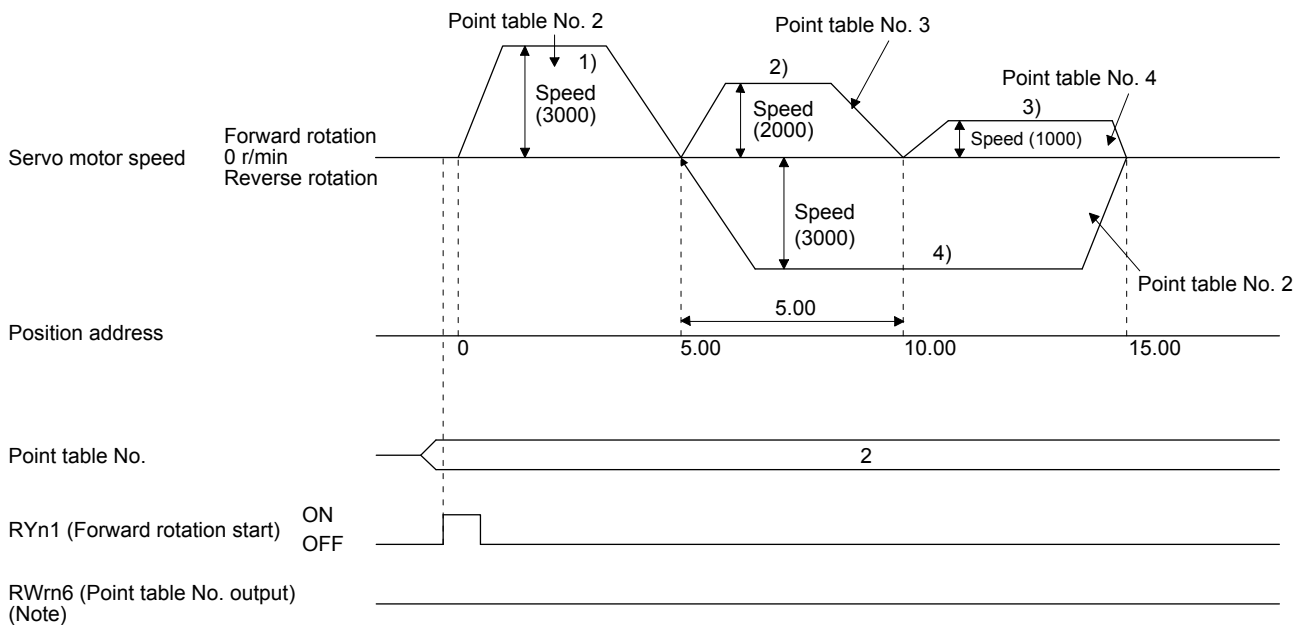

Note. RWn6 is not outputted in automatic continuous operation.

2. POINT TABLE OPERATION

Example 2. Operations when "9" is set to the sub function of point table No. 3

Point table No.	Position data [10 ^{STM} μm]	Servo motor speed [r/min]	Acceleration time constant [ms]	Deceleration time constant [ms]	Dwell [ms]	Sub function
1	0.00	3000	100	150	100	1
2	5.00	2000	150	200	200	1
3	15.00	1000	300	100	150	9

Operation sequence

- 1) Starting with point table No. 2
- 2) Executing point table No. 3
- 3) Executing point table No.1 when "9" is set to the sub function of point table No. 3
- 4) Repeating the above execution in the sequence of 1) to 2) to 3) to 1) to 2) to 3)

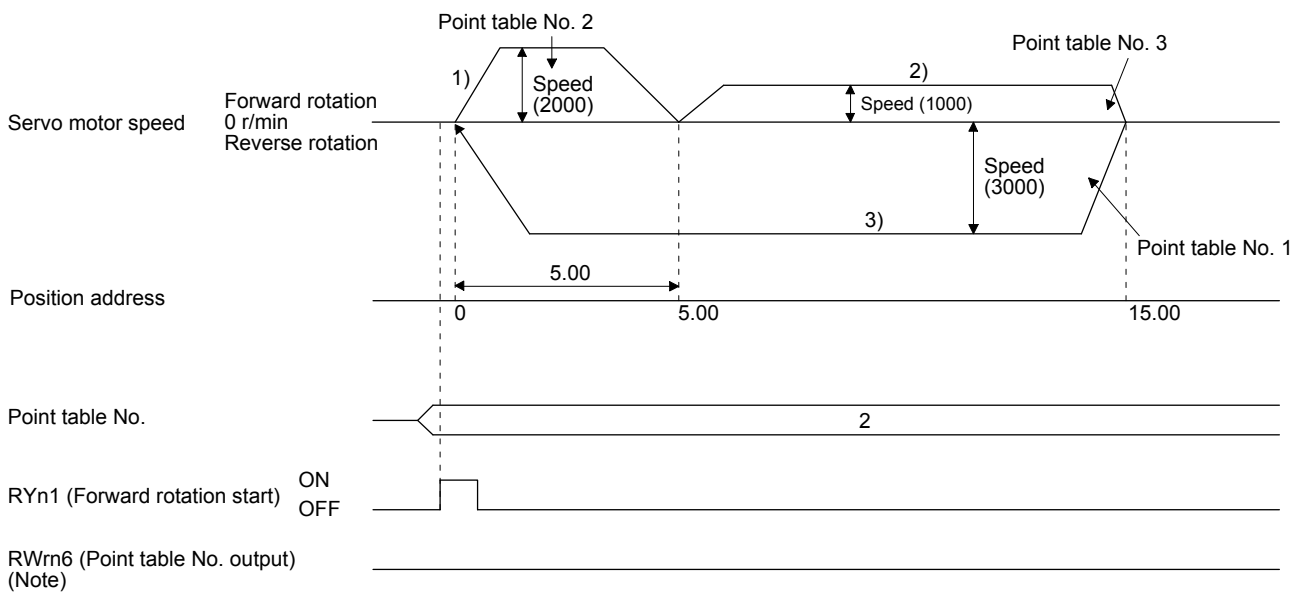

Note. RWn6 is not outputted in automatic continuous operation.

2. POINT TABLE OPERATION

b) Automatic repeat positioning operation by incremental value command method

Example 1. Operations when "10" is set to the sub function of point table No. 4

Point table No.	Position data [10 ^{STM} μm]	Servo motor speed [r/min]	Acceleration time constant [ms]	Deceleration time constant [ms]	Dwell [ms]	Sub function
1	4.00	1500	200	100	150	1
2	5.00	3000	100	150	100	3
3	10.00	2000	150	200	200	1
4	5.00	1000	300	100	150	10

Operation sequence

- 1) Starting with point table No. 2
- 2) Executing point table No. 3
- 3) Executing point table No. 4
- 4) Executing again point table No.2 used at start-up when "10" is set to the sub function of point table No. 4
- 5) Repeating the above execution in the sequence of 1) to 2) to 3) to 4) to 2) to 3) to 4)

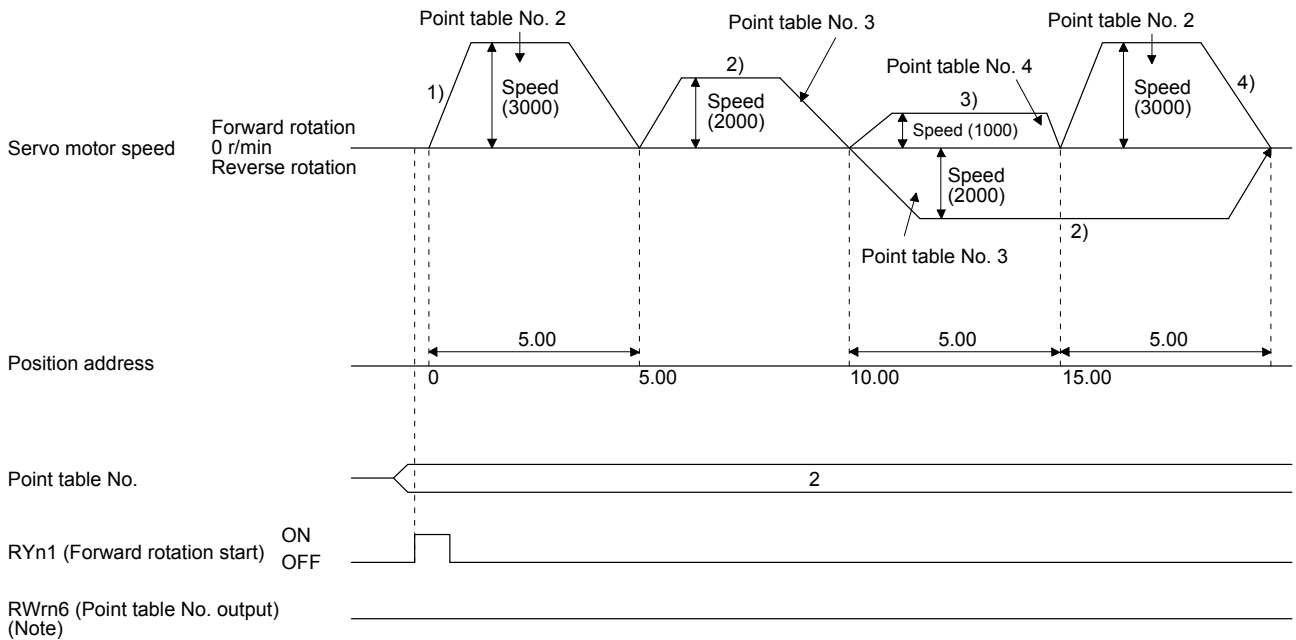

Note. RWrn6 is not outputted in automatic continuous operation.

2. POINT TABLE OPERATION

Example 2. Operations when "11" is set to the sub function of point table No. 3

Point table No.	Position data [10 ^{STM} μm]	Servo motor speed [r/min]	Acceleration time constant [ms]	Deceleration time constant [ms]	Dwell [ms]	Sub function
1	5.00	3000	100	150	100	3
2	10.00	2000	150	200	200	1
3	5.00	1000	300	100	150	11

Operation sequence

- 1) Starting with point table No. 2
- 2) Executing point table No. 3
- 3) Executing point table No.1 when "11" is set to the sub function of point table No. 3
- 4) Repeating the above execution in the sequence of 1) to 2) to 3) to 1) to 2) to 3)

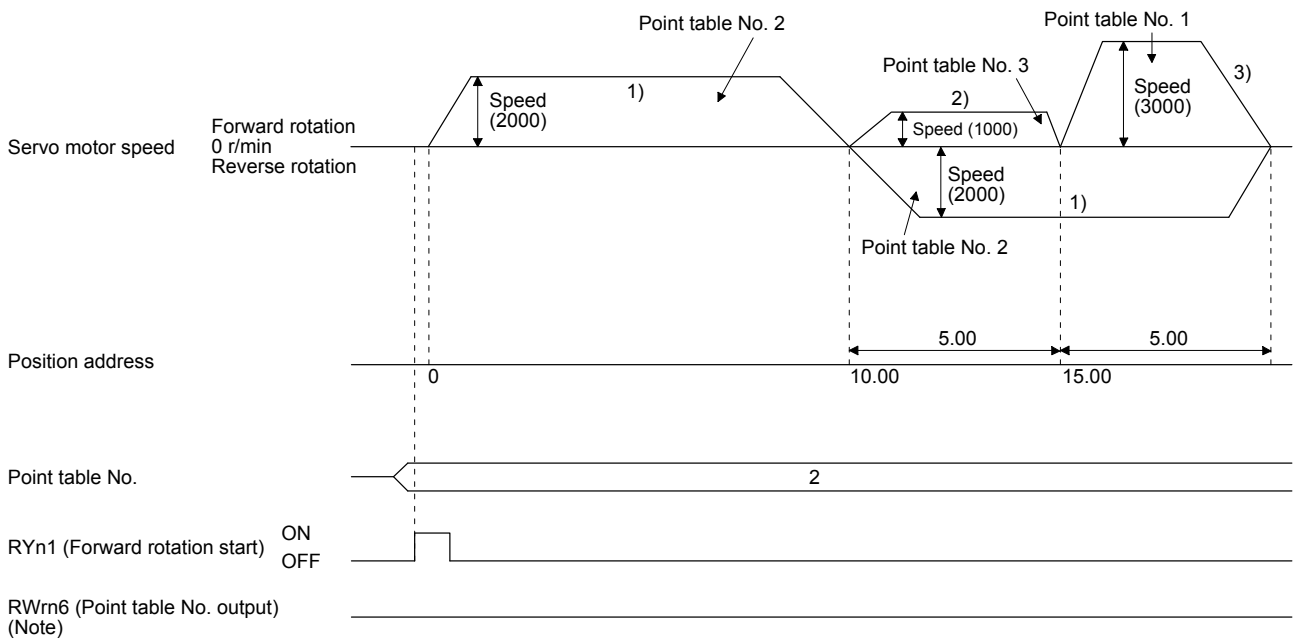

Note. RWrn6 is not outputted in automatic continuous operation.

2. POINT TABLE OPERATION

c) Varying-speed operation by absolute value command method

Example. Operations when "8" is set to the sub function of point table No. 3

Point table No.	Position data [10 ^{STM} μm]	Servo motor speed [r/min]	Acceleration time constant [ms]	Deceleration time constant [ms]	Dwell [ms]	Sub function
1	5.00	3000	100	150	0	1
2	5.00	2000	Disabled	Disabled	0	3
3	15.00	1000	Disabled	Disabled	0	8

Operation sequence

- 1) Starting with point table No. 1
- 2) Varying the speed and executing point table No. 2
- 3) Varying the speed and executing point table No. 3
- 4) Executing point table No.1 used at start-up in CW direction when "8" is set to the sub function of point table No. 3
- 5) Repeating the above execution in the sequence of 1) to 2) to 3) to 4) to 2) to 3) to 4)

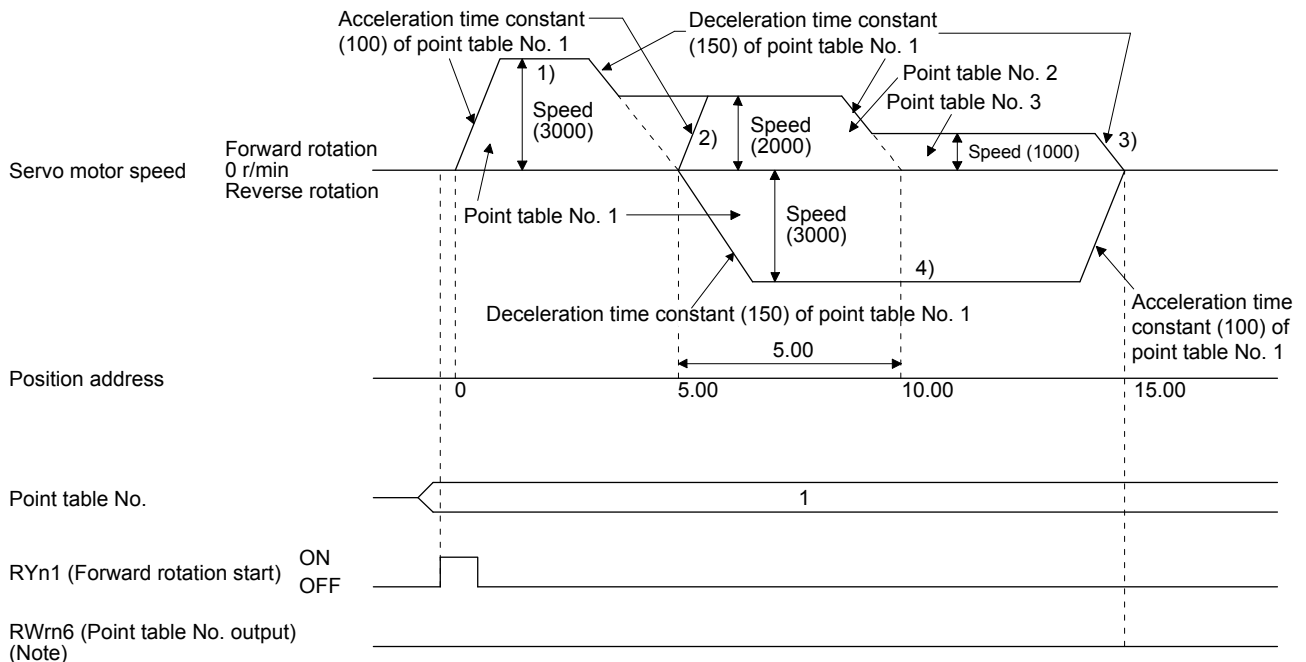

Note. RWrn6 is not outputted in automatic continuous operation.

2. POINT TABLE OPERATION

d) Varying-speed operation by incremental value command method

Example. Operations when "10" is set to the sub function of point table No. 3

Point table No.	Position data [10 ^{STM} μm]	Servo motor speed [r/min]	Acceleration time constant [ms]	Deceleration time constant [ms]	Dwell [ms]	Sub function
1	5.00	3000	100	150	0	3
2	10.00	2000	150	200	0	1
3	5.00	1000	300	100	0	10

Operation sequence

- 1) Starting with point table No. 1
- 2) Varying the speed and executing point table No. 2
- 3) Varying the speed and executing point table No. 3
- 4) Varying the speed, and executing point table No.1 when "10" is set to the sub function of point table No. 3
- 5) Repeating the above execution in the sequence of 1) to 2) to 3) to 4) to 2) to 3) to 4)

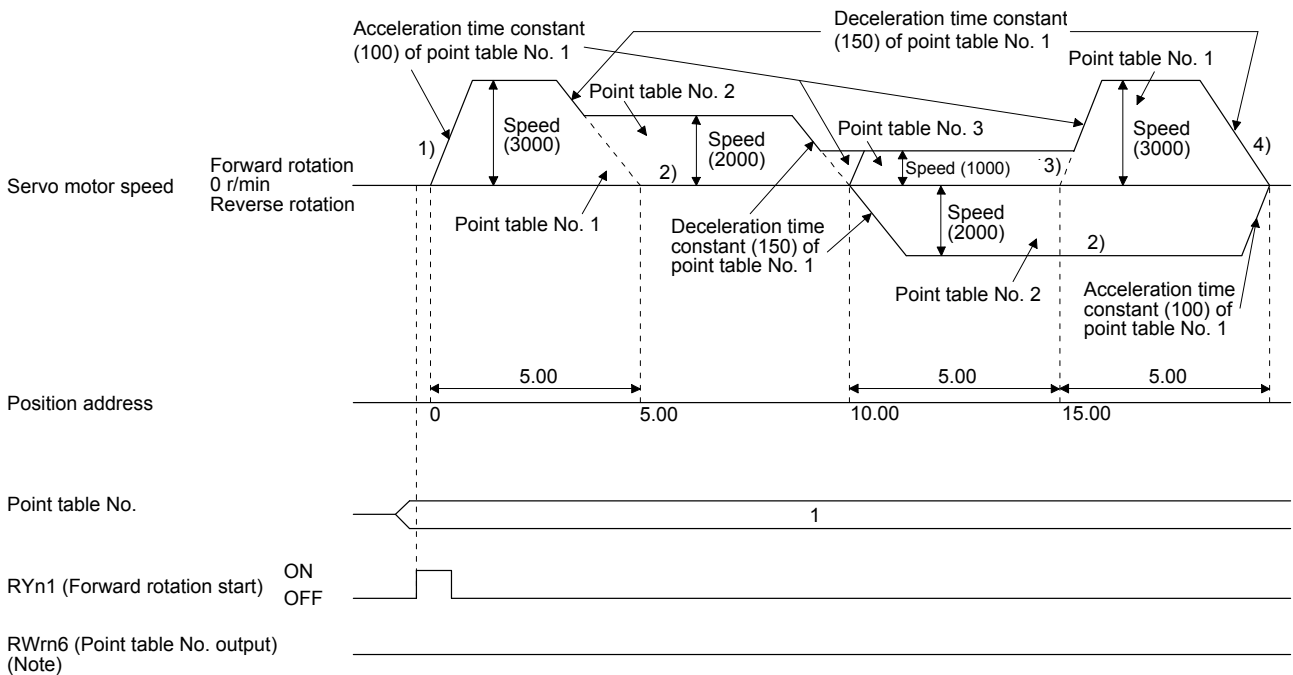

Note. RWn6 is not outputted in automatic continuous operation.

2. POINT TABLE OPERATION

2) Incremental value command method ([Pr. PT01] = ___ 1)

Setting "8" to the sub function performs automatic continuous operation or varying-speed operation until that point table, and after the completion of positioning, performs the operation again from the operation pattern of the set point table.

Setting "9" to the sub function performs automatic continuous operation or varying-speed operation until that point table, and after the completion of positioning, performs the operation again from the operation pattern of point table No. 1.

a) Automatic repeat positioning operation by incremental value command method

Example 1. Operations when "8" is set to the sub function of point table No. 3

Point table No.	Position data [10 ^{STM} μm]	Servo motor speed [r/min]	Acceleration time constant [ms]	Deceleration time constant [ms]	Dwell [ms]	Sub function
1	4.00	1500	200	100	150	1
2	5.00	3000	100	150	100	1
3	6.00	2000	150	200	200	8

Operation sequence

1) Starting with point table No. 2

2) Executing point table No. 3

3) Executing again point table No.2 used at start-up when "8" is set to the sub function of point table No. 3

4) Repeating the above execution in the sequence of 1) to 2) to 3) to 2) to 3)

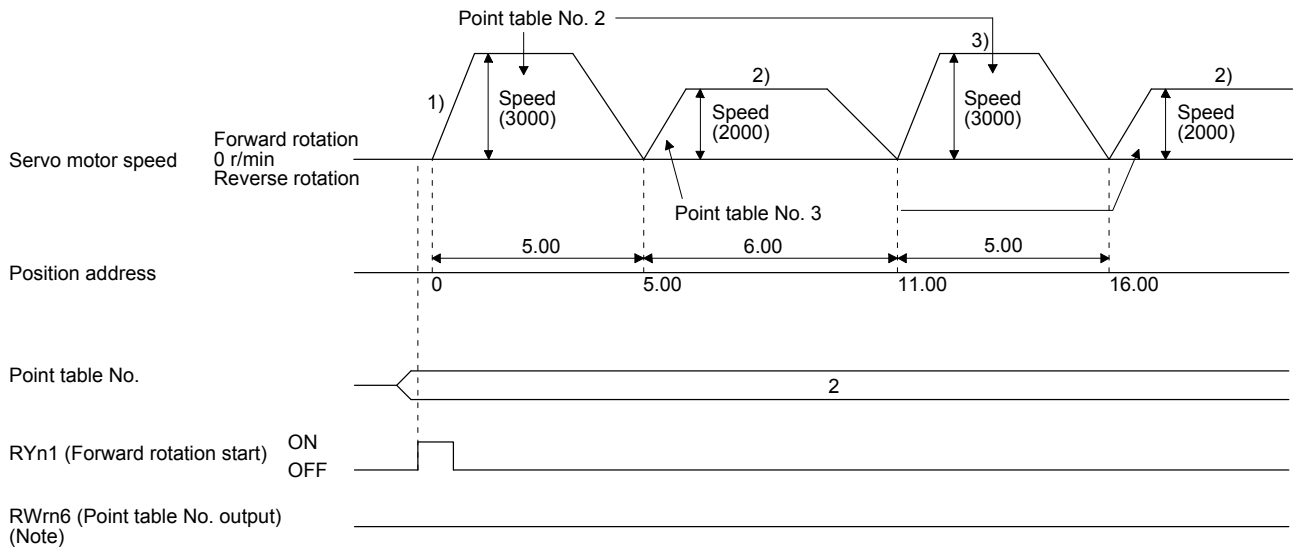

Note. RWrn6 is not outputted in automatic continuous operation.

2. POINT TABLE OPERATION

Example 2. Operations when "9" is set to the sub function of point table No. 2

Point table No.	Position data [10 ^{STM} μm]	Servo motor speed [r/min]	Acceleration time constant [ms]	Deceleration time constant [ms]	Dwell [ms]	Sub function
1	5.00	3000	100	150	100	1
2	6.00	2000	150	200	200	9

Operation sequence

- 1) Starting with point table No. 2
- 2) Executing point table No.1 when "9" is set to the sub function of point table No. 2
- 3) Repeating the above execution in the sequence of 1) to 2) to 1) to 2)

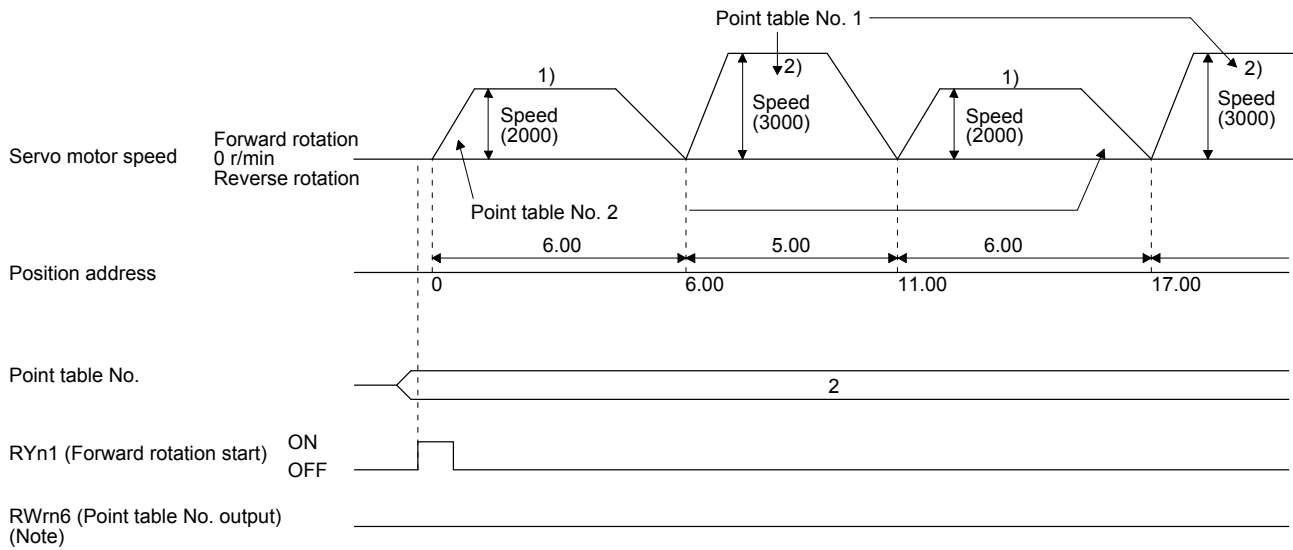

Note. RWrn6 is not outputted in automatic continuous operation.

2. POINT TABLE OPERATION

b) Varying-speed operation by incremental value command method

Example. Operations when "8" is set to the sub function of point table No. 2

Point table No.	Position data [10 ^{STM} μm]	Servo motor speed [r/min]	Acceleration time constant [ms]	Deceleration time constant [ms]	Dwell [ms]	Sub function
1	5.00	3000	100	150	0	1
2	6.00	2000	Disabled	Disabled	0	8

Operation sequence

- 1) Starting with point table No. 1
- 2) Varying the speed and executing point table No. 2
- 3) Executing again point table No.1 used at start-up when "8" is set to the sub function of point table No. 2
- 4) Repeating the above execution in the sequence of 1) to 2) to 3) to 2) to 3)

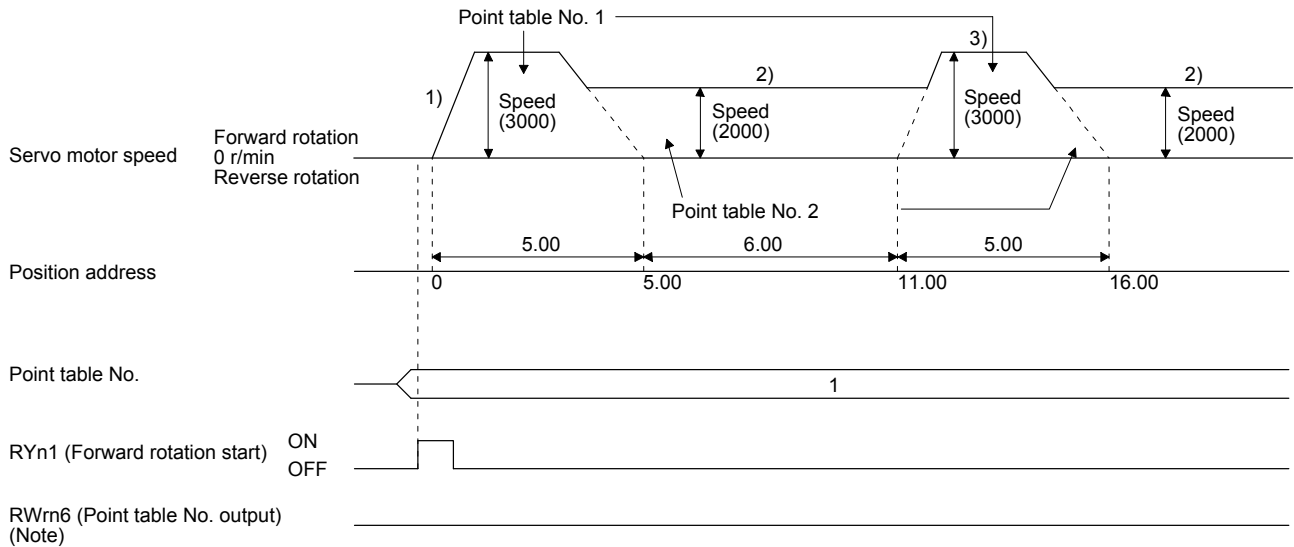

Note. RWrn6 is not outputted in automatic continuous operation.

2. POINT TABLE OPERATION

(e) Temporary stop/restart

When RYn7 (Temporary stop/restart) is switched on during automatic operation, the servo motor decelerates with the deceleration time constant of the point table being executed, and then stops temporarily.

Switching on RYn7 (Temporary stop/restart) again restarts the servo motor rotation for the remaining distance.

During a temporary stop, RYn1 (Forward rotation start) or RYn2 (Reverse rotation start) does not function even if it is switched on.

When any of the following conditions is satisfied during a temporary stop, the remaining travel distance is cleared and the temporary stop is reset.

- The operation mode is switched from the automatic mode to the manual mode.
- The servo motor enters the servo-off status.
- The stroke limit or software limit is detected.
- The controller is reset.

The temporary stop/restart input functions in the following states.

Operation status	Automatic operation	Manual operation	Home position return
During a stop		Temporary stop	Temporary stop
During acceleration	Temporary stop	Temporary stop	Temporary stop
At a constant speed	Temporary stop	Temporary stop	Temporary stop
During deceleration		Temporary stop	Temporary stop
During a temporary stop	Restart	Restart	Stop

1) When the servo motor is rotating

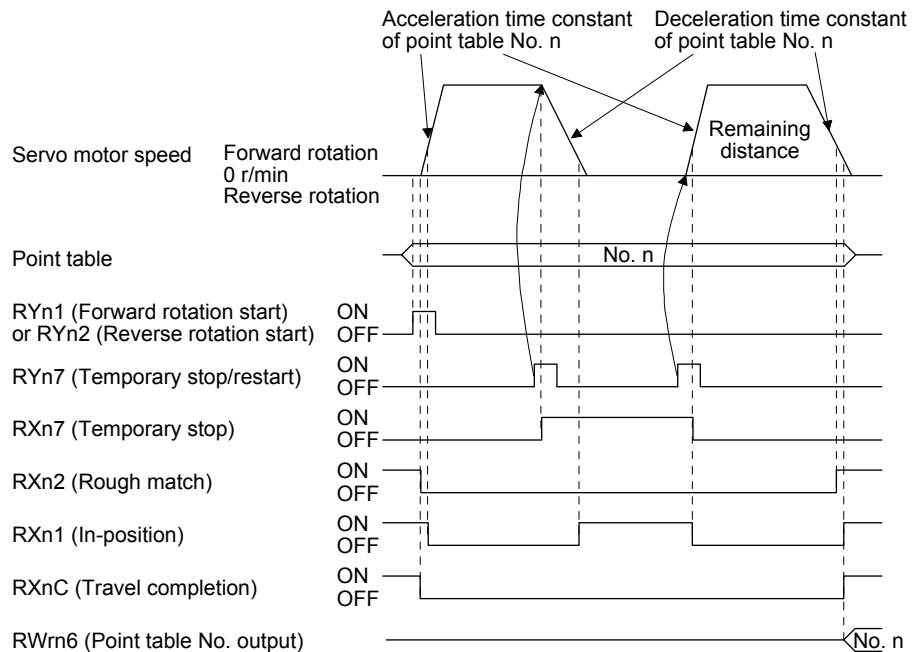

2. POINT TABLE OPERATION

2) During dwell

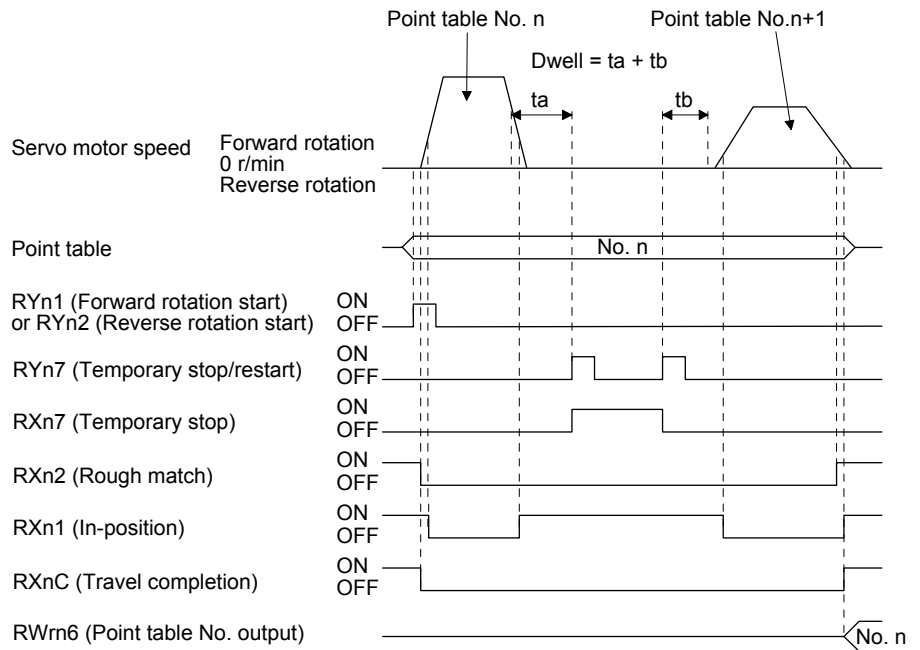

(f) Suspension of automatic operation

To stop the automatic operation, stop the servo motor with RYn7 (Temporary stop/restart), switch off RYn6 (Automatic/manual selection), and then set to the manual mode. The remaining travel distance is cleared.

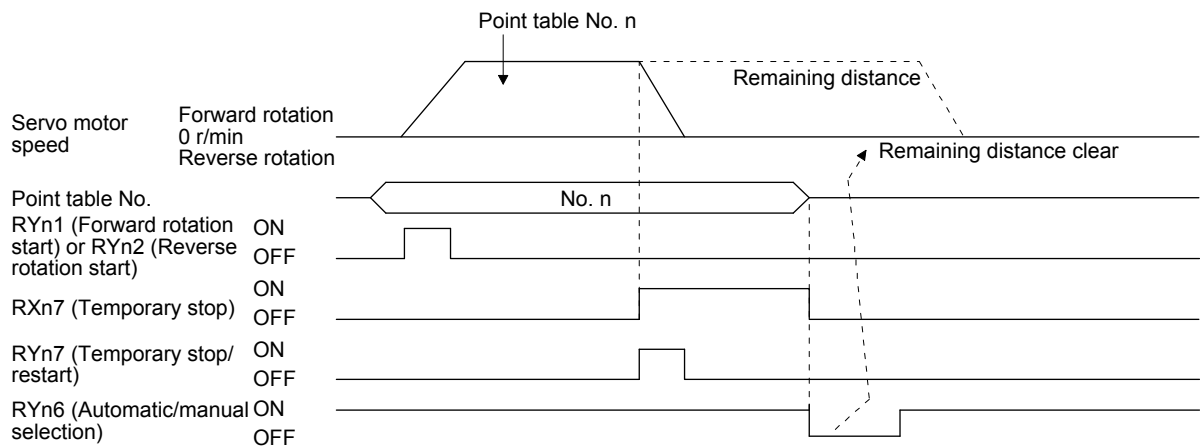

2. POINT TABLE OPERATION

(g) Changing the operation mode

When the operation mode is changed, wait for 6 ms or more after the change, and then turn on RYn1 (Forward rotation start) or RYn2 (Reverse rotation start).

Changing the operation mode during operation will stop the operation in execution and decelerate the servo motor to a stop. Before turning on RYn1 (Forward rotation start) or RYn2 (Reverse rotation start), make sure that RXnC (Travel completion) is turned on.

1) When you change the operation mode while the operation is being stopped

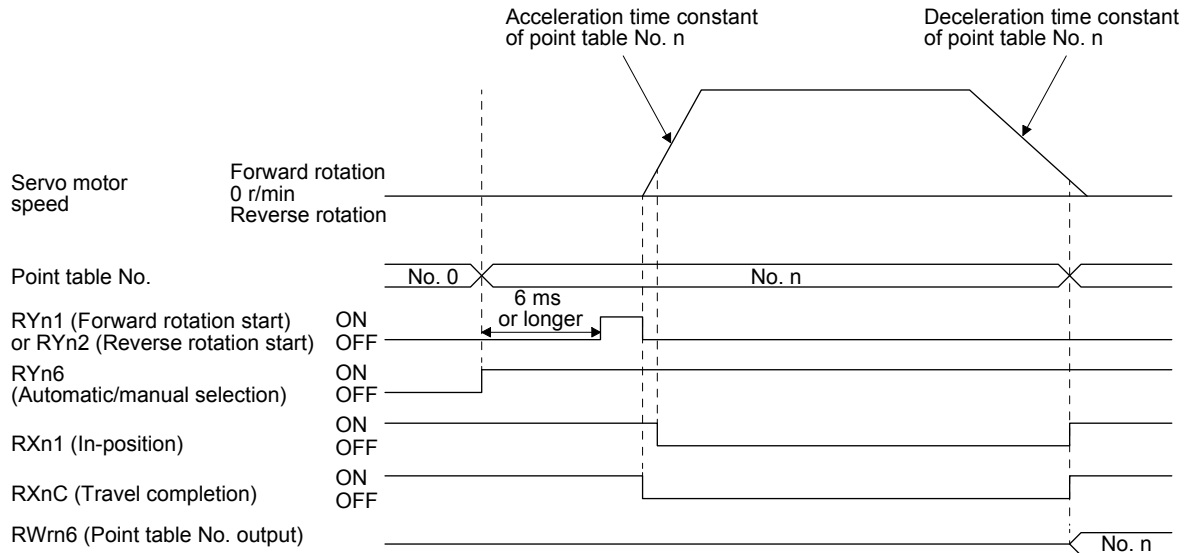

2) When you change the operation mode during operation (from the point table operation to JOG operation)

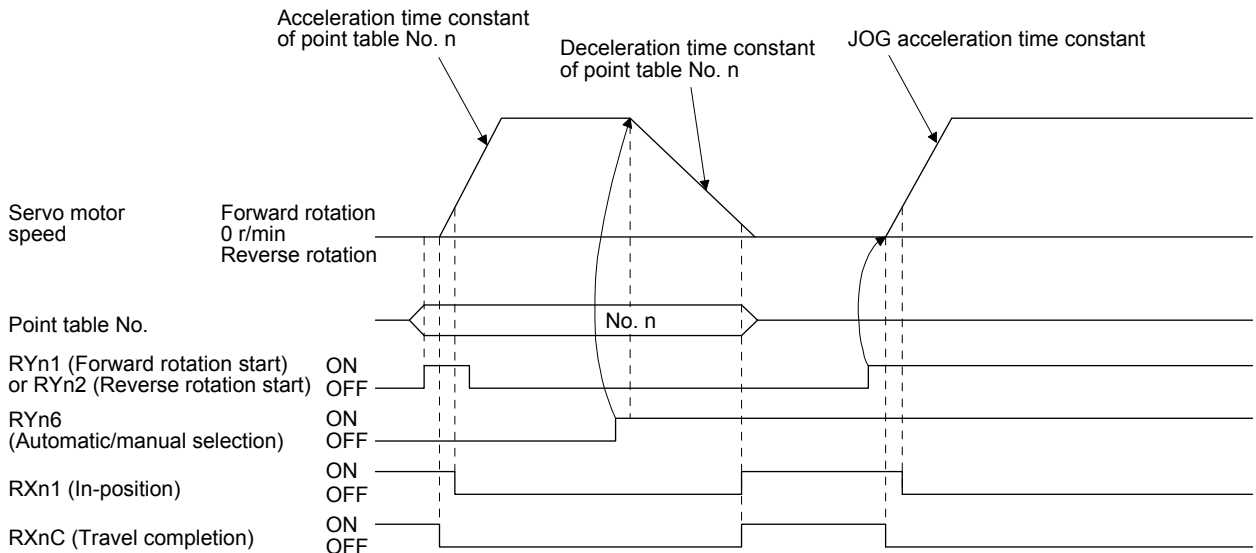

2. POINT TABLE OPERATION

- 3) When you change the operation mode during operation (from the point table operation to home position return)

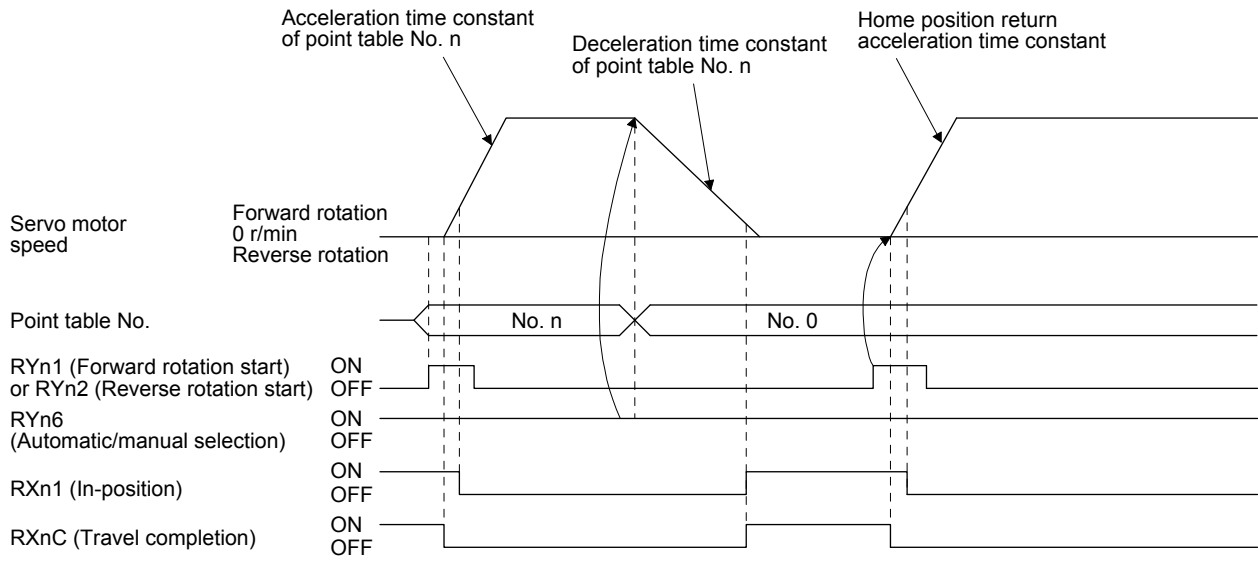

2. POINT TABLE OPERATION

2.4 Manual operation mode

For the machine adjustment, home position adjustment, and others, positioning to any point is possible using the JOG operation.

2.4.1 JOG operation

(1) Setting

According to the purpose of use, set input devices and parameters as shown below. In this case, RWwn6 (Point table No. selection) is disabled.

Item	Used device/parameter	Setting
Manual operation mode selection	RYn6 (Automatic/manual selection)	Switch off RYn6.
Servo motor rotation direction	[Pr. PA14]	Refer to (2) of this section.
JOG speed	[Pr. PT65]	Set the servo motor speed.
Acceleration/deceleration time constant	Acceleration time constant: [Pr. PT49] Deceleration time constant: [Pr. PT50]	Set an acceleration time constant and deceleration time constant.

(2) Servo motor rotation direction

[Pr. PA14] setting	Servo motor rotation direction	
	RYn1 (Forward rotation start) on	RYn2 (Reverse rotation start) on
0	CCW rotation	CW rotation
1	CW rotation	CCW rotation

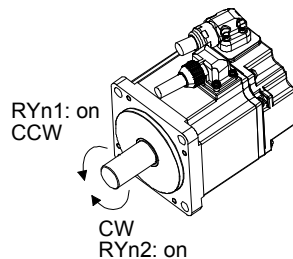

[Pr. PA14]: 0

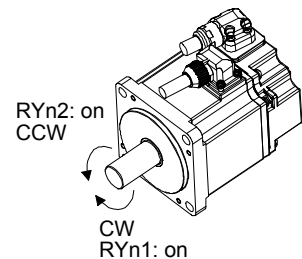

[Pr. PA14]: 1

(3) Operation

Turning on RYn1 (Forward rotation start) performs the operation according to the JOG speed, acceleration time constant, and deceleration time constant set with parameters. For the rotation direction, refer to (2) of this section. Switching on RYn2 (Reverse rotation start) starts the rotation in the reverse direction of RYn1 (Forward rotation start).

Simultaneously switching on or off RYn1 (Forward rotation start) and RYn2 (Reverse rotation start) stops the operation.

2. POINT TABLE OPERATION

(4) Timing chart

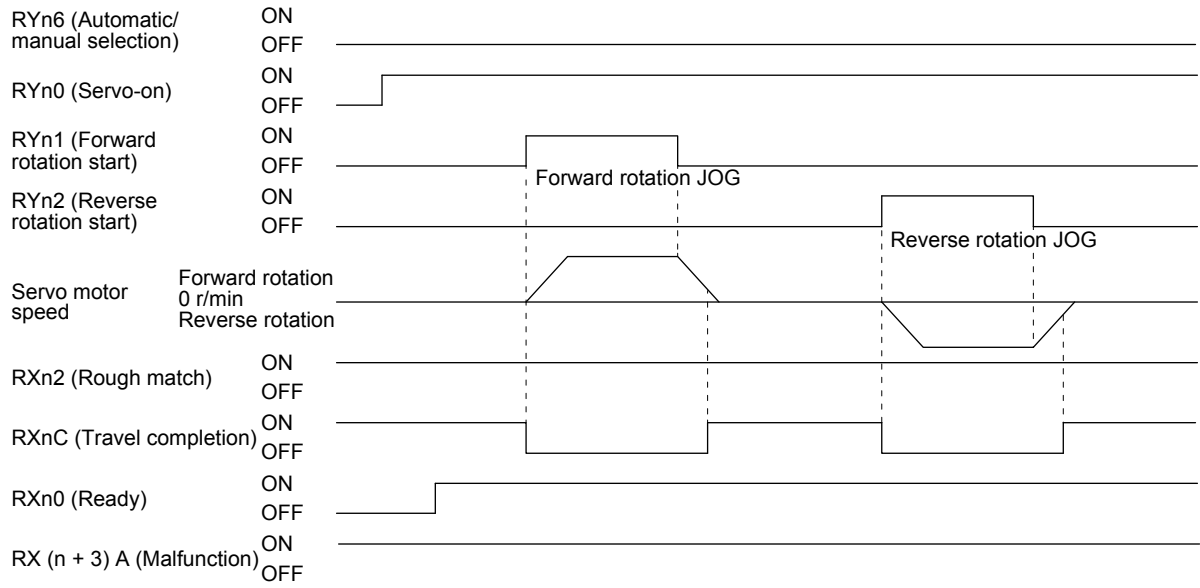

2. POINT TABLE OPERATION

(5) Temporary stop/restart

When RYn7 (Temporary stop/restart) is switched on during JOG operation, the servo motor decelerates with the deceleration time constant being executed ([Pr. PT50]), and then stops temporarily. Turning on RYn7 (Temporary stop/restart) again restarts the JOG operation. However, if both RYn1 (Forward rotation start) and RYn2 (Reverse rotation start) are on or off, the operation does not restart.

During a temporary stop, RYn1 (Forward rotation start) or RYn2 (Reverse rotation start) does not function even if it is switched on.

When any of the following conditions is satisfied during a temporary stop, the temporary stop is reset.

- The manual operation mode is switched to the automatic operation mode.
- The servo motor enters the servo-off status.
- The stroke limit or software limit is detected.
- The controller is reset.

The temporary stop/restart input functions in the following status.

Operation status	Automatic operation	Manual operation	Home position return
During a stop		Pause	Pause
During acceleration	Pause	Pause	Pause
At a constant speed	Pause	Pause	Pause
Deceleration		Pause	Pause
During a temporary stop	Restart	Restart	Stop

(a) When the servo motor is rotating

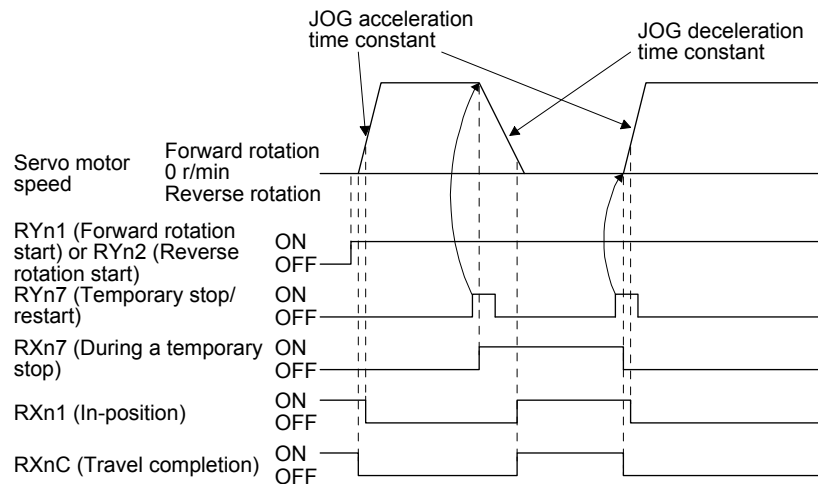

2. POINT TABLE OPERATION

(b) When the servo motor has been restarted during a temporary stop

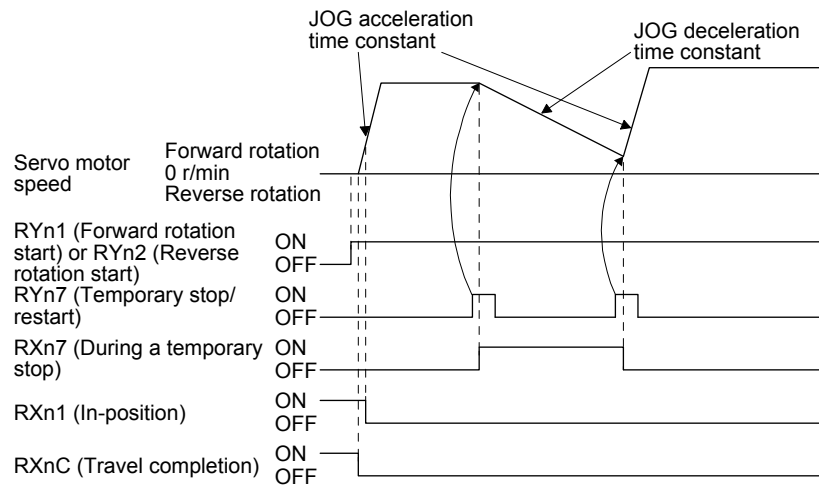

2. POINT TABLE OPERATION

2.5 Home position return mode

POINT
<ul style="list-style-type: none">● Before performing the home position return, make sure that the limit switch operates.● Check the home position return direction. An incorrect setting will cause a reverse running.● Check the input polarity of the proximity dog. Otherwise, it may cause an unexpected operation.● In the following cases, make sure that the Z-phase has been passed through once before performing a home position return.<ul style="list-style-type: none">▪ When using an incremental linear encoder in the linear servo motor control mode▪ When using an incremental external encoder in the fully closed loop control mode▪ For the use in the DD motor control modeZ-phase unpassed will trigger [AL. 90.5 Home position return incomplete warning].● To execute a home position return securely, start a home position return after moving the linear servo motor to the opposite stroke end.

2. POINT TABLE OPERATION

2.5.1 Outline of home position return

A home position return is performed to match the command coordinates with the machine coordinates. Under the incremental method, each power-on of the input power supply requires the home position return. Contrastingly, in the absolute position detection system, once you have performed the home position return at machine installation, the current position will be retained even if the power supply is shut off. Therefore, the home position return is unnecessary when the power supply is switched on again.

This section shows the home position return types of the servo amplifier. Select the optimum method according to the configuration and uses of the machine.

When a home position return is started with the controller, Controlword bit4 will turn on. For details of the home position return, refer to the controller instruction manual.

(1) Home position return types

POINT
<ul style="list-style-type: none"> ● For the home position return types for which "Motion mode" is described in the detailed explanation field, refer to section 4.6 of "MR-J4-_GF_(-RJ) Servo Amplifier Instruction Manual (Motion Mode)". In addition, replace the following left signals to the right signals. <ul style="list-style-type: none"> ▪ Statusword bit 10 Target reached → RXnC (Travel completion) ▪ Statusword bit 12 Homing attained → RX (n+1) 0 (Home position return completion 2) ▪ Controlword bit 4 Homing operation start → RYn1 (Forward rotation start) ▪ DOG (Proximity dog) → RYn3 (Proximity dog) ▪ TLC (Limiting torque) → RXn4 (Limiting torque)

Select the optimum home position return type according to the machine type or others.

Method No.	Home position return type	Rotation direction	Description	Detailed explanation
-1	Dog type (Rear end detection, Z-phase reference)	Forward rotation	Deceleration starts at the front end of the proximity dog. After the rear end is passed, the position specified by the first Z-phase signal, or the position of the first Z-phase signal shifted by the specified home position shift distance is used as the home position.	Motion mode
-33		Reverse rotation		
-4	Stopper type (Stopper position reference)	Forward rotation	A workpiece is pressed against a mechanical stopper, and the position where it is stopped is set as the home position.	
-36		Reverse rotation		
-2	Count type (Front end detection, Z-phase reference)	Forward rotation	At the front end of the proximity dog, deceleration starts. After the front end is passed, the position specified by the first Z-phase signal after the set distance or the position of the Z-phase signal shifted by the set home position shift distance is set as a home position.	
-34		Reverse rotation		
-5	Home position ignorance (Servo-on position as home position)	/	Servo-on position is set as the home position.	Section 2.5.2
-6	Dog type (Rear end detection, rear end reference)	Forward rotation	Deceleration starts from the front end of the proximity dog. After the rear end is passed, the position is shifted by the travel distance after proximity dog and the home position shift distance. The position after the shifts is set as the home position.	Motion mode
-38		Reverse rotation		

2. POINT TABLE OPERATION

Method No.	Home position return type	Rotation direction	Description	Detailed explanation
-7	Count type (Front end detection, front end reference)	Forward rotation	Deceleration starts from the front end of the proximity dog. The position is shifted by the travel distance after proximity dog and the home position shift distance. The position after the shifts is set as the home position.	Motion mode
-39		Reverse rotation		
-8	Dog cradle type	Forward rotation	A position, which is specified by the first Z-phase signal after the front end of the proximity dog is detected, is set as the home position.	
-40		Reverse rotation		
-9	Dog type last Z-phase reference	Forward rotation	After the front end of the proximity dog is detected, the position is shifted away from the proximity dog in the reverse direction. Then, the position specified by the first Z-phase signal or the position of the first Z-phase signal shifted by the home position shift distance is used as the home position.	
-41		Reverse rotation		
-10	Dog type front end reference	Forward rotation	Starting from the front end of the proximity dog, the position is shifted by the travel distance after proximity dog and the home position shift distance. The position after the shifts is set as the home position.	
-42		Reverse rotation		
-11	Dogless Z-phase reference	Forward rotation	The position specified by the first Z-phase signal, or the position of the first Z-phase signal shifted by the home position shift distance is used as the home position.	
-43		Reverse rotation		
3	Homing on positive home switch and index pulse	Forward rotation	Same as the dog type last Z-phase reference home position return. Note that if the stroke end is detected during home position return, [AL. 90 Home position return incomplete warning] occurs.	
4	Homing on positive home switch and index pulse	Forward rotation	Same as the dog cradle type home position return. Note that if the stroke end is detected during home position return, [AL. 90 Home position return incomplete warning] occurs.	
5	Homing on negative home switch and index pulse	Reverse rotation	Same as the dog type last Z-phase reference home position return. Note that if the stroke end is detected during home position return, [AL. 90 Home position return incomplete warning] occurs.	
6	Homing on negative home switch and index pulse	Reverse rotation	Same as the dog cradle type home position return. Note that if the stroke end is detected during home position return, [AL. 90 Home position return incomplete warning] occurs.	
7	Homing on home switch and index pulse	Forward rotation	Same as the dog type last Z-phase reference home position return.	
8	Homing on home switch and index pulse	Forward rotation	Same as the dog cradle type home position return.	
11	Homing on home switch and index pulse	Reverse rotation	Same as the dog type last Z-phase reference home position return.	
12	Homing on home switch and index pulse	Reverse rotation	Same as the dog cradle type home position return.	
19	Homing without index pulse	Forward rotation	Same as the dog type front end reference home position return. Note that if the stroke end is detected during home position return, [AL. 90 Home position return incomplete warning] occurs.	
20	Homing without index pulse	Forward rotation	Although this type is the same as the dog cradle type home position return, the stop position is not on the Z-phase. Starting from the front end of the dog, the position is shifted by the travel distance after proximity dog and the home position shift distance. The position after the shifts is set as the home position. If the stroke end is detected during home position return, [AL. 90 Home position return incomplete warning] occurs.	

2. POINT TABLE OPERATION

Method No.	Home position return type	Rotation direction	Description	Detailed explanation
21	Homing without index pulse	Reverse rotation	Same as the dog type front end reference home position return. Note that if the stroke end is detected during home position return, [AL. 90 Home position return incomplete warning] occurs.	Motion mode
22	Homing without index pulse	Reverse rotation	Although this type is the same as the dog cradle type home position return, the stop position is not on the Z-phase. Starting from the front end of the dog, the position is shifted by the travel distance after proximity dog and the home position shift distance. The position after the shifts is set as the home position. If the stroke end is detected during home position return, [AL. 90 Home position return incomplete warning] occurs.	
23	Homing without index pulse	Forward rotation	Same as the dog type front end reference home position return.	
24	Homing without index pulse	Forward rotation	Although this type is the same as the dog cradle type home position return, the stop position is not on the Z-phase. Starting from the front end of the dog, the position is shifted by the travel distance after proximity dog and the home position shift distance. The position after the shifts is set as the home position.	
27	Homing without index pulse	Reverse rotation	Same as the dog type front end reference home position return.	
28	Homing without index pulse	Reverse rotation	Although this type is the same as the dog cradle type home position return, the stop position is not on the Z-phase. Starting from the front end of the dog, the position is shifted by the travel distance after proximity dog and the home position shift distance. The position after the shifts is set as the home position.	
33	Homing on index pulse	Reverse rotation	Although this type is the same as the dogless Z-phase reference home position return, the creep speed is applied as the movement start speed.	
34	Homing on index pulse	Forward rotation	Although this type is the same as the dogless Z-phase reference home position return, the creep speed is applied as the movement start speed.	
35	Homing on current position		The current position is set as the home position. This type can be executed not in the Operational enabled state.	
37	Homing on current position		The current position is set as the home position. This type can be executed not in the Operational enabled state.	

2. POINT TABLE OPERATION

(2) Parameters for home position return

To perform the home position return, set each parameter as follows.

- (a) Select the home position return type and home position return direction with [Pr. PT45 Home position return type].

Setting value	Home position return direction	Home position return type
-1	Address increasing direction	Dog type (rear end detection, Z-phase reference)
-2		Count type (front end detection, Z-phase reference)
-4		Stopper type (stopper position reference)
-5		Home position ignorance (Servo-on position as home position)
-6		Dog type (rear end detection, rear end reference)
-7		Count type (front end detection, front end reference)
-8		Dog cradle type
-9		Dog type last Z-phase reference
-10		Dog type front end reference
-11		Dogless Z-phase reference
-33		Address decreasing direction
-34	Count type (front end detection, Z-phase reference)	
-36	Stopper type (stopper position reference)	
-38	Dog type (rear end detection, rear end reference)	
-39	Count type (front end detection, front end reference)	
-40	Dog cradle type	
-41	Dog type last Z-phase reference	
-42	Dog type front end reference	
-43	Dogless Z-phase reference	

Setting value	Home position return direction	Home position return type
3	Address increasing direction	Method 3
4		Method 4
5	Address decreasing direction	Method 5
6		Method 6
7	Address increasing direction	Method 7
8		Method 8
11	Address decreasing direction	Method 11
12		Method 12
19	Address increasing direction	Method 19
20		Method 20
21	Address decreasing direction	Method 21
22		Method 22
23	Address increasing direction	Method 23
24		Method 24
27	Address decreasing direction	Method 27
28		Method 28
33		Method 33
34	Address increasing direction	Method 34
35		Method 35
37		Method 37 (Data set type)

2. POINT TABLE OPERATION

- (b) Select the polarity where the proximity dog is detected with the DOG (Proximity dog) polarity selection of [Pr. PT29 Function selection T-3].
Setting "0" detects a proximity dog when RYn3 (Proximity dog) is switched off. Setting "1" detects a proximity dog when RYn3 (Proximity dog) is switched on.

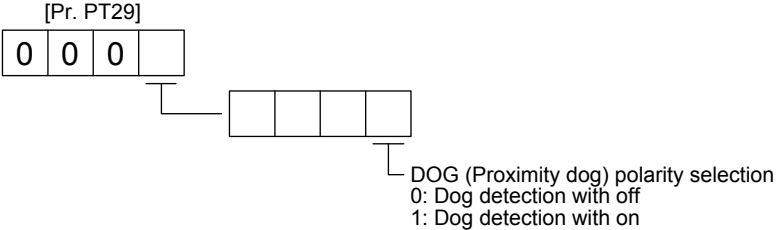

2. POINT TABLE OPERATION

(3) Temporary stop/restart

When RYn7 (Temporary stop/restart) is switched on during home position return, the servo motor decelerates with the home position return deceleration time constant being executed ([Pr. PT56] or [Pr. PT57]), and then stops temporarily. Turning on RYn7 (Temporary stop/restart) again resets the temporary stop, but the operation does not restart. Turning on RYn1 (Forward rotation start) after the temporary stop is reset restarts the home position return.

During a temporary stop, RYn1 (Forward rotation start) or RYn2 (Reverse rotation start) does not function even if it is switched on.

When any of the following conditions is satisfied during a temporary stop, the temporary stop is reset.

- The home position return mode is switched to the automatic operation mode or manual operation mode.
- The servo motor enters the servo-off status.
- The stroke limit or software limit is detected.
- The controller is reset.

The temporary stop/restart input functions in the following status.

Operation status	Automatic operation	Manual operation	Home position return
During a stop		Pause	Pause
During acceleration	Pause	Pause	Pause
At a constant speed	Pause	Pause	Pause
Deceleration		Pause	Pause
During a temporary stop	Restart	Restart	Stop

When the home position return is being executed

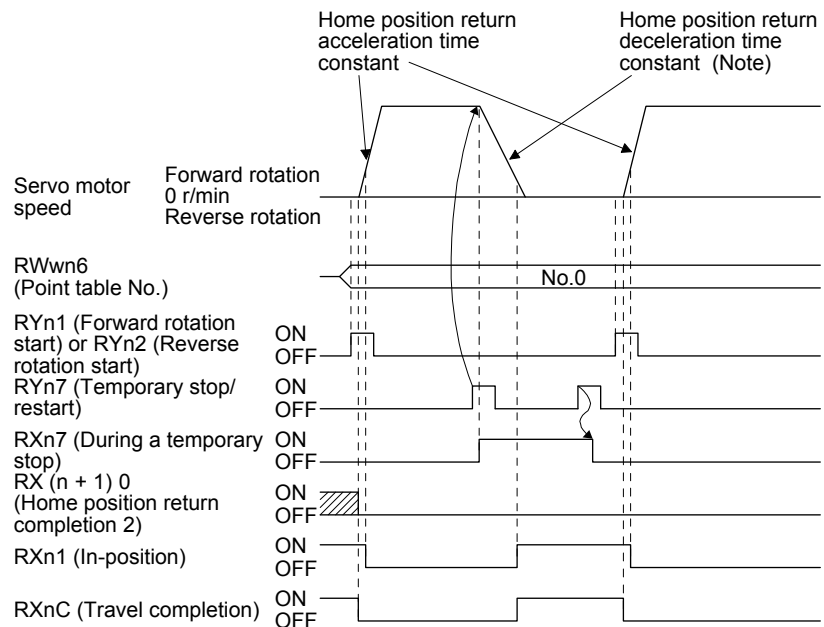

Note. Select the deceleration time constant from [Pr. PT56] and [Pr. PT57] using the setting value of [Pr. PT55].

2. POINT TABLE OPERATION

2.5.2 Method -5 (Home position ignorance (Servo-on position as home position))

POINT
<p>● When you perform this home position return, it is unnecessary to switch to the home position return mode.</p>

The position at servo-on is used as the home position.

(1) Timing chart

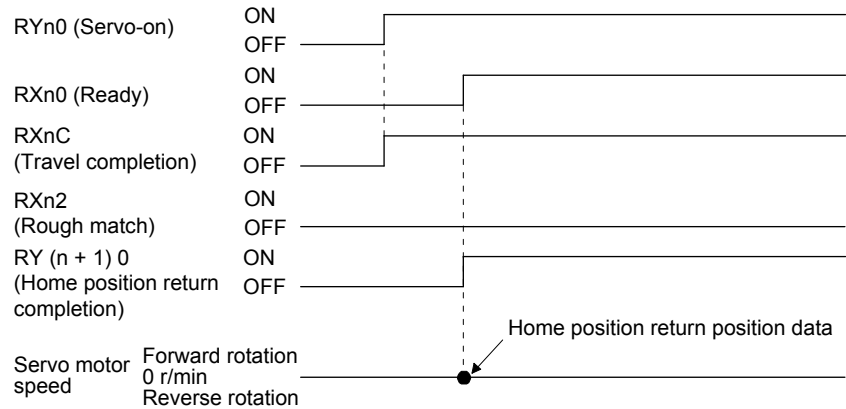

The setting value of [Pr. PT08 Home position return position data] is used as the position address at the home position return completion.

2. POINT TABLE OPERATION

2.5.3 Automatic positioning to home position function

POINT
<p>● The automatic positioning to the home position cannot be performed from outside the setting range of position data. In this case, perform the home position return again using the home position return.</p>

After power-on, if the home position return is performed again after the home position return is performed to define the home position, this function enables automatic positioning to the home position rapidly. For the absolute position detection system, the home position return is unnecessary after the power-on.

When the automatic positioning to the home position is performed at home position return incompleteness, [AL. 90.1] will occur.

After the power-on, perform the home position return in advance.

Set link devices and parameters as follows:

Item	Used device/parameter	Setting
Home position return mode selection	RYn6 (Automatic/manual selection)	Switch on RYn6.
	RWwn6 (Point table No. selection)	Set "0" in RWwn6.
Home position return speed	[Pr. PT05]	Set the servo motor speed to travel to the home position.
Home position return acceleration/deceleration time constant	Acceleration time constant: [Pr. PT56] Deceleration time constant: [Pr. PT56] (When "___ 0" is set in [Pr. PT55]) [Pr. PT57] (When "___ 1" is set in [Pr. PT55])	Set an acceleration time constant and deceleration time constant.

Set the home position return speed of the automatic positioning to home position function with [Pr. PT05]. Set the acceleration time constant with [Pr. PT56]. Select the deceleration time constant from [Pr. PT56] and [Pr. PT57] using the setting value of [Pr. PT55]. Turning on RYn2 (Reverse rotation start) executes the automatic return function to the home position.

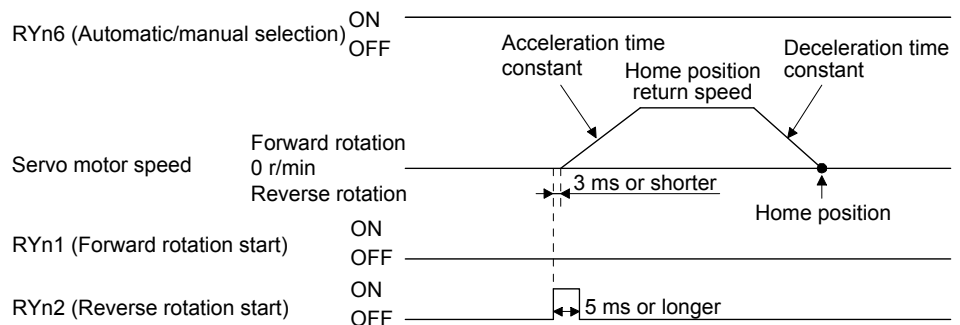

2. POINT TABLE OPERATION

2.6 Point table setting method

The following shows the setting method of point tables using MR Configurator2.

2.6.1 Setting procedure

Click "Positioning-data" in the menu bar and click "Point Table" in the menu.

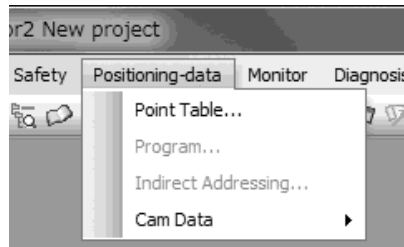

The following window will be displayed by clicking.

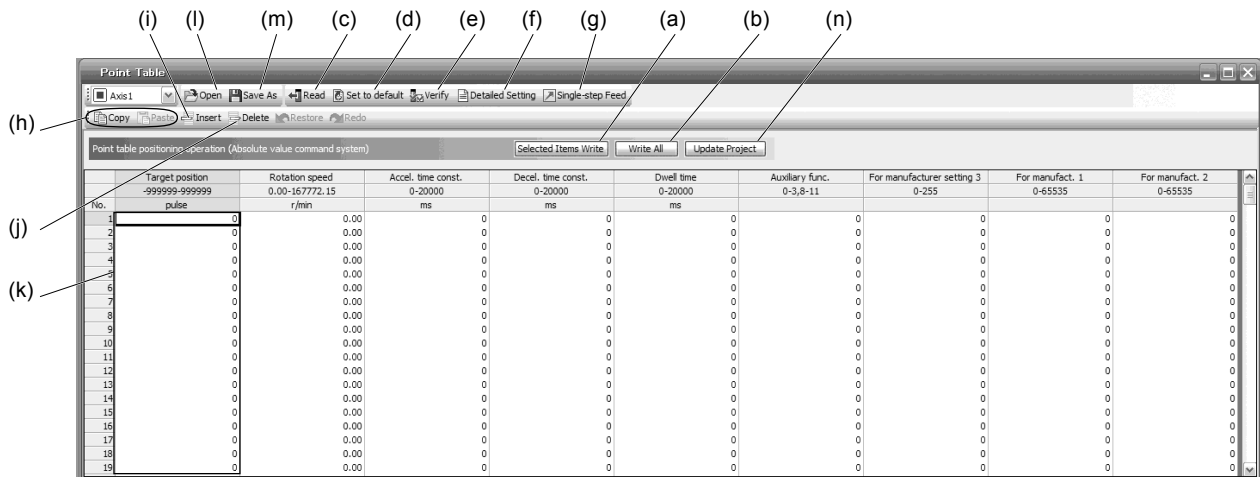

(1) Writing point table data (a)

Select changed point table data and click "Selected Items Write" to write the changed point table data to the servo amplifier.

(2) Writing all point table data (b)

Click "Write All" to write all the point table data to the servo amplifier.

(3) Reading all point table data (c)

Click "Read" to read and display all the point table data from the servo amplifier.

(4) Initial setting of point table data (d)

Click "Set to default" to initialize all the data of point table No. 1 to 255. This function also initializes data currently being edited.

2. POINT TABLE OPERATION

- (5) Verifying point table data (e)
Click "Verify" to verify all the data displayed and data of the servo amplifier.
- (6) Detailed setting of point table data (f)
Click "Detailed Setting" to change position data range and unit in the point table window. Refer to section 2.6.2 for details.
- (7) Single-step feed (g)
Click "Single-step Feed" to perform the single-step feed test operation. Refer to section 2.6.3 for details.
- (8) Copy and paste of point table data (h)
Click "Copy" to copy the selected point table data. Click "Paste" to paste the copied point table data.
- (9) Inserting point table data (i)
Click "Insert" to insert a block to the previous row from the selected point table No. The selected point table No. and lower rows will be shifted down one by one.
- (10) Deleting point table data (j)
Click "Delete" to delete all the data of the point table No. selected. The lower rows of the selected point table No. will be shifted up one by one.
- (11) Changing point table data (k)
After selecting the data to be changed, enter a new value, and click "Enter". You can change the displayed range and unit with "(6) Detailed setting of point table data" of this section.
- (12) Reading point table data (l)
Click "Open" to read the point table data.
- (13) Saving point table data (m)
Click "Save As" to save the point table data.
- (14) Updating project (n)
Click "Update Project" to update the point table data to a project.

2. POINT TABLE OPERATION

2.6.2 Detailed setting window

You can change position data range and unit with the detailed setting for the point table window. For the position data range and unit of [Pr. PT01] setting, refer to section 2.3.2. To reflect the setting for the corresponding parameter, click "Update Project" in the point table window.

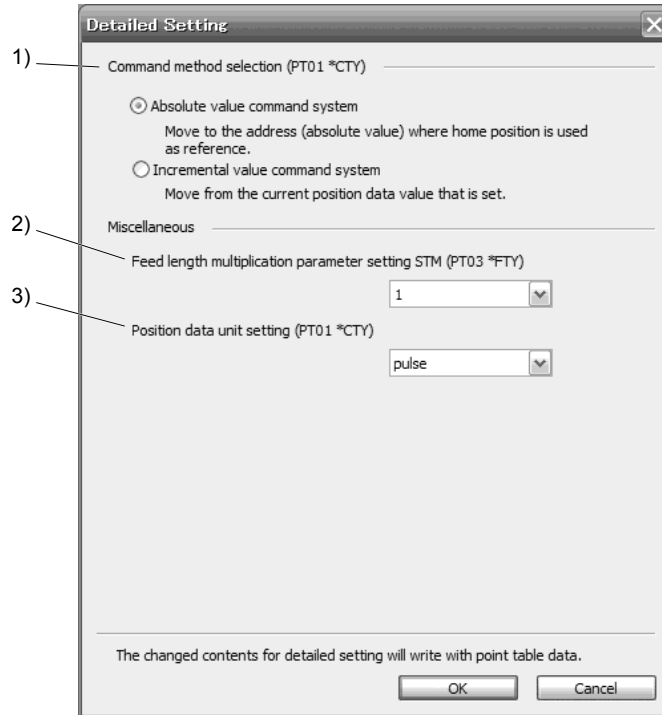

- (1) Command method selection (PT01 *CTY) 1)
Select a positioning command method from the absolute position command method and incremental value command method.
- (2) Miscellaneous
 - (a) Feed length multiplication parameter setting STM (PT03 *FTY) 2)
Select any feed length multiplication from 1/10/100/1000.
 - (b) Position data unit setting (PT01 *CTY) 3)
Select any unit of position data from mm/inch/degree/pulse. While degree or pulse is selected, setting of feed length multiplication will be disabled.

2. POINT TABLE OPERATION

2.6.3 Single-step feed



CAUTION

- The test operation mode is designed for checking servo operation. Do not use it for actual operation.
- If the servo motor operates unexpectedly, use EM2 (Forced stop 2) to stop it.

POINT

- MR Configurator2 is required to perform single-step feed.
- Test operation cannot be performed if RYn0 (Servo-on) is not turned off.

The positioning operation can be performed in accordance with the point table No. set by MR Configurator2. Select the test operation/single-step feed by the menu of MR Configurator2. When the single-step feed window is displayed, input the following items and operate.

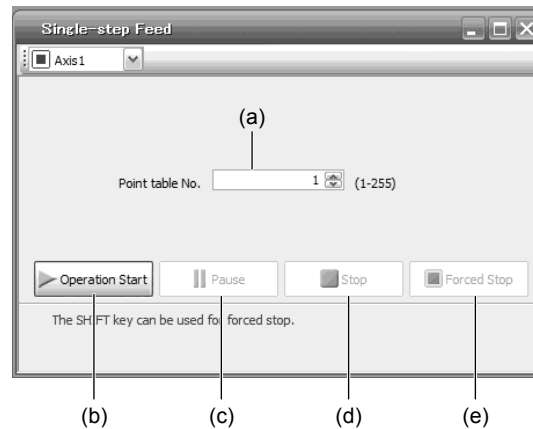

Point table operation

- (1) Point table No. setting
Input a point table No. into the input box (a) "Point table No."
- (2) Forward/reverse the servo motor
Click "Operation Start" (b) to rotate the servo motor.
- (3) Pause the servo motor
Click "Pause" (c) to temporarily stop the servo motor.
While the servo motor is temporarily stopped, click "Operation Start" (b) to restart the rotation by the amount of the remaining travel distance.
While the servo motor is temporarily stopped, click "Stop" (d) to clear the remaining travel distance.
- (4) Stop the servo motor
Click "Stop" (d) to stop the servo motor. At this time, the remaining travel distance is cleared. Click "Operation Start" (b) to restart the rotation.
- (5) Forced stop of the servo motor software
Click "Forced Stop" (e) to make an instantaneous stop. When "Forced Stop" is enabled, "Operation Start" cannot be used. Click the "Forced Stop" again to enable the "Operation Start".
- (6) Switch to the normal operation mode
Before switching from the test operation mode to the normal operation mode, turn off the servo amplifier.

2. POINT TABLE OPERATION

2.7 Programming example by function

This section explains specific programming examples for operating or monitoring the servo and for reading or writing parameters based on the device configuration shown in section 2.7.1.

2.7.1 System configuration example

As shown below, a CC-Link IE Field Network master/local module is mounted to operate two servo amplifiers.

(1) System configuration

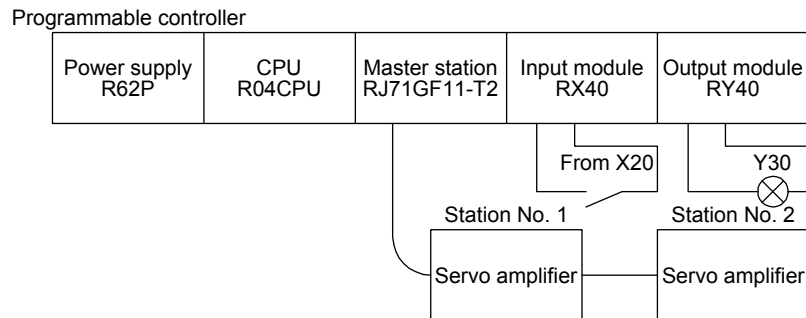

(2) Network parameter setting in the master station

In the programming examples, the network parameters are set as follows:

Item	Setting condition	
Start I/O No.	0000	
Operation setting	Data link error station setting	Clear
	Setting at CPU STOP	Held
Type	Master station	
Mode setting	Standard	
Total No. of connected units	2	
Remote input (RX)	X1000	
Refresh device		
Remote output (RY)	Y1000	
Refresh device		

Item	Setting condition
Remote register (RW _r)	W0
Refresh device	
Remote register (RW _w)	W100
Refresh device	
Special relay (SB)	SB0
Refresh device	
Special register (SW)	SW0
Refresh device	
CPU down specification	Clear
Scan mode specification	Asynchronous sequence scan

2. POINT TABLE OPERATION

(3) Assignment of remote inputs/outputs (RX, RY)

The following shows the assignment of remote inputs/outputs (RX, RY) of the station to the devices of the programmable controller CPU.

The devices actually used are shaded.

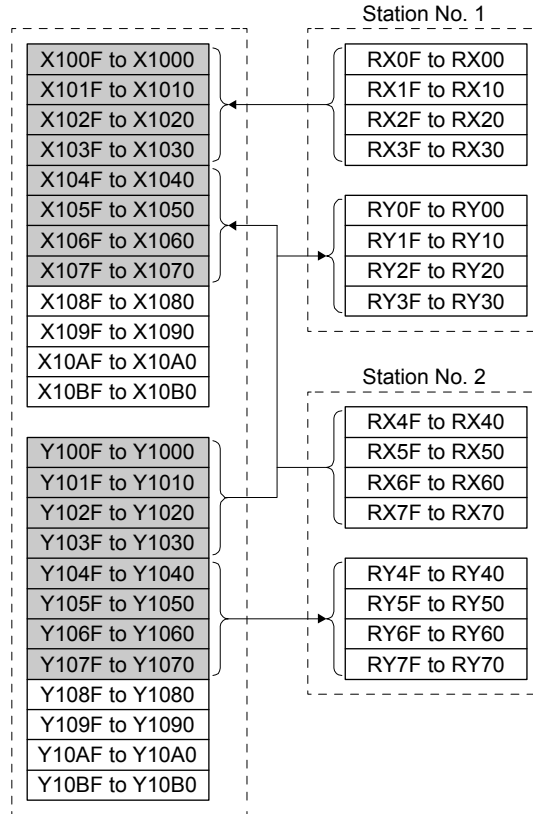

2. POINT TABLE OPERATION

(4) Assignment of remote registers (RWw, RWr)

The following shows the assignment of remote registers (RWw, RWr) of the station to the devices of the programmable controller CPU.

The devices actually used are shaded.

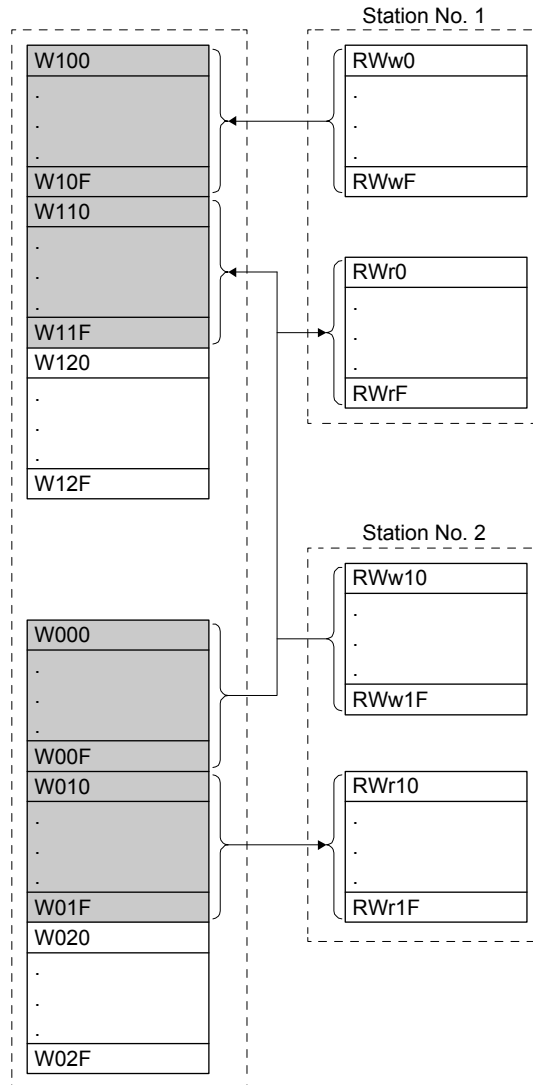

2. POINT TABLE OPERATION

2.7.2 Reading the servo amplifier status

When the servo amplifier with station No. 1 enters remote station communication ready, the output module Y30 turns on.

This program turns on Y30 when the CC-Link IE Field Network communication is normally established.

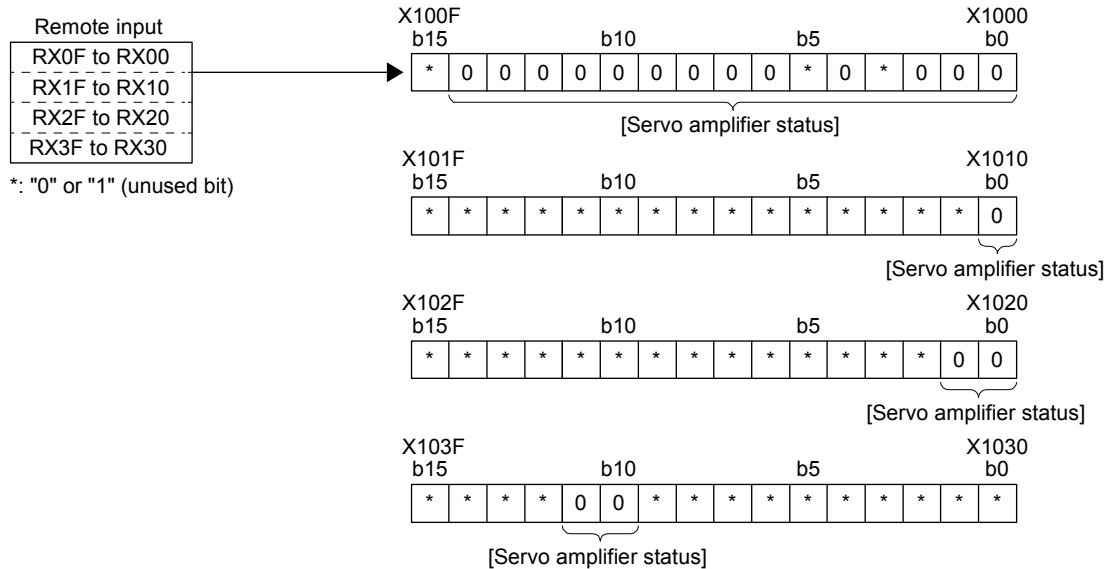
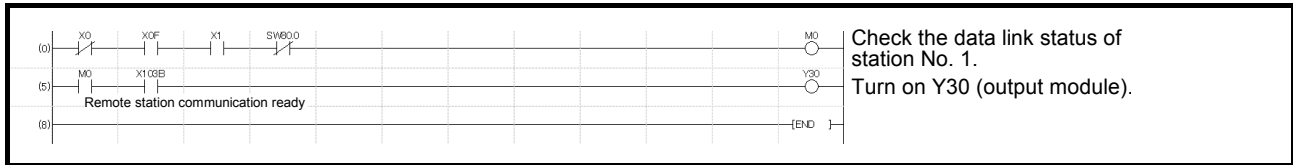

Servo amplifier status		
X1000: RD (Ready)	X1016: ---	X102C: ---
X1001: INP (In-position)	X1017: ---	X102D: ---
X1002: CPO (Rough match)	X1018: ---	X102E: ---
X1003: ---	X1019: ---	X102F: ---
X1004: TLC (Limiting torque)	X101A: ---	X1030: ---
X1005: ---	X101B: ---	X1031: ---
X1006: MBR (Electromagnetic brake interlock)	X101C: ---	X1032: ---
X1007: PUS (Temporary stop)	X101D: ---	X1033: ---
X1008: MOF (Monitoring)	X101E: ---	X1034: ---
X1009: COF (Instruction code execution completion)	X101F: ---	X1035: ---
X100A: WNG (Warning)	X1020: PSF (Position instruction execution completion)	X1036: ---
X100B: BWNG (Battery warning)	X1021: SPF (Speed instruction execution completion)	X1037: ---
X100C: MEND (Travel completion)	X1022: ---	X1038: ---
X100D: DB (Dynamic brake interlock)	X1023: ---	X1039: ---
X100E: POT (Position range)	X1024: ---	X103A: ALM (Malfunction)
X100F: ---	X1025: ---	X103B: CRD (Remote station communication ready)
X1010: ZP2 (Home position return completion 2)	X1026: ---	X103C: ---
X1011: ---	X1027: ---	X103D: ---
X1012: ---	X1028: ---	X103E: ---
X1013: ---	X1029: ---	X103F: ---
X1014: ---	X102A: ---	
X1015: ---	X102B: ---	

2. POINT TABLE OPERATION

2.7.3 Writing an operation command

The servo amplifier with station No. 1 performs positioning operation according to point table No. 2. Turning on X20 starts the operation.

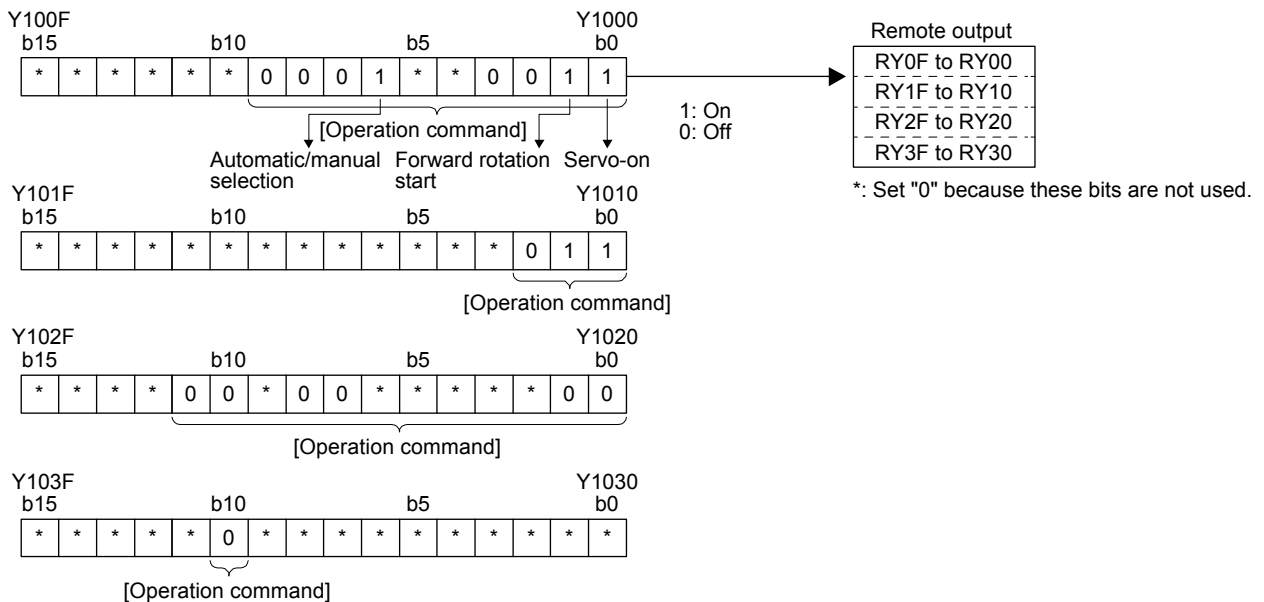
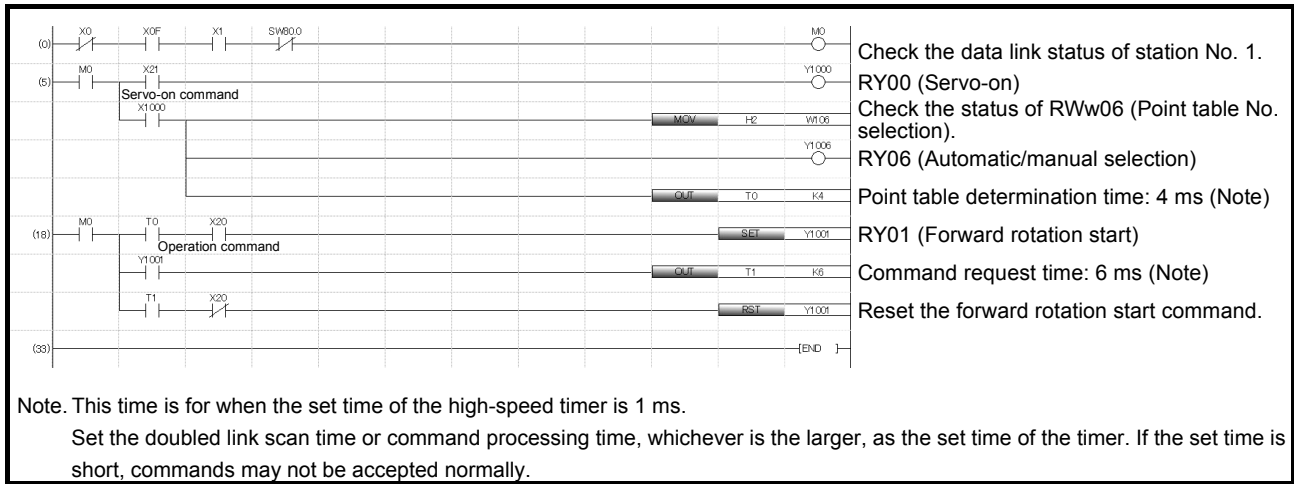

2. POINT TABLE OPERATION

Operation command		
Y1000: SON (Servo-on)	Y1016: ---	Y102C: ---
Y1001: ST1 (Forward rotation start)	Y1017: ---	Y102D: ---
Y1002: ST2 (Reverse rotation start)	Y1018: ---	Y102E: ---
Y1003: DOG (Proximity dog)	Y1019: ---	Y102F: ---
Y1004: ---	Y101A: ---	Y1030: ---
Y1005: ---	Y101B: ---	Y1031: ---
Y1006: MD0 (Automatic/manual selection)	Y101C: ---	Y1032: ---
Y1007: TSTP (Temporary stop/restart)	Y101D: ---	Y1033: ---
Y1008: MOR (Monitor output execution demand)	Y101E: ---	Y1034: ---
Y1009: COR (Instruction code execution demand)	Y101F: ---	Y1035: ---
Y100A: ---	Y1020: PSR (Position command execution demand)	Y1036: ---
Y100B: ---	Y1021: SPR (Speed command execution demand)	Y1037: ---
Y100C: ---	Y1022: ---	Y1038: ---
Y100D: ---	Y1023: ---	Y1039: ---
Y100E: ---	Y1024: ---	Y103A: RES (Reset)
Y100F: ---	Y1025: ---	Y103B: ---
Y1010: FLS (Upper stroke limit)	Y1026: ---	Y103C: ---
Y1011: RLS (Lower stroke limit)	Y1027: PC (Proportional control)	Y103D: ---
Y1012: ORST (Operation alarm reset)	Y1028: CDP (Gain switching)	Y103E: ---
Y1013: ---	Y1029: ---	Y103F: ---
Y1014: ---	Y102A: CSL (Position/speed specifying method selection)	
Y1015: ---	Y102B: CAOR (Absolute value/incremental value selection)	

2. POINT TABLE OPERATION

2.7.4 Reading data

Data of the servo amplifier is read.

(1) Reading monitor

The cumulative feedback pulses of the servo amplifier with station No. 2 are read to D10.

Code No.	Description
H000A	Cumulative feedback pulse data (hexadecimal)

Turning on X20 reads the monitor of the cumulative feedback pulses.

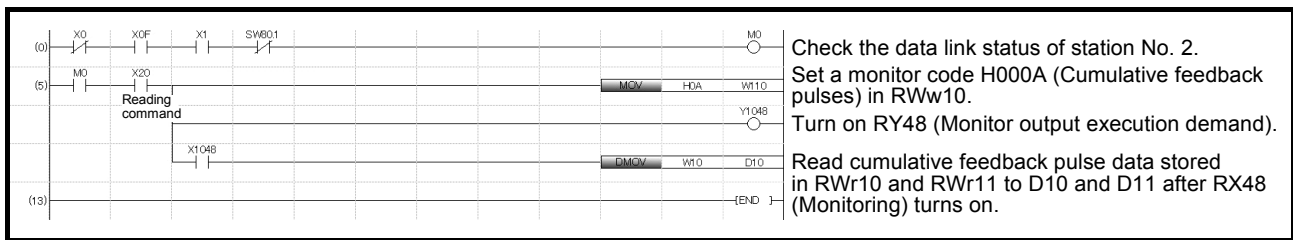

(2) Reading parameters

[Pr. PA04 Function selection A-1] of the servo amplifier with station No. 2 is read to D1.

Code No.	Description
H8200	Select the parameter group.
H0204	Setting value in [Pr. PA04] (hexadecimal)

Turning on X20 reads [Pr. PA04].

A respond code at the execution of the instruction code is set in D3.

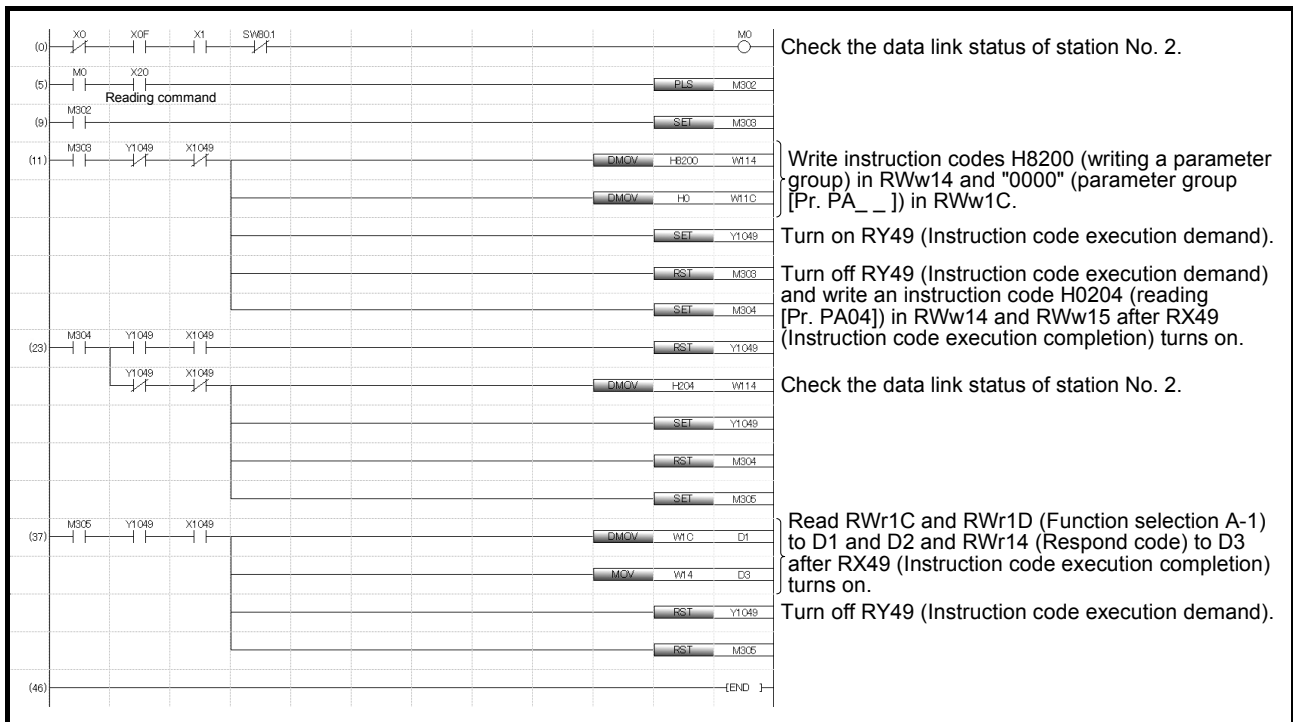

2. POINT TABLE OPERATION

(3) Reading an error

An error of the servo amplifier with station No. 2 is read to D1.

Code No.	Description
H0010	Alarm or warning that is currently occurring (hexadecimal)

Turning on X20 reads the current alarm.

A respond code at the execution of the instruction code is set in D3.

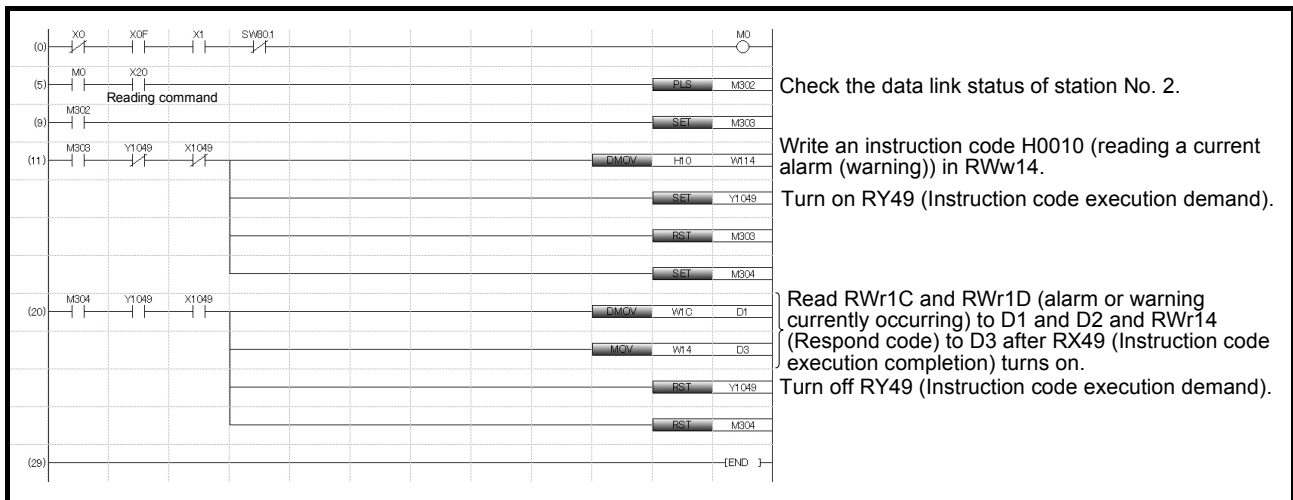

2. POINT TABLE OPERATION

2.7.5 Writing data

This section explains programs for writing data to the servo amplifiers.

(1) Writing servo motor speed data of a point table

The servo motor speed data of point table No. 1 of station No. 2 is changed to "100".

Code No.	Description
H8D01	Write the servo motor speed data of point table No. 1 (hexadecimal).

Setting data	Description
K100	Servo motor speed data of point table No. 1 (decimal)

Turning on X20 writes the servo motor speed data of point table No. 1.

A respond code at the execution of the instruction code is set in D3.

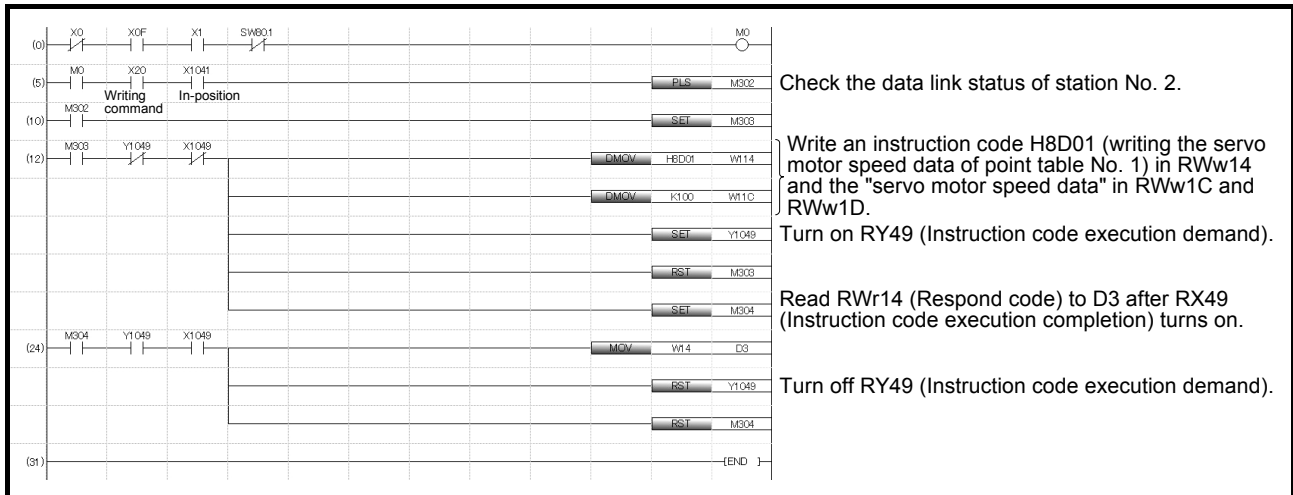

2. POINT TABLE OPERATION

(2) Writing parameters

The parameter [Pr. PT65 JOG speed] of the servo amplifier with station No. 2 is changed to "100". Specify the parameter group PT as follows:

Code No.	Description
H8200	Selecting the parameter group

Setting data	Description
H000C	Setting data (hexadecimal)

The parameter [Pr. PT65] is changed to "100" as follows:

Code No.	Description
H820C	Write [Pr. PT65] (hexadecimal).

Setting data	Description
K100	Setting data (decimal)

Turning on X20 writes [Pr. PT65].

A respond code at the execution of the instruction code is set in D3.

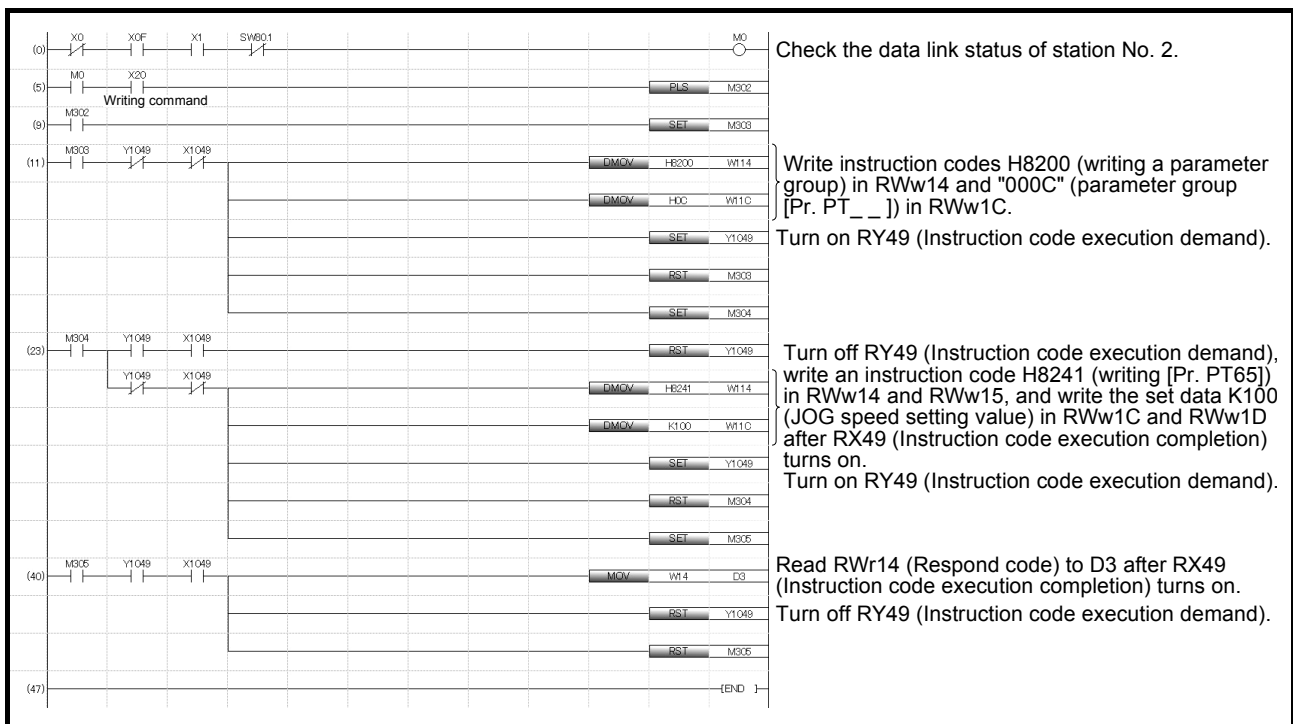

2. POINT TABLE OPERATION

(3) Program example for resetting an alarm of the servo amplifier

- (a) A command from the programmable controller clears an alarm occurring in the servo amplifier with station No. 2.

Turning on X20 clears an alarm occurring in the servo amplifier.

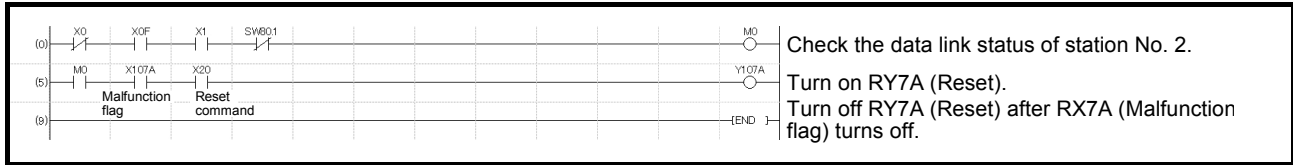

- (b) An instruction code clears an alarm in the servo amplifier with station No. 2.

Code No.	Description
H8010	Alarm reset command (hexadecimal)

Setting data	Description
H1EA5	Execution data (hexadecimal)

Turning on X20 resets the servo amplifier.

A respond code at the execution of the instruction code is set in D3.

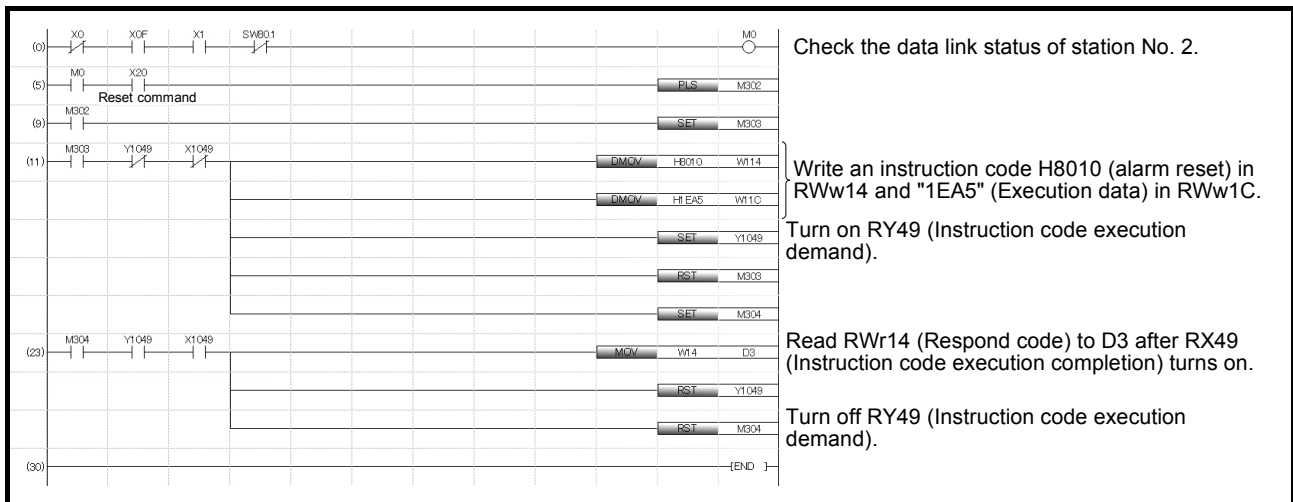

2. POINT TABLE OPERATION

2.7.6 Operation

This section explains programs for operating the servo amplifiers.

(1) JOG operation

The servo amplifier with station No. 1 performs JOG operation and reads the "current position".

Code No.	Description
H0001	Current position data (hexadecimal)

Turning on X22 starts forward rotation JOG operation.

Turning on X23 starts reverse rotation JOG operation.

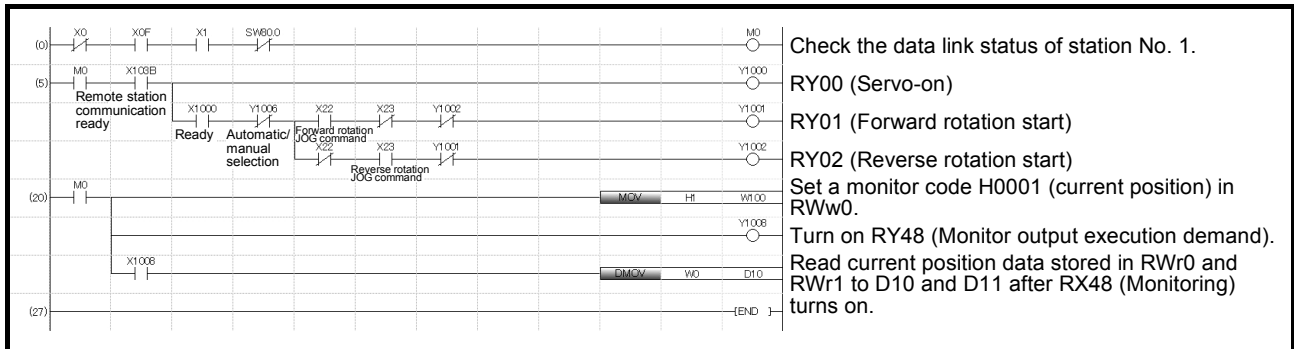

2. POINT TABLE OPERATION

(2) Setting position data and speed data with remote registers

The servo amplifier with station No. 2 is operated with position data of "100000" and speed data of "1000" specified with the direct specification mode.

Set [Pr. PT62] to "___2" in advance.

Setting data	Description
K100000	Position command data (decimal)
K1000	Speed command data (decimal)

Turning on X20 starts positioning operation according to the position and speed settings specified with the remote registers.

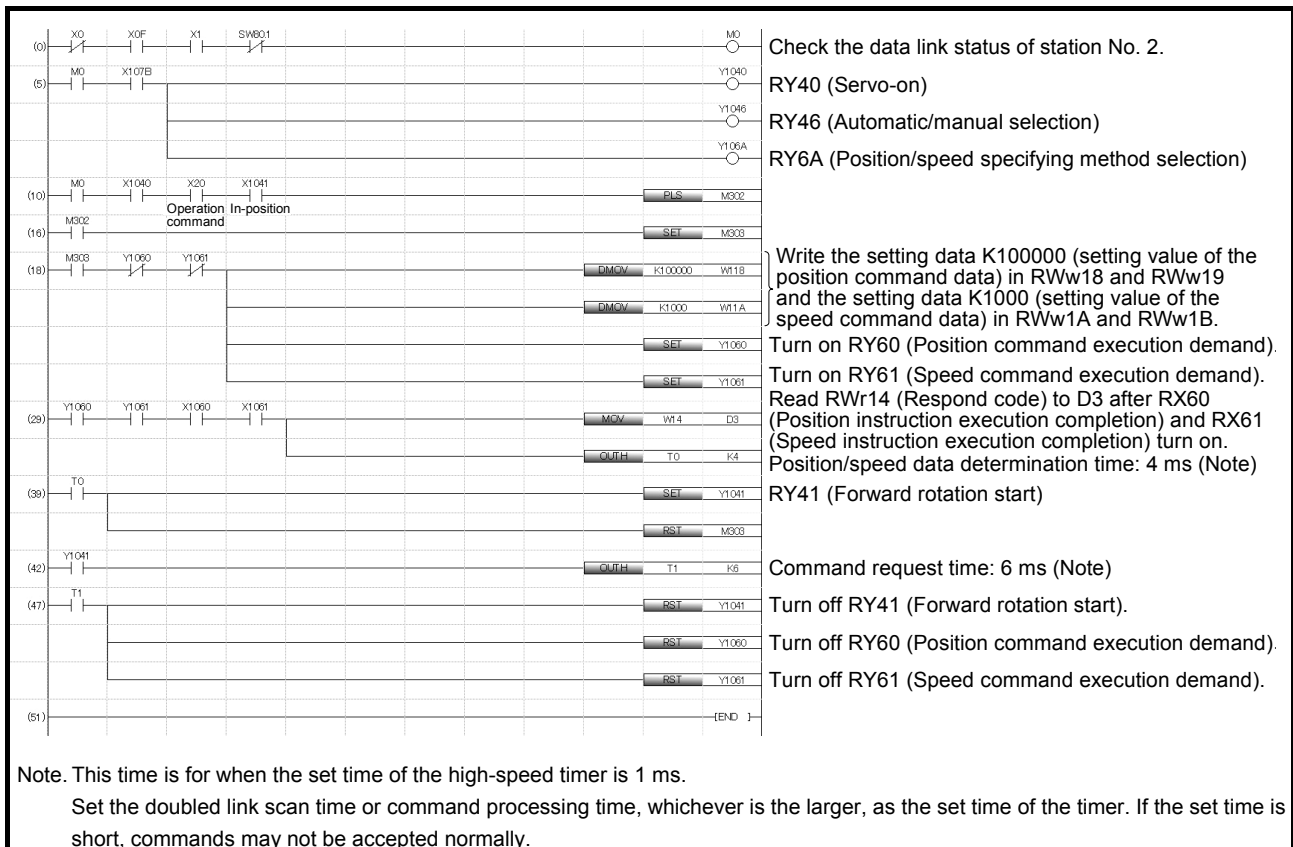

2. POINT TABLE OPERATION

(3) Setting the point table No. with remote registers (incremental value command method)

The servo amplifier with station No. 2 is operated with the incremental value and point table No. 5 specified in the direct specification mode.

Set [Pr. PT62] to "___0" in advance.

Setting data	Description
K5	Point table No. (decimal)

Turning on X20 starts positioning operation according to point table No. 5.

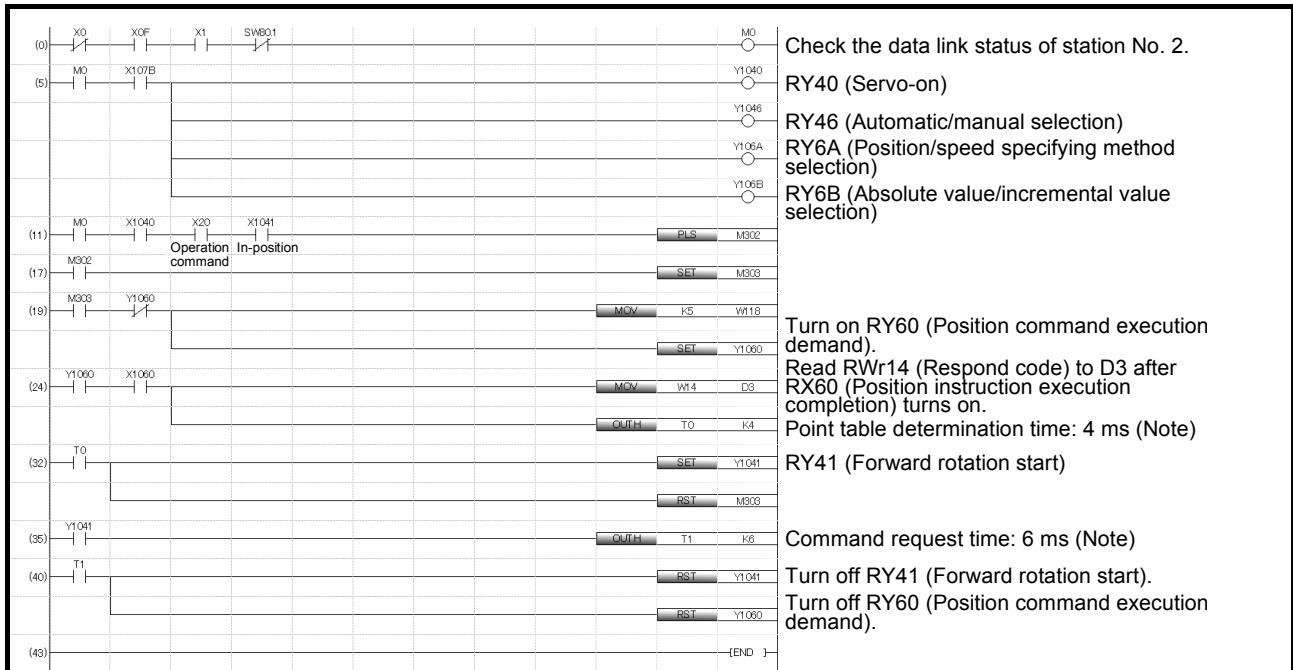

Note. This time is for when the set time of the high-speed timer is 1 ms.

Set the doubled link scan time or command processing time, whichever is the larger, as the set time of the timer. If the set time is short, commands may not be accepted normally.

2. POINT TABLE OPERATION

2.8 Program example for continuous operation

This section shows program examples including operations from servo start-up to a series of CC-Link IE communication. The examples use the following device configuration.

As shown below, a CC-Link system master/local module is mounted to operate one servo amplifier.

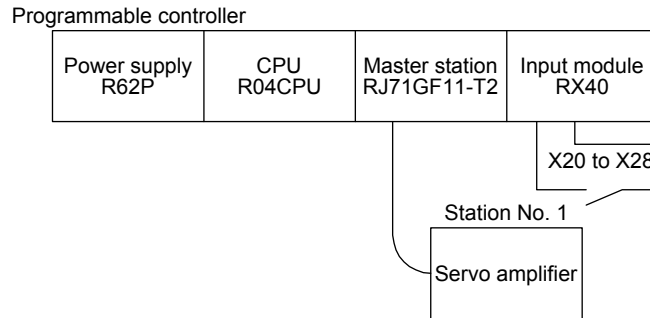

Input signal assignment

Input signal	Signal name	Operation at input ON
X20	Reset command	The servo amplifier is reset when an alarm has occurred.
X21	Servo-on command	The servo-on is activated.
X22	Forward rotation JOG command	When the manual operation mode is set, forward rotation JOG operation is performed.
X23	Reverse rotation JOG command	When the manual operation mode is set, reverse rotation JOG operation is performed.
X24	Automatic/manual selection	Off: Manual operation mode On: Automatic operation mode
X25	Home position return command	When the automatic operation mode is set and home position return has not been completed, the dog type home position return is performed.
X26	Proximity dog command	Off: Proximity dog ON (Note) On: Proximity dog OFF
X27	Position start command	When the automatic operation mode is set and home position return has been completed, positioning operation is performed according to the position and speed settings specified with the remote registers.
X28	Position/speed specifying method switching command	This signal enables the remote register-based position/speed specifying method.

Note. This setting is for when [Pr. PT29] is set to " __ _ 0" (Dog detection with off).

The servo amplifier with station No. 1 performs positioning operation and reads the motor speed data.

Set [Pr. PT62] to " __ _ 2" in advance.

Operation: Alarm reset, dog type home position return, JOG operation, automatic operation with position command data and speed command data

Code No.	Description
H0016	32-bit motor speed data (hexadecimal)

Setting data	Description
K50000	Position command data (decimal)
K100	Speed command data (decimal)

2. POINT TABLE OPERATION

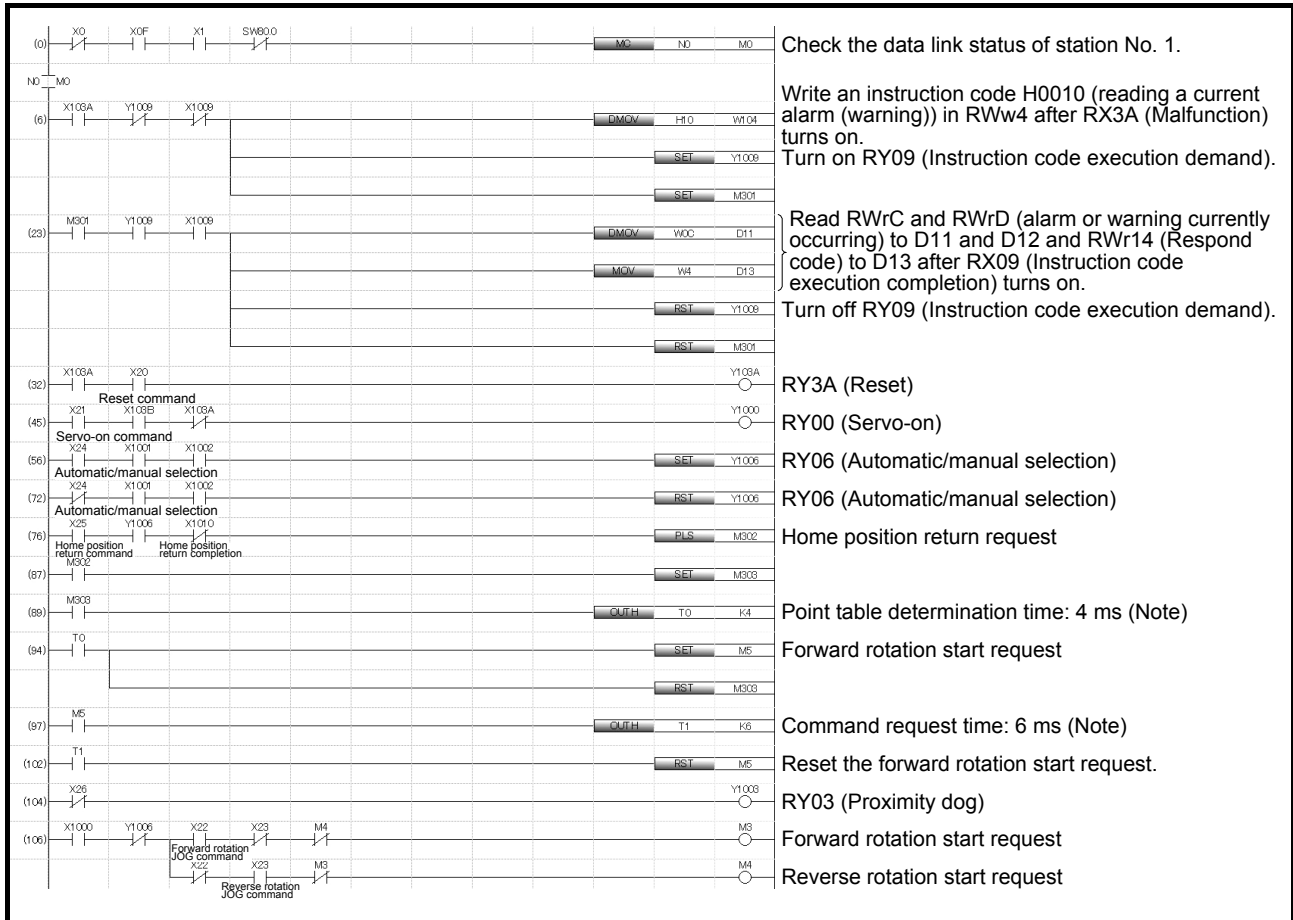

2. POINT TABLE OPERATION

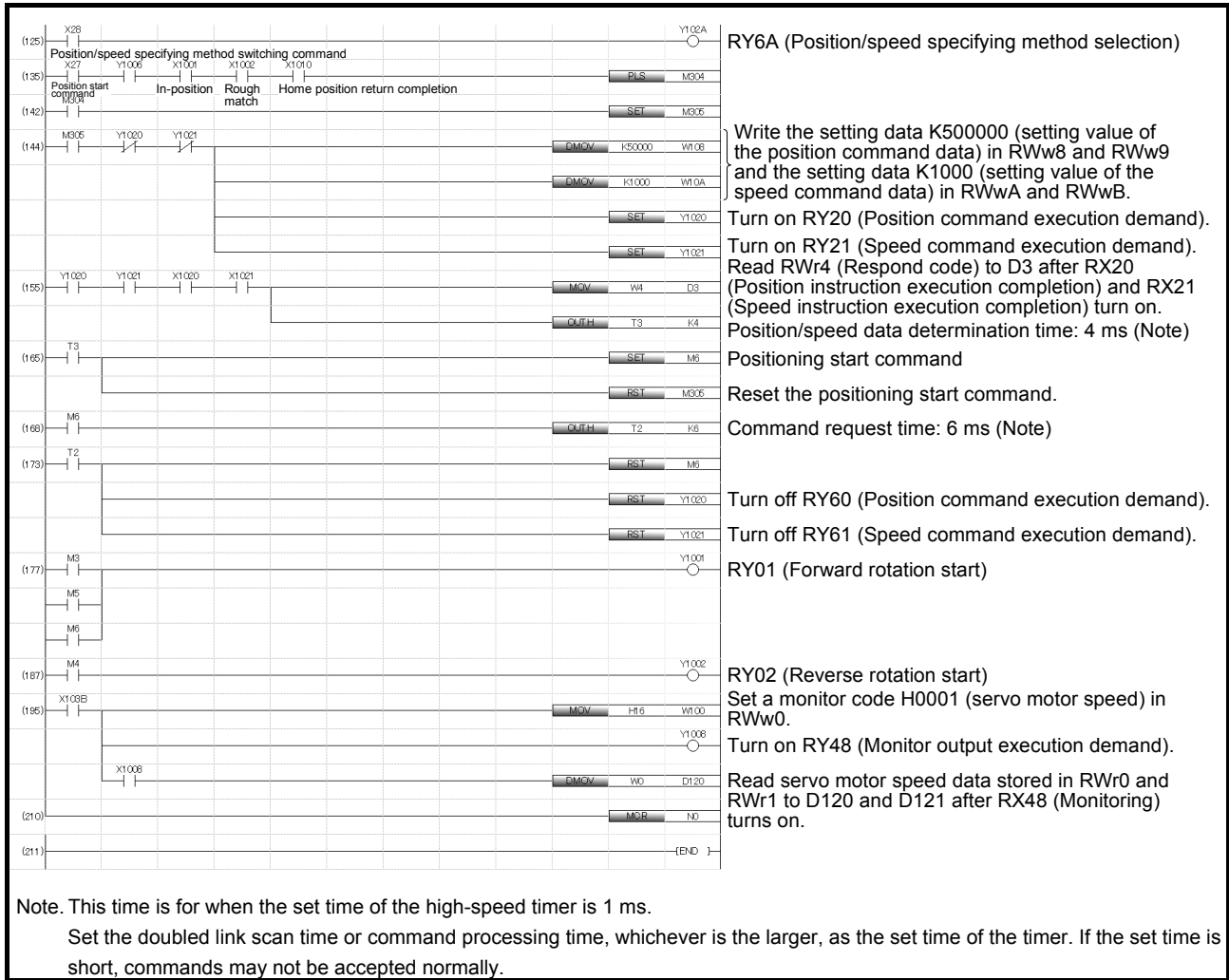

3. PARAMETERS

3. PARAMETERS

CAUTION

- Never make a drastic adjustment or change to the parameter values as doing so will make the operation unstable.
- If fixed values are written in the digits of a parameter, do not change these values.
- Do not change parameters for manufacturer setting.
- Do not set any values other than the described setting values to each parameter.

3.1 Parameter list

POINT

- The parameter whose symbol is preceded by * is enabled with the following conditions:
 - *: After setting the parameter, cycle the power or reset the controller.
 - ** : After setting the parameter, cycle the power.
- Abbreviations of operation modes indicate the followings.
 - Standard: Standard (semi closed loop system) use of the rotary servo motor
 - Full.: Fully closed loop system use of the rotary servo motor
 - Lin.: Linear servo motor use
 - DD: Direct drive (DD) motor use

Refer to chapter 5 in "MR-J4-_GF_(-RJ) Servo Amplifier Instruction Manual (Motion Mode)" for the parameters with "Motion mode" in the detailed explanation field.

3. PARAMETERS

3.1.1 Basic setting parameters ([Pr. PA_ _])

No.	Symbol	Name	Initial value	Unit	Operation mode				Detailed explanation
					Standard	Full.	Lin.	DD	
PA01	**STY	Operation mode	1000h		○	○	○	○	Motion mode
PA02	**REG	Regenerative option	0000h		○	○	○	○	
PA03	*ABS	Absolute position detection system	0000h		○	○	○	○	
PA04	*AOP1	Function selection A-1	2000h		○	○	○	○	
PA05		For manufacturer setting	10000		○	○	○	○	
PA06	*CMX	Electronic gear numerator	1		○	○	○	○	Section 3.2.1
PA07	*CDV	Electronic gear denominator	1		○	○	○	○	
PA08	ATU	Auto tuning mode	0001h		○	○	○	○	Motion mode
PA09	RSP	Auto tuning response	16		○	○	○	○	
PA10	INP	In-position range	1600	[μm]/ 10 ⁻⁴ [inch]/ [pulse]	○	○	○	○	Section 3.2.1
PA11	TLP	Forward rotation torque limit/positive direction thrust limit	1000.0	[%]	○	○	○	○	Motion mode
PA12	TLN	Reverse rotation torque limit/negative direction thrust limit	1000.0	[%]	○	○	○	○	
PA13		For manufacturer setting	0000h		○	○	○	○	
PA14	*POL	Rotation direction selection/travel direction selection	0		○	○	○	○	
PA15	*ENR	Encoder output pulses	4000	[pulse/rev]	○	○	○	○	
PA16	*ENR2	Encoder output pulses 2	1		○	○	○	○	
PA17	**MSR	Servo motor series setting	0000h		○	○	○	○	
PA18	**MTY	Servo motor type setting	0000h		○	○	○	○	
PA19	*BLK	Parameter writing inhibit	00ABh		○	○	○	○	
PA20	*TDS	Tough drive setting	0000h		○	○	○	○	
PA21	*AOP3	Function selection A-3	0001h		○	○	○	○	
PA22	**PCS	Position control composition selection	0000h		○	○	○	○	
PA23	DRAT	Drive recorder arbitrary alarm trigger setting	0000h		○	○	○	○	
PA24	AOP4	Function selection A-4	0000h		○	○	○	○	
PA25	OTHOV	One-touch tuning - Overshoot permissible level	0	[%]	○	○	○	○	
PA26	*AOP5	Function selection A-5	0000h		○	○	○	○	
PA27		For manufacturer setting	0000h		○	○	○	○	
PA28			0000h		○	○	○	○	
PA29			0000h		○	○	○	○	
PA30			0000h		○	○	○	○	
PA31			0000h		○	○	○	○	
PA32			0000h		○	○	○	○	

3. PARAMETERS

3.1.2 Gain/filter setting parameters ([Pr. PB_ _])

No.	Symbol	Name	Initial value	Unit	Operation mode				Detailed explanation
					Standard	Full.	Lin.	DD	
PB01	FILT	Adaptive tuning mode (adaptive filter II)	0000h						Motion mode
PB02	VRFT	Vibration suppression control tuning mode (advanced vibration suppression control II)	0000h						
PB03		For manufacturer setting	18000						
PB04	FFC	Feed forward gain	0	[%]					
PB05		For manufacturer setting	500						
PB06	GD2	Load to motor inertia ratio/load to motor mass ratio	7.00	[Multiplier]					
PB07	PG1	Model loop gain	15.0	[rad/s]					
PB08	PG2	Position loop gain	37.0	[rad/s]					
PB09	VG2	Speed loop gain	823	[rad/s]					
PB10	VIC	Speed integral compensation	33.7	[ms]					
PB11	VDC	Speed differential compensation	980						
PB12	OVA	Overshoot amount compensation	0	[%]					
PB13	NH1	Machine resonance suppression filter 1	4500	[Hz]					
PB14	NHQ1	Notch shape selection 1	0000h						
PB15	NH2	Machine resonance suppression filter 2	4500	[Hz]					
PB16	NHQ2	Notch shape selection 2	0000h						
PB17	NHF	Shaft resonance suppression filter	0000h						
PB18	LPF	Low-pass filter setting	3141	[rad/s]					
PB19	VRF11	Vibration suppression control 1 - Vibration frequency	100.0	[Hz]					
PB20	VRF12	Vibration suppression control 1 - Resonance frequency	100.0	[Hz]					
PB21	VRF13	Vibration suppression control 1 - Vibration frequency damping	0.00						
PB22	VRF14	Vibration suppression control 1 - Resonance frequency damping	0.00						
PB23	VFBF	Low-pass filter selection	0000h						
PB24	*MVS	Slight vibration suppression control	0000h						
PB25	*BOP1	Function selection B-1	0000h						
PB26	*CDP	Gain switching function	0000h						
PB27	CDL	Gain switching condition	10	[kpulse/s]/ [pulse]/ [r/min]					
PB28	CDT	Gain switching time constant	1	[ms]					
PB29	GD2B	Load to motor inertia ratio/load to motor mass ratio after gain switching	7.00	[Multiplier]					
PB30	PG2B	Position loop gain after gain switching	0.0	[rad/s]					
PB31	VG2B	Speed loop gain after gain switching	0	[rad/s]					
PB32	VICB	Speed integral compensation after gain switching	0.0	[ms]					
PB33	VRF11B	Vibration suppression control 1 - Vibration frequency after gain switching	0.0	[Hz]					
PB34	VRF12B	Vibration suppression control 1 - Resonance frequency after gain switching	0.0	[Hz]					
PB35	VRF13B	Vibration suppression control 1 - Vibration frequency damping after gain switching	0.00						
PB36	VRF14B	Vibration suppression control 1 - Resonance frequency damping after gain switching	0.00						
PB37		For manufacturer setting	1600						
PB38			0.00						
PB39			0.00						
PB40			0.00						
PB41			0000h						
PB42			0000h						
PB43			0000h						
PB44			0.00						
PB45	CNHF	Command notch filter	0000h						

3. PARAMETERS

No.	Symbol	Name	Initial value	Unit	Operation mode				Detailed explanation
					Standard	Full.	Lin.	DD	
PB46	NH3	Machine resonance suppression filter 3	4500	[Hz]	○	○	○	○	Motion mode
PB47	NHQ3	Notch shape selection 3	0000h		○	○	○	○	
PB48	NH4	Machine resonance suppression filter 4	4500	[Hz]	○	○	○	○	
PB49	NHQ4	Notch shape selection 4	0000h		○	○	○	○	
PB50	NH5	Machine resonance suppression filter 5	4500	[Hz]	○	○	○	○	
PB51	NHQ5	Notch shape selection 5	0000h		○	○	○	○	
PB52	VRF21	Vibration suppression control 2 - Vibration frequency	100.0	[Hz]	○	○	○	○	
PB53	VRF22	Vibration suppression control 2 - Resonance frequency	100.0	[Hz]	○	○	○	○	
PB54	VRF23	Vibration suppression control 2 - Vibration frequency damping	0.00		○	○	○	○	
PB55	VRF24	Vibration suppression control 2 - Resonance frequency damping	0.00		○	○	○	○	
PB56	VRF21B	Vibration suppression control 2 - Vibration frequency after gain switching	0.0	[Hz]	○	○	○	○	
PB57	VRF22B	Vibration suppression control 2 - Resonance frequency after gain switching	0.0	[Hz]	○	○	○	○	
PB58	VRF23B	Vibration suppression control 2 - Vibration frequency damping after gain switching	0.00		○	○	○	○	
PB59	VRF24B	Vibration suppression control 2 - Resonance frequency damping after gain switching	0.00		○	○	○	○	
PB60	PG1B	Model loop gain after gain switching	0.0	[rad/s]	○	○	○	○	
PB61		For manufacturer setting	0.0						
PB62			0000h						
PB63			0000h						
PB64			0000h						

3.1.3 Extension setting parameters ([Pr. PC_ _])

No.	Symbol	Name	Initial value	Unit	Operation mode				Detailed explanation
					Standard	Full.	Lin.	DD	
PC01	ERZ	Error excessive alarm level	0	[rev]/ [mm]	○	○	○	○	Motion mode
PC02	MBR	Electromagnetic brake sequence output	0	[ms]	○	○	○	○	
PC03	*ENRS	Encoder output pulse selection	0000h		○	○	○	○	
PC04	**COP1	Function selection C-1	0000h		○	○	○	○	
PC05	**COP2	Function selection C-2	0000h		○	○	○	○	
PC06	*COP3	Function selection C-3	0000h		○	○	○	○	
PC07	ZSP	Zero speed	50	[r/min]/ [mm/s]	○	○	○	○	
PC08	OSL	Overspeed alarm detection level	0	[r/min]/ [mm/s]	○	○	○	○	
PC09	MOD1	Analog monitor 1 output	0000h		○	○	○	○	
PC10	MOD2	Analog monitor 2 output	0001h		○	○	○	○	
PC11	MO1	Analog monitor 1 offset	0	[mV]	○	○	○	○	
PC12	MO2	Analog monitor 2 offset	0	[mV]	○	○	○	○	
PC13		For manufacturer setting	0						
PC14			0						
PC15			0						
PC16			0000h						
PC17	**COP4	Function selection C-4	0000h		○	○	○	○	
PC18	*COP5	Function selection C-5	0010h		○	○	○	○	
PC19	*COP6	Function selection C-6	0000h		○	○	○	○	
PC20	*COP7	Function selection C-7	0000h		○	○	○	○	

3. PARAMETERS

No.	Symbol	Name	Initial value	Unit	Operation mode				Detailed explanation
					Standard	Full.	Lin.	DD	
PC21	*BPS	Alarm history clear	0000h						Motion mode
PC22		For manufacturer setting	0						
PC23			0000h						
PC24	RSBR	Forced stop deceleration time constant	100	[ms]					
PC25		For manufacturer setting	0						
PC26	**COP8	Function selection C-8	0000h		(Note)				
PC27	**COP9	Function selection C-9	0000h		(Note)				
PC28		For manufacturer setting	0000h						
PC29	*COPB	Function selection C-B	1000h						
PC30		For manufacturer setting	0						
PC31	RSUP1	Vertical axis freefall prevention compensation amount	0	[0.0001rev]/ [0.01mm]					
PC32		For manufacturer setting	0000h						
PC33			0						
PC34			100						
PC35			0000h						
PC36			0000h						
PC37			0000h						
PC38	ERW	Error excessive warning level	0	[rev]/[mm]					
PC39		For manufacturer setting	0000h						
PC40			0000h						
PC41			0000h						
PC42			0000h						
PC43			0000h						
PC44			0000h						
PC45			0000h						
PC46			0000h						
PC47			0000h						
PC48			0000h						
PC49			0000h						
PC50			0000h						
PC51			0000h						
PC52			0000h						
PC53			0000h						
PC54			0000h						
PC55			0000h						
PC56			0000h						
PC57			0000h						
PC58			0000h						
PC59			0000h						
PC60			0000h						
PC61			0000h						
PC62			0000h						
PC63			0000h						
PC64			0000h						
PC65			50.00						
PC66			10						
PC67	FEWL	Following error output level	0000h	[pulse]					
PC68	FEWH		00C0h						
PC69	FEWF	Following error output filtering time	10	[ms]					

3. PARAMETERS

No.	Symbol	Name	Initial value	Unit	Operation mode				Detailed explanation
					Standard	Full.	Lin.	DD	
PC70		For manufacturer setting	100						Motion mode
PC71			10						
PC72			20.00						
PC73			10						
PC74			10.0						
PC75			10						
PC76	*COPE	Function selection C-E	0001h		<input type="radio"/>	<input type="radio"/>	<input type="radio"/>	<input type="radio"/>	
PC77		For manufacturer setting	0.0						
PC78			0000h						
PC79			0000h						
PC80			0000h						

Note. It is available when the scale measurement function is enabled ([Pr. PA22] is "1 ___" or "2 ___").

3. PARAMETERS

3.1.4 I/O setting parameters ([Pr. PD_ _])

No.	Symbol	Name	Initial value	Unit	Operation mode				Detailed explanation
					Standard	Full.	Lin.	DD	
PD01	*DIA1	Input signal automatic on selection 1	0000h		○	○	○	○	Motion mode
PD02		For manufacturer setting	0000h		○	○	○	○	
PD03	*DI1	Input device selection 1	000Ah		○	○	○	○	
PD04	*DI2	Input device selection 2	000Bh		○	○	○	○	
PD05	*DI3	Input device selection 3	0022h		○	○	○	○	
PD06		For manufacturer setting	0000h		○	○	○	○	
PD07	*DO1	Output device selection 1	0005h		○	○	○	○	
PD08	*DO2	Output device selection 2	0004h		○	○	○	○	
PD09	*DO3	Output device selection 3	0003h		○	○	○	○	
PD10		For manufacturer setting	0000h		○	○	○	○	
PD11	*DIF	Input filter setting	0004h		○	○	○	○	
PD12	*DOP1	Function selection D-1	0101h		○	○	○	○	
PD13	*DOP2	Function selection D-2	0000h		○	○	○	○	Motion mode
PD14	*DOP3	Function selection D-3	0000h		○	○	○	○	
PD15		For manufacturer setting	0000h						
PD16			0000h						
PD17			0000h						
PD18			0000h						
PD19			0000h						
PD20			0						
PD21			0						
PD22			0						
PD23			0						
PD24			0000h						
PD25			0000h						
PD26			0000h						
PD27			0000h						
PD28			0000h						
PD29			0000h						
PD30			0						
PD31			0						
PD32			0						
PD33			0000h						
PD34			0000h						
PD35		0000h							
PD36		0000h							
PD37	*TPOP	Touch probe function selection	0000h		○	○	○	○	
PD38		For manufacturer setting	002Ch						
PD39			002Dh						
PD40			0						
PD41	*DOP4	Function selection D-4	0000h		○	○	○	○	
PD42		For manufacturer setting	0000h						
PD43			0000h						
PD44			0000h						
PD45			0000h						
PD46			0000h						
PD47			0000h						
PD48			0000h						

3. PARAMETERS

3.1.5 Extension setting 2 parameters ([Pr. PE_ _])

No.	Symbol	Name	Initial value	Unit	Operation mode				Detailed explanation
					Standard	Full.	Lin.	DD	
PE01	**FCT1	Fully closed loop function selection 1	0000h			<input type="radio"/>			Motion mode
PE02		For manufacturer setting	0000h						
PE03	*FCT2	Fully closed loop function selection 2	0003h			<input type="radio"/>			
PE04	**FBN	Fully closed loop control - Feedback pulse electronic gear 1 - Numerator	1			<input type="radio"/>			
PE05	**FBD	Fully closed loop control - Feedback pulse electronic gear 1 - Denominator	1			<input type="radio"/>			
PE06	BC1	Fully closed loop control - Speed deviation error detection level	400	[r/min]		<input type="radio"/>			
PE07	BC2	Fully closed loop control - Position deviation error detection level	100	[kpulse]		<input type="radio"/>			
PE08	DUF	Fully closed loop dual feedback filter	10	[rad/s]		<input type="radio"/>			
PE09		For manufacturer setting	0000h						
PE10	FCT3	Fully closed loop function selection 3	0000h			<input type="radio"/>			
PE11		For manufacturer setting	0000h						
PE12			0000h						
PE13			0000h						
PE14			0111h						
PE15			20						
PE16			0000h						
PE17			0000h						
PE18			0000h						
PE19			0000h						
PE20			0000h						
PE21			0000h						
PE22			0000h						
PE23			0000h						
PE24			0000h						
PE25		0000h							
PE26		0000h							
PE27		0000h							
PE28		0000h							
PE29		0000h							
PE30		0000h							
PE31		0000h							
PE32		0000h							
PE33		0000h							
PE34	**FBN2	Fully closed loop control - Feedback pulse electronic gear 2 - Numerator	1			<input type="radio"/>			
PE35	**FBD2	Fully closed loop control - Feedback pulse electronic gear 2 - Denominator	1			<input type="radio"/>			
PE36		For manufacturer setting	0.0						
PE37			0.00						
PE38			0.00						
PE39			20						
PE40			0000h						
PE41	EOP3	Function selection E-3	0000h			<input type="radio"/>	<input type="radio"/>	<input type="radio"/>	<input type="radio"/>

3. PARAMETERS

No.	Symbol	Name	Initial value	Unit	Operation mode				Detailed explanation
					Standard	Full.	Lin.	DD	
PE42		For manufacturer setting	0						Motion mode
PE43			0.0						
PE44	LMCP	Lost motion compensation positive-side compensation value selection	0	[0.01%]	<input type="radio"/>	<input type="radio"/>	<input type="radio"/>	<input type="radio"/>	
PE45	LMCN	Lost motion compensation negative-side compensation value selection	0	[0.01%]	<input type="radio"/>	<input type="radio"/>	<input type="radio"/>	<input type="radio"/>	
PE46	LMFLT	Lost motion filter setting	0	[0.1 ms]	<input type="radio"/>	<input type="radio"/>	<input type="radio"/>	<input type="radio"/>	
PE47	TOF	Torque offset	0	[0.01%]	<input type="radio"/>	<input type="radio"/>	<input type="radio"/>	<input type="radio"/>	
PE48	*LMOP	Lost motion compensation function selection	0000h		<input type="radio"/>	<input type="radio"/>	<input type="radio"/>	<input type="radio"/>	
PE49	LMCD	Lost motion compensation timing	0	[0.1 ms]	<input type="radio"/>	<input type="radio"/>	<input type="radio"/>	<input type="radio"/>	
PE50	LMCT	Lost motion compensation non-sensitive band	0	[pulse]/ [kpulse]	<input type="radio"/>	<input type="radio"/>	<input type="radio"/>	<input type="radio"/>	
PE51		For manufacturer setting	0000h						
PE52			0000h						
PE53			0000h						
PE54			0000h						
PE55			0000h						
PE56			0000h						
PE57			0000h						
PE58			0000h						
PE59			0000h						
PE60			0000h						
PE61			0.00						
PE62			0.00						
PE63			0.00						
PE64			0.00						

3.1.6 Extension setting 3 parameters ([Pr. PF_ _])

No.	Symbol	Name	Initial value	Unit	Operation mode				Detailed explanation
					Standard	Full.	Lin.	DD	
PF01		For manufacturer setting	0000h						Motion mode
PF02			0000h						
PF03			0000h						
PF04			0						
PF05			0000h						
PF06	*FOP5	Function selection F-5	0000h		<input type="radio"/>	<input type="radio"/>	<input type="radio"/>	<input type="radio"/>	
PF07		For manufacturer setting	0000h						
PF08			0000h						
PF09			0						
PF10			0						
PF11			0						
PF12	DBT	Electronic dynamic brake operating time	2000	[ms]	<input type="radio"/>	<input type="radio"/>	<input type="radio"/>	<input type="radio"/>	
PF13		For manufacturer setting	0000h						
PF14			10						
PF15			0000h						
PF16			0000h						
PF17			0000h						

3. PARAMETERS

No.	Symbol	Name	Initial value	Unit	Operation mode				Detailed explanation
					Standard	Full.	Lin.	DD	
PF18	**STOD	STO diagnosis error detection time	10	[s]	<input type="radio"/>	<input type="radio"/>	<input type="radio"/>	<input type="radio"/>	Motion mode
PF19		For manufacturer setting	0000h						
PF20			0000h						
PF21	DRT	Drive recorder switching time setting	0	[s]	<input type="radio"/>	<input type="radio"/>	<input type="radio"/>	<input type="radio"/>	
PF22		For manufacturer setting	200						
PF23		OSCL1	Vibration tough drive - Oscillation detection level						
PF24	*OSCL2	Vibration tough drive function selection	0000h		<input type="radio"/>	<input type="radio"/>	<input type="radio"/>	<input type="radio"/>	
PF25	CVAT	SEMI-F47 function - Instantaneous power failure detection time	200	[ms]	<input type="radio"/>	<input type="radio"/>	<input type="radio"/>	<input type="radio"/>	
PF26		For manufacturer setting	0						
PF27			0						
PF28			0						
PF29		For manufacturer setting	0000h						
PF30			0						
PF31	FRIC	Machine diagnosis function - Friction judgement speed	0	[r/min]/ [mm/s]	<input type="radio"/>	<input type="radio"/>	<input type="radio"/>	<input type="radio"/>	
PF32		For manufacturer setting	50						
PF33			0000h						
PF34			0000h						
PF35			0000h						
PF36			0000h						
PF37			0000h						
PF38			0000h						
PF39			0000h						
PF40			0000h						
PF41			0000h						
PF42			0000h						
PF43			0000h						
PF44			0						
PF45			0000h						
PF46			0000h						
PF47			0000h						
PF48			0000h						
PF49			100						
PF50			100						
PF51			0000h						
PF52			0000h						
PF53			0						
PF54			0						
PF55			0						
PF56			0						
PF57			0000h						
PF58			0000h						
PF59			0000h						
PF60			0000h						
PF61			0000h						
PF62			0000h						
PF63			0000h						
PF64			0000h						

3. PARAMETERS

3.1.7 Linear servo motor/DD motor setting parameters ([Pr. PL_ _])

No.	Symbol	Name	Initial value	Unit	Operation mode				Detailed explanation
					Standard	Full.	Lin.	DD	
PL01	**LIT1	Linear servo motor/DD motor function selection 1	0301h				<input type="radio"/>	<input type="radio"/>	Motion mode
PL02	**LIM	Linear encoder resolution - Numerator	1000	[μ m]			<input type="radio"/>	<input type="radio"/>	
PL03	**LID	Linear encoder resolution - Denominator	1000	[μ m]			<input type="radio"/>	<input type="radio"/>	
PL04	*LIT2	Linear servo motor/DD motor function selection 2	0003h				<input type="radio"/>	<input type="radio"/>	
PL05	LB1	Position deviation error detection level	0	[mm]/ [0.01rev]			<input type="radio"/>	<input type="radio"/>	
PL06	LB2	Speed deviation error detection level	0	[mm/s]/ [r/min]			<input type="radio"/>	<input type="radio"/>	
PL07	LB3	Torque/thrust deviation error detection level	100	[%]			<input type="radio"/>	<input type="radio"/>	
PL08	*LIT3	Linear servo motor/DD motor function selection 3	0010h				<input type="radio"/>	<input type="radio"/>	
PL09	LPWM	Magnetic pole detection voltage level	30	[%]			<input type="radio"/>	<input type="radio"/>	
PL10		For manufacturer setting	5						
PL11			100						
PL12			500						
PL13			0000h						
PL14			0000h						
PL15			20						
PL16			0						
PL17	LTSTS	Magnetic pole detection - Minute position detection method - Function selection	0000h				<input type="radio"/>	<input type="radio"/>	
PL18	IDLV	Magnetic pole detection - Minute position detection method - Identification signal amplitude	0	[%]			<input type="radio"/>	<input type="radio"/>	
PL19		For manufacturer setting	0						
PL20			0						
PL21			0						
PL22			0						
PL23			0000h						
PL24			0						
PL25			0000h						
PL26			0000h						
PL27			0000h						
PL28			0000h						
PL29			0000h						
PL30			0000h						
PL31			0000h						
PL32			0000h						
PL33			0000h						
PL34			0000h						
PL35			0000h						
PL36			0000h						
PL37			0000h						
PL38			0000h						
PL39			0000h						
PL40			0000h						
PL41			0000h						
PL42			0000h						
PL43			0000h						
PL44			0000h						
PL45			0000h						

3. PARAMETERS

No.	Symbol	Name	Initial value	Unit	Operation mode				Detailed explanation
					Standard	Full.	Lin.	DD	
PL46		For manufacturer setting	0000h						Motion mode
PL47			0000h						
PL48			0000h						

3.1.8 Positioning control parameters ([Pr. PT__])

No.	Symbol	Name	Initial value	Unit	Operation mode				Detailed explanation
					Standard	Full.	Lin.	DD	
PT01	**CTY	Command mode selection	0300h						Section 3.2.3
PT02		For manufacturer setting	0001h						
PT03	*FTY	Feeding function selection	0000h						
PT04		For manufacturer setting	0000h						Motion mode
PT05	ZRF	Home position return speed	100.00	[r/min]/ [mm/s]					
PT06	CRF	Creep speed	10.00	[r/min]/ [mm/s]					
PT07	ZST	Home position shift distance	0	[μm]/ 10 ⁻⁴ [inch]/ [pulse]					Section 3.2.3
PT08		For manufacturer setting	0						
PT09	DCT	Travel distance after proximity dog	0	10 ^{STM} [μm]/ 10 ^(STM-4) [inch]/ [pulse]					
PT10	ZTM	Stopper type home position return stopper time	100	[ms]					Motion mode
PT11	ZTT	Stopper type home position return torque limit value	15.0	[%]					
PT12	CRP	Rough match output range	0	10 ^{STM} [μm]/ 10 ^(STM-4) [inch]/ [pulse]					Section 3.2.3
PT13		For manufacturer setting	100						
PT14			0						
PT15	LMPL	Software limit +	0000h	10 ^{STM} [μm]/ 10 ^(STM-4) [inch]/ [pulse]					
PT16	LMPH		0000h						
PT17	LMNL	Software limit -	0000h	10 ^{STM} [μm]/ 10 ^(STM-4) [inch]/ [pulse]					
PT18	LMNH		0000h						
PT19	*LPPL	Position range output address +	0000h	10 ^{STM} [μm]/ 10 ^(STM-4) [inch]/ [pulse]					
PT20	*LPPH		0000h						
PT21	*LNPL	Position range output address -	0000h	10 ^{STM} [μm]/ 10 ^(STM-4) [inch]/ [pulse]					
PT22	*LNPH		0000h						
PT23		For manufacturer setting	0						
PT24			0						
PT25			0						
PT26			0000h						
PT27			0000h						
PT28			8						
PT29	*TOP3	Function selection T-3	0000h						
PT30		For manufacturer setting	0000h						
PT31			0000h						

3. PARAMETERS

No.	Symbol	Name	Initial value	Unit	Operation mode				Detailed explanation
					Standard	Full.	Lin.	DD	
PT32		For manufacturer setting	0000h						Section 3.2.3
PT33			0000h						
PT34	*PDEF	Point table default	0000h		○	○	○	○	
PT35		For manufacturer setting	0000h						Section 3.2.3
PT36			0000h						
PT37			10						
PT38			0000h						
PT39			100						
PT40			0						
PT41	ORP	Home position return inhibit function selection	0000h		○	○	○	○	Motion mode
PT42		For manufacturer setting	0						
PT43			0						
PT44			0000h						
PT45	HMM	Home position return type	37		○	○	○	○	
PT46		For manufacturer setting	0000h						Section 3.2.3
PT47			0000h						
PT48			0000h						
PT49	STA	Acceleration time constant	0	[ms]	○	○	○	○	Section 3.2.3
PT50	STB	Deceleration time constant	0	[ms]	○	○	○	○	
PT51	STC	S-pattern acceleration/deceleration time constant	0	[ms]	○	○	○	○	
PT52		For manufacturer setting	0						Motion mode
PT53			0.0						
PT54			0						
PT55	*TOP8	Function selection T-8	0000h		○	○	○	○	
PT56	HMA	Home position return acceleration time constant	0	[ms]	○	○	○	○	
PT57	HMB	Home position return deceleration time constant	0	[ms]	○	○	○	○	
PT58		For manufacturer setting	100.00						Section 3.2.3
PT59			500.00						
PT60			1000.00						
PT61			200.00						
PT62	*DSS	Remote register-based position/speed specifying method selection	0000h		○	○	○	○	
PT63		For manufacturer setting	0000h						Motion mode
PT64			0000h						
PT65	PVC	Jog speed command	100.00	[r/min]/ [mm/s]	○	○	○	○	Section 3.2.3
PT66		For manufacturer setting	20000.00						Motion mode
PT67	VLMT	Speed limit	500.00	[r/min]/ [mm/s]	○	○	○	○	
PT68		For manufacturer setting	0102h						
PT69	ZSTH	Home position shift distance (extension parameter)	0	[μm]/ 10 ⁻⁴ [inch]/ [pulse]	○	○	○	○	Section 3.2.3
PT70		For manufacturer setting	0000h						Motion mode
PT71	DCTH	Travel distance after proximity dog (extension parameter)	0	10 ^{STM} [μm]/ 10 ^(STM-4) [inch]/ [pulse]	○	○	○	○	Section 3.2.3

3. PARAMETERS

No.	Symbol	Name	Initial value	Unit	Operation mode				Detailed explanation
					Standard	Full.	Lin.	DD	
PT72		For manufacturer setting	0000h						Motion mode
PT73			0000h						
PT74			0000h						
PT75			0000h						
PT76			0000h						
PT77			0000h						
PT78			0000h						
PT79			0000h						
PT80			0000h						

3.1.9 Network setting parameters ([Pr. PN_ _])

No.	Symbol	Name	Initial value	Unit	Operation mode				Detailed explanation
					Standard	Full.	Lin.	DD	
PN01		For manufacturer setting	0						Motion mode
PN02	CERT	Communication error detection time	0	[ms]	<input type="radio"/>	<input type="radio"/>	<input type="radio"/>	<input type="radio"/>	
PN03	**NWMD	Communication mode setting for CC-Link IE communication	0000h		<input type="radio"/>	<input type="radio"/>	<input type="radio"/>	<input type="radio"/>	Section 3.2.4
PN04	**NWNO	CC-Link IE communication network number	0		<input type="radio"/>	<input type="radio"/>	<input type="radio"/>	<input type="radio"/>	Motion mode
PN05	CERI	Communication error detection frequency setting	0	[%]	<input type="radio"/>	<input type="radio"/>	<input type="radio"/>	<input type="radio"/>	
PN06	NOP1	Function selection N-1	0000h		<input type="radio"/>	<input type="radio"/>	<input type="radio"/>	<input type="radio"/>	Section 3.2.4
PN07		For manufacturer setting	0000h						Motion mode
PN08			0000h						
PN09			0000h						
PN10			0000h						
PN11			0000h						
PN12			0000h						
PN13			0000h						
PN14			0000h						
PN15			0000h						
PN16			0000h						
PN17			0000h						
PN18			0000h						
PN19			0000h						
PN20			0000h						
PN21			0000h						
PN22			0000h						
PN23			0000h						
PN24			0000h						
PN25			0000h						
PN26			0000h						
PN27			0000h						
PN28			0000h						
PN29			0000h						
PN30			0000h						
PN31			0000h						
PN32			0000h						

3. PARAMETERS

3.2 Detailed list of parameters

POINT
<ul style="list-style-type: none"> ● For parameters which are not described in this section, refer to chapter 5 of "MR-J4-<u> </u>GF_<u> </u>(-RJ) Servo Amplifier Instruction Manual (Motion Mode)". ● Set a value to each "x" in the "Setting digit" columns.

3.2.1 Basic setting parameters ([Pr. PA])

No./symbol/ name	Setting digit	Function	Initial value [unit]
PA06 *CMX Electronic gear numerator		Set an electronic gear numerator. (Refer to section 3.3.1.) Set the electronic gear within the following range. Setting out of the range will trigger [AL. 37 Parameter error]. 1/865 < CMX/CDV < 2717471 Setting range: 1 to 16777215	1
PA07 *CDV Electronic gear numerator		Set an electronic gear denominator. (Refer to section 3.3.1.) Set the electronic gear within the range of [Pr. PA06]. Setting out of the range will trigger [AL. 37 Parameter error]. Setting range: 1 to 16777215	1
PA10 INP In-position range		Set an in-position range per command pulse. To change it to the servo motor encoder pulse unit, set [Pr. PC06]. In the I/O mode, the in-position range is the range where RXnC (Travel completion) and RXn1 (In-position) are outputted. When [Pr. PC06] is set to "___ 0", the unit can be changed to [μm], 10 ⁻⁴ [inch], or [pulse] with the setting of [Pr. PT01]. When [Pr. PC06] is set to "___ 1", the unit is fixed to [pulse]. Setting range: 0 to 65535	1600 Refer to Function column for unit.

3.2.2 I/O setting parameters ([Pr. PD])

No./symbol/ name	Setting digit	Function	Initial value [unit]
PD12 *DOP1 Function selection D-1	___ x	Stop method selection for RY (n + 1) 0 (Upper stroke limit) off or RY (n + 1) 1 (Lower stroke limit) off Select a stop method for RY (n + 1) 0 (Upper stroke limit) off or RY (n + 1) 1 (Lower stroke limit) off. (Refer to section 3.4.) 1: Slow stop 2: Slow stop (deceleration to a stop by deceleration time constant) 3: Quick stop (stop by clearing remaining distance) Setting "0" will trigger [AL. 37].	1h
	__ x _	For manufacturer setting	0h
	_ x _ _	Stop method selection at software limit detection Select a stop method selection at software limit detection. (Refer to section 3.5.) 1: Slow stop 2: Slow stop (deceleration to a stop by deceleration time constant) 3: Quick stop (stop by clearing remaining distance) Setting "0" will trigger [AL. 37].	1h
	x _ _ _	Servo motor thermistor enabled/disabled selection 0: Enabled 1: Disabled For servo motors without thermistor, the setting will be disabled.	0h

3. PARAMETERS

3.2.3 Positioning control parameters ([Pr. PT_ _])

No./symbol/ name	Setting digit	Function	Initial value [unit]
PT01 **CTY Command mode selection	___x	Positioning command method selection 0: Absolute value command method 1: Incremental value command method	0h
	__x_	For manufacturer setting	0h
	_x__	Position data unit 0: mm 1: inch 3: pulse	3h
	x___	For manufacturer setting	0h
PT03 *FTY Feeding function selection	___x	Feed length multiplication (STM) 0: × 1 1: × 10 2: × 100 3: × 1000 This digit will be disabled when [pulse] of "Position data unit" is set in [Pr. PT01].	0h
	__x_	For manufacturer setting	0h
	_x__		0h
	x___		0h
PT07 ZST Home position shift distance		Set a shift distance from the Z-phase pulse detection position in the encoder. Up to 2^{31} can be set with [Pr. PT69]. The unit can be changed to [μm], 10^{-4} [inch], or [pulse] with the setting of [Pr. PT01]. Setting range: 0 to 65535	0 Refer to Function column for unit.
PT09 DCT Travel distance after proximity dog		Set a travel distance after proximity dog for the count type home position return (front end detection, Z-phase reference) (Homing method -2, -34) and the following dog reference home position returns. The following shows the home position return of the dog reference. • Dog type rear end reference home position return (Homing method -6, -38) • Count type home position return (Front end reference) (Homing method -7, -39) • Dog type front end reference home position return (Homing method -10, -42) • Homing without index pulse (Homing method 19, 20, 21, 22, 23, 24, 27, 28) Up to 2^{31} can be set with [Pr. PT71]. The unit can be changed to 10^{STM} [μm], $10^{(\text{STM}-4)}$ [inch], or [pulse] with the setting of [Pr. PT01]. Setting range: 0 to 65535	0 Refer to Function column for unit.
PT12 CRP Rough match output range		Set a range of the command remaining distance which outputs rough match. The unit can be changed to 10^{STM} [μm], $10^{(\text{STM}-4)}$ [inch], or [pulse] with the setting of [Pr. PT01]. Setting range: 0 to 65535	0 Refer to Function column for unit.

3. PARAMETERS

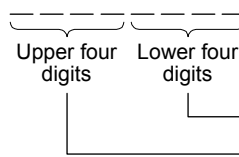
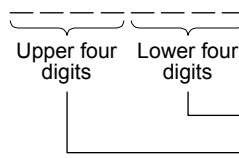
No./symbol/ name	Setting digit	Function	Initial value [unit]
PT15 LMPL Software limit + (lower four digits)		Set an address increasing side of the software stroke limit. Upper and lower are a set. Set the setting address in hexadecimal. Setting address: 	0000h Refer to Function column for unit.
PT16 LMPH Software limit + (upper four digits)			0000h Refer to Function column for unit.
Setting a same value with "Software limit -" will disable the software limit. (Refer to section 5.3 of "MR-J4-_GF_(-RJ) Servo Amplifier Instruction Manual (Motion Mode)".) When changing the parameter setting with MR Configurator2, change it during servo-off or in the home position return mode. The unit can be changed to 10 ^{STM} [μm], 10 ^(STM-4) [inch], or [pulse] with the setting of [Pr. PT01]. Setting range: 0000h 0000h to FFFFh FFFFh			
PT17 LMNL Software limit - (lower four digits)		Set an address decreasing side of the software stroke limit. Upper and lower are a set. Set the setting address in hexadecimal. Setting address: 	0000h Refer to Function column for unit.
PT18 LMNH Software limit - (upper four digits)			0000h Refer to Function column for unit.
Setting a same value with "Software limit +" will disable the software limit. (Refer to section 5.3 of "MR-J4-_GF_(-RJ) Servo Amplifier Instruction Manual (Motion Mode)".) When changing the parameter setting with MR Configurator2, change it during servo-off or in the home position return mode. The unit can be changed to 10 ^{STM} [μm], 10 ^(STM-4) [inch], or [pulse] with the setting of [Pr. PT01]. Setting range: 0000h 0000h to FFFFh FFFFh			

3. PARAMETERS

No./symbol/ name	Setting digit	Function	Initial value [unit]
PT19 *LPPL Position range output address + (lower four digits)		Set an address increasing side of the position range output address. Upper and lower are a set. Set a range which RXnE (Position range) turns on with [Pr. PT19] to [Pr. PT22]. Setting address:	0000h Refer to Function column for unit.
PT20 *LPPH Position range output address + (upper four digits)			0000h Refer to Function column for unit.
PT21 *LNPL Position range output address - (lower four digits)		Set an address decreasing side of the position range output address. Upper and lower are a set. Set a range which RXnE (Position range) turns on with [Pr. PT19] to [Pr. PT22]. Setting address:	0000h Refer to Function column for unit.
PT22 *LNPH Position range output address - (upper four digits)			0000h Refer to Function column for unit.
PT34 **PDEF Point table default		Use this parameter when initializing point tables. The point tables will be all "0" by initializing. Initialize them with the following procedure. 1) Set "5001h" to this parameter. 2) Cycle the power of the servo amplifier. After the servo amplifier power is on, the initialization completes in about 20 s. "dEF" will be displayed on the display (five-digit, seven-segment LED) during the initialization. After the initialization, the setting of this parameter will be "0000h" automatically.	0000h
PT49 STA Acceleration time constant		Set an acceleration time from 0 r/min or 0 mm/s to the rated speed for the command. If the servo motor is started when a value exceeding 20000 ms is set, [AL. F4] will occur, and the servo motor will not operate. For example for the servo motor of 3000 r/min rated speed, set 3000 (3 s) to increase speed from 0 r/min to 1000 r/min in 1 s. Setting range: 0 to 50000	0 [ms]

3. PARAMETERS

No./symbol/ name	Setting digit	Function	Initial value [unit]
PT50 STB Deceleration time constant		Set a deceleration time from the rated speed to 0 r/min or 0 mm/s for the command. If the servo motor is started when a value exceeding 20000 ms is set, [AL. F4] will occur, and the servo motor will not operate. Setting range: 0 to 50000	0 [ms]
PT51 STC S-pattern acceleration/ deceleration time constant		<p>This enables to start/stop the servo motor or linear servo motor smoothly. Set the time of the arc part for S-pattern acceleration/deceleration. Setting "0" will make it linear acceleration/deceleration.</p> <p>Long setting of STA ([Pr. PT49 Acceleration time constant]) or STB ([Pr. PT50 Deceleration time constant]) may produce an error in the time of the arc part for the setting of the S-pattern acceleration/deceleration time constant. The setting will be disabled at home position return. When 1000 ms or more value is set, it will be clamped to 1000 ms.</p> <p>The upper limit value of the actual arc part time is limited by</p> $\frac{2000000}{STA} \text{ for acceleration or by } \frac{2000000}{STB} \text{ for deceleration.}$ <p>(Example) At the setting of STA 20000, STB 5000 and STC 200, the actual arc part times are as follows.</p> <p>During acceleration: 100 ms $\frac{2000000}{20000} = 100 \text{ [ms]} < 200 \text{ [ms]}$ Therefore, it will be limited to 100 [ms].</p> <p>During deceleration: 200 ms $\frac{2000000}{5000} = 400 \text{ [ms]} > 200 \text{ [ms]}$ Therefore, it will be 200 [ms] as you set.</p> <p>Setting range: 0 to 5000</p>	0 [ms]
PT62 *DSS Remote register-based position/ speed specifying method selection	___ x	Point table method position/speed specifying method selection To enable the parameter, turn on link device RY (n + 2) A (position/speed specifying method selection). Select a setting value according to the position command and speed command in the following table.	0h
	___ x		0h
	_ x _		0h
	x _ _		0h

3. PARAMETERS

No./symbol/ name	Setting digit	Function	Initial value [unit]
PT65 PVC Jog speed command		Set a Jog speed command. If a value smaller than "1.00" is set, the servo motor may not rotate. Setting range: 0.00 to permissible instantaneous speed	100.00 [r/min]/ [mm/s]
PT69 ZSTH Home position shift distance (extension parameter)		Set the extension parameter of [Pr. PT07]. When [Pr. PT69] is used, the home position shift distance can be calculated as follows. Home position shift distance = [Pr. PT07] + ([Pr. PT69] × 65536) The unit can be changed to [μm], 10 ⁻⁴ [inch], or [pulse] with the setting of [Pr. PT01]. Setting range: 0 to 32767	0 Refer to Function column for unit.
PT71 DCTH Travel distance after proximity dog (extension parameter)		Set the extension parameter of [Pr. PT09]. When [Pr. PT71] is used, the travel distance after proximity dog can be calculated as follows. Travel distance after proximity dog = [Pr. PT09] + ([Pr. PT71] × 65536) The unit can be changed to 10 ^{STM} [μm], 10 ^(STM-4) [inch], or [pulse] with the setting of [Pr. PT01]. Setting range: 0 to 32767	0 Refer to Function column for unit.

3.2.4 Network setting parameters ([Pr. PN_ _])

No./symbol/ name	Setting digit	Function	Initial value [unit]
PN03 **NWMD Communi- cation mode setting for CC-Link IE communi- cation	___x	Station-specific mode setting Select the motion mode for connection with a simple motion module or the I/O mode for connection with a master/local module. 0: Motion mode 1: I/O mode	0h
	__x_	For manufacturer setting	0h
	_x__		0h
	x___		0h
PN06 NOP1 Function selection N-1	___x	Communication error alarm history writing selection Select whether [AL. 8D.1 CC-Link IE communication error 1] and [AL. 8D.2 CC-Link IE communication error 2] are recorded in the alarm history at their occurrence. 0: Disabled 1: Enabled When the parameter is set to "1", follow the correct procedure for turning off the power to prevent the occurrence of [AL. 8D.1] or [AL. 8D.2] at power supply shut-off (network disconnection). For details, refer to [Pr. PN06 Communication error detection method selection].	0h
	__x_	Communication error detection method selection Select the condition for detecting the occurrences of [AL. 8D.1 CC-Link IE communication error 1] and [AL. 8D.2 CC-Link IE communication error 2]. 0: Detected only at servo-on. 1: Continuously detected. When the parameter is set to "0", if link device RYn0 (servo-on) is set to "1" in the I/O mode, [AL. 8D.1] and [AL. 8D.2] are detected. When turning off the power in the I/O mode, set link device RYn0 to "0" first. When the parameter is set to "1", [AL. 8D.1] and [AL. 8D.2] are continuously detected while data is being linked. When turning off the power, turn off the servo amplifier first and then the controller.	0h
	_x__	For manufacturer setting	0h
	x___		0h

3. PARAMETERS

3.3 How to set the electronic gear

3.3.1 Electronic gear settings in the point table method and program method

(1) Setting [mm], [inch], or [pulse] with "Position data unit" of [Pr. PT01].

Adjust [Pr. PA06] and [Pr. PA07] so that the servo motor setting matches with the travel distance of the machine.

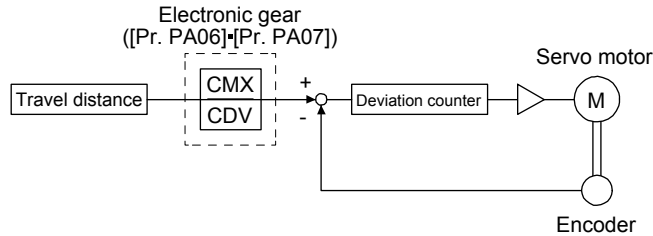

Pt: Servo motor encoder resolution: 4194304 [pulse/rev]
 ΔS : Travel distance per servo motor revolution [mm/rev]/[inch/rev]/[pulse/rev]
 $CMX/CDV = Pt/\Delta S$

The following setting example explains how to calculate the electronic gear.

POINT
<p>● To calculate the electronic gear, the following specification symbols are required.</p> <p>Pb: Ball screw lead [mm]</p> <p>1/n: Reduction ratio</p> <p>Pt: Servo motor encoder resolution [pulse/rev]</p> <p>ΔS: Travel distance per servo motor revolution [mm/rev]</p>

(a) Setting example of a ball screw

Machine specifications

Ball screw lead Pb = 10 [mm]

Reduction ratio: $1/n = Z_1/Z_2 = 1/2$

Z₁: Number of gear teeth on servo motor side

Z₂: Number of gear teeth on load gear

Servo motor encoder resolution Pt = 4194304 [pulse/rev]

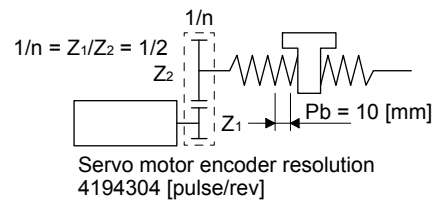

$$\frac{CMX}{CDV} = \frac{Pt}{\Delta S} = \frac{Pt}{n \cdot Pb \cdot \alpha \text{ (Note)}} = \frac{4194304}{1/2 \cdot 10 \cdot 1000} = \frac{4194304}{5000} = \frac{524288}{625}$$

Note. Because the command unit is "mm", $\alpha = 1000$ is set. When the unit is "inch", convert the setting into $\alpha = 10000$. When the unit is "pulse", convert the setting into $\alpha = 1$.

Therefore, set CMX = 524288 and CDV = 625.

3. PARAMETERS

(b) Setting example of a conveyor

Machine specifications

Pulley diameter: $r = 160$ [mm]

Reduction ratio: $1/n = Z_1/Z_2 = 1/3$

Z_1 : Number of gear teeth on servo motor side

Z_2 : Number of gear teeth on load gear

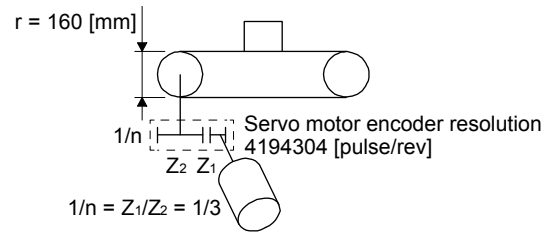

Servo motor encoder resolution $P_t = 4194304$ [pulse/rev]

$$\frac{CMX}{CDV} = \frac{P_t}{\Delta S} = \frac{P_t}{n \cdot r \cdot \pi \cdot \alpha \text{ (Note)}} = \frac{4194304}{1/3 \cdot 160 \cdot \pi \cdot 1000} = \frac{4194304}{167551.61} \approx \frac{524288}{20944}$$

Note. Because the command unit is "mm", $\alpha = 1000$ is set. When the unit is "inch", convert the setting into $\alpha = 10000$. When the unit is "pulse", convert the setting into $\alpha = 1$.

Reduce CMX and CDV to within the setting range or lower and round off each value to the closest whole number.

Therefore, set $CMX = 524288$ and $CDV = 20944$.

3. PARAMETERS

3.4 Stop method for RY (n + 1) 0 (Upper stroke limit) off or RY (n + 1) 1 (Lower stroke limit) off

Select a servo motor stop method for when RY (n + 1) 0 (Upper stroke limit) or RY (n + 1) 1 (Lower stroke limit) is off with the first digit of [Pr. PD12].

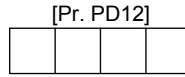

- Stop method selection for RY (n + 1) 0 (Upper stroke limit) off or RY (n + 1) 1 (Lower stroke limit) off
- 1: Slow stop
 - 2: Slow stop (deceleration to a stop by deceleration time constant)
 - 3: Quick stop (stop by clearing remaining distance)

[Pr. PD12] setting	Operation status		Remark
	During rotation at constant speed	During deceleration to a stop	
<p>--- 1 (initial value)</p> <p>— No S-pattern acceleration/ deceleration - - - With S-pattern acceleration/ deceleration</p> <p>Servo motor speed</p> <p>0 r/min (0 mm/s)</p> <p>RY (n + 1) 0 or RY (n + 1) 1</p> <p>ON OFF</p>	<p>— No S-pattern acceleration/ deceleration - - - With S-pattern acceleration/ deceleration</p> <p>Servo motor speed</p> <p>0 r/min (0 mm/s)</p> <p>RY (n + 1) 0 or RY (n + 1) 1</p> <p>ON OFF</p>	<p>Erases the droop pulse portion and stops the motor. Maintains the home position. However, a difference will be generated between the command position and the current position. Perform a home position return again.</p>	
<p>--- 2</p> <p>— No S-pattern acceleration/ deceleration - - - With S-pattern acceleration/ deceleration</p> <p>Servo motor speed</p> <p>0 r/min (0 mm/s)</p> <p>RY (n + 1) 0 or RY (n + 1) 1</p> <p>ON OFF</p>	<p>— No S-pattern acceleration/ deceleration - - - With S-pattern acceleration/ deceleration</p> <p>Servo motor speed</p> <p>0 r/min (0 mm/s)</p> <p>RY (n + 1) 0 or RY (n + 1) 1</p> <p>ON OFF</p>	<p>Decelerates to a stop with the deceleration time constant currently selected with the point table. Continues operation for a delay portion of the S-pattern acceleration/ deceleration time constants. Maintains the home position. A difference will not be generated between the command position and the current position.</p>	
<p>--- 3</p> <p>— No S-pattern acceleration/ deceleration - - - With S-pattern acceleration/ deceleration</p> <p>Servo motor speed</p> <p>0 r/min (0 mm/s)</p> <p>RY (n + 1) 0 or RY (n + 1) 1</p> <p>ON OFF</p>	<p>— No S-pattern acceleration/ deceleration - - - With S-pattern acceleration/ deceleration</p> <p>Servo motor speed</p> <p>0 r/min (0 mm/s)</p> <p>RY (n + 1) 0 or RY (n + 1) 1</p> <p>ON OFF</p>	<p>Erases the droop pulse portion and stops the motor. Continues operation for a delay portion of the S-pattern acceleration/ deceleration time constants. Maintains the home position. A difference will not be generated between the command position and the current position.</p>	

3. PARAMETERS

3.5 Stop method at software limit detection

Select a stop method of the servo motor for when a software limit ([Pr. PT15] to [Pr. PT18]) is detected with the setting of the third digit in [Pr. PD12]. The software limit limits a command position controlled in the servo amplifier. Therefore, actual stop position will not reach the set position of the software limit.

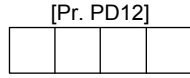

- Stop method selection at software limit detection
- 1: Slow stop
 - 2: Slow stop (deceleration to a stop by deceleration time constant)
 - 3: Quick stop (stop by clearing remaining distance)

[Pr. PD12] setting	Operation status		Remark
	During rotation at constant speed	During deceleration to a stop	
<p>— 1 — (initial value)</p> <p>— No S-pattern acceleration/ deceleration - - - With S-pattern acceleration/ deceleration</p>		<p>Erases the droop pulse portion and stops the motor. Maintains the home position. However, a difference will be generated between the command position and the current position. Perform a home position return again.</p>	
<p>— 2 —</p> <p>— No S-pattern acceleration/ deceleration - - - With S-pattern acceleration/ deceleration</p>		<p>Decelerates to a stop with the deceleration time constant currently selected with the point table. Continues operation for a delay portion of the S-pattern acceleration/ deceleration time constants. Keeps the home position. A difference will not be generated between the command position and the current position.</p>	
<p>— 3 —</p> <p>— No S-pattern acceleration/ deceleration - - - With S-pattern acceleration/ deceleration</p>		<p>Erases the droop pulse portion and stops the motor. Continues operation for a delay portion of the S-pattern acceleration/ deceleration time constants. Keeps the home position. A difference will not be generated between the command position and the current position.</p>	

4. TROUBLESHOOTING

4. TROUBLESHOOTING

POINT	
	<ul style="list-style-type: none"> ● Refer to "MELSERVO-J4 Servo Amplifier Instruction Manual (Troubleshooting)" for details of alarms and warnings. ● As soon as an alarm occurs, make the Servo-off status and interrupt the main circuit power. ● [AL. 37 Parameter error] and warnings (except [AL. F0 Tough drive warning]) are not recorded in the alarm history. ● In the initial setting, [AL. 8D.1 CC-Link IE communication error 1] and [AL. 8D.2 CC-Link IE communication error 2] are not recorded in the alarm history. The alarms are recorded by setting [Pr. PN06] to "___ 1".

When an error occurs during operation, the corresponding alarm and warning are displayed. When an alarm or warning is displayed, refer to "MELSERVO-J4 Servo Amplifier Instruction Manual (Troubleshooting)" to remove the failure. When an alarm occurs, ALM will turn off.

4.1 Explanation for the lists

(1) No./Name/Detail No./Detail name

Indicates each No./Name/Detail No./Detail name of alarms or warnings.

(2) Stop method

For the alarms and warnings in which "SD" is written in the stop method column, the servo motor stops with the dynamic brake after forced stop deceleration. For the alarms and warnings in which "DB" or "EDB" is written in the stop method column, the servo motor stops with the dynamic brake without forced stop deceleration.

(3) Alarm deactivation

After its cause has been removed, the alarm can be deactivated in any of the methods marked ○ in the alarm deactivation column. Warnings are automatically canceled after the cause of occurrence is removed. Alarms are deactivated with alarm reset, CPU reset, or cycling the power.

Alarm deactivation	Explanation
Alarm reset	1. Reset command from controller 2. Pushing the "Occurring Alarm Reset" button in the "Alarm Display" window of MR Configurator2
CPU reset	Resetting the controller itself
Cycling the power	Turning off the power and on again

4. TROUBLESHOOTING

4.2 Alarm list

	No.	Name	Detail No.	Detail name	Stop method (Note 2, 3)	Alarm deactivation		
						Alarm reset	CPU reset	Cycling the power
Alarm	10	Undervoltage	10.1	Voltage drop in the control circuit power	EDB	○	○	○
			10.2	Voltage drop in the main circuit power	SD	○	○	○
	11	Switch setting error	11.1	Axis number setting error/ Station number setting error	DB	/	/	○
			11.2	Disabling control axis setting error	DB	/	/	○
	12	Memory error 1 (RAM)	12.1	RAM error 1	DB	/	/	○
			12.2	RAM error 2	DB	/	/	○
			12.3	RAM error 3	DB	/	/	○
			12.4	RAM error 4	DB	/	/	○
			12.5	RAM error 5	DB	/	/	○
			12.6	RAM error 6	DB	/	/	○
	13	Clock error	13.1	Clock error 1	DB	/	/	○
			13.2	Clock error 2	DB	/	/	○
	14	Control process error	14.1	Control process error 1	DB	/	/	○
			14.2	Control process error 2	DB	/	/	○
			14.3	Control process error 3	DB	/	/	○
			14.4	Control process error 4	DB	/	/	○
			14.5	Control process error 5	DB	/	/	○
			14.6	Control process error 6	DB	/	/	○
			14.7	Control process error 7	DB	/	/	○
			14.8	Control process error 8	DB	/	/	○
			14.9	Control process error 9	DB	/	/	○
			14.A	Control process error 10	DB	/	/	○
			14.B	Control process error 11	DB	/	/	○
	15	Memory error 2 (EEP-ROM)	15.1	EEP-ROM error at power on	DB	/	/	○
			15.2	EEP-ROM error during operation	DB	/	/	○
			15.4	Home position information read error	DB	/	/	○
	16	Encoder initial communication error 1	16.1	Encoder initial communication - Receive data error 1	DB	/	/	○
			16.2	Encoder initial communication - Receive data error 2	DB	/	/	○
			16.3	Encoder initial communication - Receive data error 3	DB	/	/	○
			16.5	Encoder initial communication - Transmission data error 1	DB	/	/	○
			16.6	Encoder initial communication - Transmission data error 2	DB	/	/	○
			16.7	Encoder initial communication - Transmission data error 3	DB	/	/	○
			16.A	Encoder initial communication - Process error 1	DB	/	/	○
			16.B	Encoder initial communication - Process error 2	DB	/	/	○
			16.C	Encoder initial communication - Process error 3	DB	/	/	○
			16.D	Encoder initial communication - Process error 4	DB	/	/	○
			16.E	Encoder initial communication - Process error 5	DB	/	/	○
			16.F	Encoder initial communication - Process error 6	DB	/	/	○

4. TROUBLESHOOTING

	No.	Name	Detail No.	Detail name	Stop method (Note 2, 3)	Alarm deactivation		
						Alarm reset	CPU reset	Cycling the power
Alarm	17	Board error	17.1	Board error 1	DB	<input type="checkbox"/>	<input type="checkbox"/>	<input type="checkbox"/>
			17.3	Board error 2	DB	<input type="checkbox"/>	<input type="checkbox"/>	<input type="checkbox"/>
			17.4	Board error 3	DB	<input type="checkbox"/>	<input type="checkbox"/>	<input type="checkbox"/>
			17.5	Board error 4	DB	<input type="checkbox"/>	<input type="checkbox"/>	<input type="checkbox"/>
			17.6	Board error 5	DB	<input type="checkbox"/>	<input type="checkbox"/>	<input type="checkbox"/>
			17.7	Board error 7	DB	<input type="checkbox"/>	<input type="checkbox"/>	<input type="checkbox"/>
			17.8	Board error 6 (Note 6)	EDB	<input type="checkbox"/>	<input type="checkbox"/>	<input type="checkbox"/>
			17.9	Board error 8	DB	<input type="checkbox"/>	<input type="checkbox"/>	<input type="checkbox"/>
19	Memory error 3 (Flash-ROM)	19.1	Flash-ROM error 1	DB	<input type="checkbox"/>	<input type="checkbox"/>	<input type="checkbox"/>	
		19.2	Flash-ROM error 2	DB	<input type="checkbox"/>	<input type="checkbox"/>	<input type="checkbox"/>	
		19.3	Flash-ROM error 3	DB	<input type="checkbox"/>	<input type="checkbox"/>	<input type="checkbox"/>	
1A	Servo motor combination error	1A.1	Servo motor combination error 1	DB	<input type="checkbox"/>	<input type="checkbox"/>	<input type="checkbox"/>	
		1A.2	Servo motor control mode combination error	DB	<input type="checkbox"/>	<input type="checkbox"/>	<input type="checkbox"/>	
		1A.4	Servo motor combination error 2	DB	<input type="checkbox"/>	<input type="checkbox"/>	<input type="checkbox"/>	
1B	Converter error	1B.1	Converter unit error	DB	<input type="checkbox"/>	<input type="checkbox"/>	<input type="checkbox"/>	
1E	Encoder initial communication error 2	1E.1	Encoder malfunction	DB	<input type="checkbox"/>	<input type="checkbox"/>	<input type="checkbox"/>	
		1E.2	Load-side encoder malfunction	DB	<input type="checkbox"/>	<input type="checkbox"/>	<input type="checkbox"/>	
1F	Encoder initial communication error 3	1F.1	Incompatible encoder	DB	<input type="checkbox"/>	<input type="checkbox"/>	<input type="checkbox"/>	
		1F.2	Incompatible load-side encoder	DB	<input type="checkbox"/>	<input type="checkbox"/>	<input type="checkbox"/>	
20	Encoder normal communication error 1	20.1	Encoder normal communication - Receive data error 1	EDB	<input type="checkbox"/>	<input type="checkbox"/>	<input type="checkbox"/>	
		20.2	Encoder normal communication - Receive data error 2	EDB	<input type="checkbox"/>	<input type="checkbox"/>	<input type="checkbox"/>	
		20.3	Encoder normal communication - Receive data error 3	EDB	<input type="checkbox"/>	<input type="checkbox"/>	<input type="checkbox"/>	
		20.5	Encoder normal communication - Transmission data error 1	EDB	<input type="checkbox"/>	<input type="checkbox"/>	<input type="checkbox"/>	
		20.6	Encoder normal communication - Transmission data error 2	EDB	<input type="checkbox"/>	<input type="checkbox"/>	<input type="checkbox"/>	
		20.7	Encoder normal communication - Transmission data error 3	EDB	<input type="checkbox"/>	<input type="checkbox"/>	<input type="checkbox"/>	
		20.9	Encoder normal communication - Receive data error 4	EDB	<input type="checkbox"/>	<input type="checkbox"/>	<input type="checkbox"/>	
		20.A	Encoder normal communication - Receive data error 5	EDB	<input type="checkbox"/>	<input type="checkbox"/>	<input type="checkbox"/>	
21	Encoder normal communication error 2	21.1	Encoder data error 1	EDB	<input type="checkbox"/>	<input type="checkbox"/>	<input type="checkbox"/>	
		21.2	Encoder data update error	EDB	<input type="checkbox"/>	<input type="checkbox"/>	<input type="checkbox"/>	
		21.3	Encoder data waveform error	EDB	<input type="checkbox"/>	<input type="checkbox"/>	<input type="checkbox"/>	
		21.4	Encoder non-signal error	EDB	<input type="checkbox"/>	<input type="checkbox"/>	<input type="checkbox"/>	
		21.5	Encoder hardware error 1	EDB	<input type="checkbox"/>	<input type="checkbox"/>	<input type="checkbox"/>	
		21.6	Encoder hardware error 2	EDB	<input type="checkbox"/>	<input type="checkbox"/>	<input type="checkbox"/>	
		21.9	Encoder data error 2	EDB	<input type="checkbox"/>	<input type="checkbox"/>	<input type="checkbox"/>	

4. TROUBLESHOOTING

	No.	Name	Detail No.	Detail name	Stop method (Note 2, 3)	Alarm deactivation		
						Alarm reset	CPU reset	Cycling the power
Alarm	24	Main circuit error	24.1	Ground fault detected by hardware detection circuit	DB	<input type="checkbox"/>	<input type="checkbox"/>	<input type="checkbox"/>
			24.2	Ground fault detected by software detection function	DB	<input type="checkbox"/>	<input type="checkbox"/>	<input type="checkbox"/>
	25	Absolute position erased	25.1	Servo motor encoder - Absolute position erased	DB	<input type="checkbox"/>	<input type="checkbox"/>	<input type="checkbox"/>
			25.2	Scale measurement encoder - Absolute position erased	DB	<input type="checkbox"/>	<input type="checkbox"/>	<input type="checkbox"/>
	27	Initial magnetic pole detection error	27.1	Initial magnetic pole detection - Abnormal termination	DB	<input type="checkbox"/>	<input type="checkbox"/>	<input type="checkbox"/>
			27.2	Initial magnetic pole detection - Time out error	DB	<input type="checkbox"/>	<input type="checkbox"/>	<input type="checkbox"/>
			27.3	Initial magnetic pole detection - Limit switch error	DB	<input type="checkbox"/>	<input type="checkbox"/>	<input type="checkbox"/>
			27.4	Initial magnetic pole detection - Estimated error	DB	<input type="checkbox"/>	<input type="checkbox"/>	<input type="checkbox"/>
			27.5	Initial magnetic pole detection - Position deviation error	DB	<input type="checkbox"/>	<input type="checkbox"/>	<input type="checkbox"/>
			27.6	Initial magnetic pole detection - Speed deviation error	DB	<input type="checkbox"/>	<input type="checkbox"/>	<input type="checkbox"/>
			27.7	Initial magnetic pole detection - Current error	DB	<input type="checkbox"/>	<input type="checkbox"/>	<input type="checkbox"/>
	28	Linear encoder error 2	28.1	Linear encoder - Environment error	EDB	<input type="checkbox"/>	<input type="checkbox"/>	<input type="checkbox"/>
	2A	Linear encoder error 1	2A.1	Linear encoder error 1-1	EDB	<input type="checkbox"/>	<input type="checkbox"/>	<input type="checkbox"/>
			2A.2	Linear encoder error 1-2	EDB	<input type="checkbox"/>	<input type="checkbox"/>	<input type="checkbox"/>
			2A.3	Linear encoder error 1-3	EDB	<input type="checkbox"/>	<input type="checkbox"/>	<input type="checkbox"/>
			2A.4	Linear encoder error 1-4	EDB	<input type="checkbox"/>	<input type="checkbox"/>	<input type="checkbox"/>
			2A.5	Linear encoder error 1-5	EDB	<input type="checkbox"/>	<input type="checkbox"/>	<input type="checkbox"/>
			2A.6	Linear encoder error 1-6	EDB	<input type="checkbox"/>	<input type="checkbox"/>	<input type="checkbox"/>
			2A.7	Linear encoder error 1-7	EDB	<input type="checkbox"/>	<input type="checkbox"/>	<input type="checkbox"/>
			2A.8	Linear encoder error 1-8	EDB	<input type="checkbox"/>	<input type="checkbox"/>	<input type="checkbox"/>
	2B	Encoder counter error	2B.1	Encoder counter error 1	EDB	<input type="checkbox"/>	<input type="checkbox"/>	<input type="checkbox"/>
			2B.2	Encoder counter error 2	EDB	<input type="checkbox"/>	<input type="checkbox"/>	<input type="checkbox"/>
	30	Regenerative error	30.1	Regeneration heat error	DB	<input type="checkbox"/> (Note 1)	<input type="checkbox"/> (Note 1)	<input type="checkbox"/> (Note 1)
			30.2	Regeneration signal error	DB	<input type="checkbox"/> (Note 1)	<input type="checkbox"/> (Note 1)	<input type="checkbox"/> (Note 1)
			30.3	Regeneration feedback signal error	DB	<input type="checkbox"/> (Note 1)	<input type="checkbox"/> (Note 1)	<input type="checkbox"/> (Note 1)
	31	Overspeed	31.1	Abnormal motor speed	SD	<input type="checkbox"/>	<input type="checkbox"/>	<input type="checkbox"/>
	32	Overcurrent	32.1	Overcurrent detected at hardware detection circuit (during operation)	DB	<input type="checkbox"/>	<input type="checkbox"/>	<input type="checkbox"/>
			32.2	Overcurrent detected at software detection function (during operation)	DB	<input type="checkbox"/>	<input type="checkbox"/>	<input type="checkbox"/>
			32.3	Overcurrent detected at hardware detection circuit (during a stop)	DB	<input type="checkbox"/>	<input type="checkbox"/>	<input type="checkbox"/>
			32.4	Overcurrent detected at software detection function (during a stop)	DB	<input type="checkbox"/>	<input type="checkbox"/>	<input type="checkbox"/>
	33	Overvoltage	33.1	Main circuit voltage error	EDB	<input type="checkbox"/>	<input type="checkbox"/>	<input type="checkbox"/>

4. TROUBLESHOOTING

	No.	Name	Detail No.	Detail name	Stop method (Note 2, 3)	Alarm deactivation		
						Alarm reset	CPU reset	Cycling the power
Alarm	34	SSCNET receive error 1	34.1	SSCNET receive data error	SD	○	○ (Note 5)	○
			34.2	SSCNET connector connection error	SD	○	○	○
			34.3	SSCNET communication data error	SD	○	○	○
			34.4	Hardware error signal detection	SD	○	○	○
			34.5	SSCNET receive data error (safety observation function)	SD	○	○	○
			34.6	SSCNET communication data error (safety observation function)	SD	○	○	○
	35	Command frequency error	35.1	Command frequency error	SD	○	○	○
	36	SSCNET receive error 2	36.1	Continuous communication data error	SD	○	○	○
			36.2	Continuous communication data error (safety observation function)	SD	○	○	○
	37	Parameter error	37.1	Parameter setting range error	DB	△	○	○
			37.2	Parameter combination error	DB	△	○	○
			37.3	Point table setting error	DB	△	△	○
	39	Program error	39.1	Program error	DB	△	△	○
			39.2	Instruction argument external error	DB	△	△	○
			39.3	Register No. error	DB	△	△	○
			39.4	Non-correspondence instruction error	DB	△	△	○
	3A	Inrush current suppression circuit error	3A.1	Inrush current suppression circuit error	EDB	△	△	○
	3D	Parameter setting error for driver communication	3D.1	Parameter combination error for driver communication on slave	DB	△	△	○
			3D.2	Parameter combination error for driver communication on master	DB	△	△	○
	3E	Operation mode error	3E.1	Operation mode error	DB	△	○	○
			3E.6	Operation mode switch error	DB	△	△	○
	42	Servo control error (for linear servo motor and direct drive motor)	42.1	Servo control error by position deviation	EDB	(Note 4)	(Note 4)	○
			42.2	Servo control error by speed deviation	EDB	(Note 4)	(Note 4)	○
			42.3	Servo control error by torque/thrust deviation	EDB	(Note 4)	(Note 4)	○
		Fully closed loop control error (for fully closed loop control)	42.8	Fully closed loop control error by position deviation	EDB	(Note 4)	(Note 4)	○
			42.9	Fully closed loop control error by speed deviation	EDB	(Note 4)	(Note 4)	○
			42.A	Fully closed loop control error by position deviation during command stop	EDB	(Note 4)	(Note 4)	○
45	Main circuit device overheat	45.1	Main circuit device overheat error 1	SD	○ (Note 1)	○ (Note 1)	○ (Note 1)	
		45.2	Main circuit device overheat error 2	SD	○ (Note 1)	○ (Note 1)	○ (Note 1)	

4. TROUBLESHOOTING

	No.	Name	Detail No.	Detail name	Stop method (Note 2, 3)	Alarm deactivation		
						Alarm reset	CPU reset	Cycling the power
Alarm	46	Servo motor overheat	46.1	Abnormal temperature of servo motor 1	SD	○ (Note 1)	○ (Note 1)	○ (Note 1)
			46.2	Abnormal temperature of servo motor 2	SD	○ (Note 1)	○ (Note 1)	○ (Note 1)
			46.3	Thermistor disconnected error	SD	○ (Note 1)	○ (Note 1)	○ (Note 1)
			46.4	Thermistor circuit error	SD	○ (Note 1)	○ (Note 1)	○ (Note 1)
			46.5	Abnormal temperature of servo motor 3	DB	○ (Note 1)	○ (Note 1)	○ (Note 1)
			46.6	Abnormal temperature of servo motor 4	DB	○ (Note 1)	○ (Note 1)	○ (Note 1)
	47	Cooling fan error	47.1	Cooling fan stop error	SD	△	△	○
			47.2	Cooling fan speed reduction error	SD	△	△	○
	50	Overload 1	50.1	Thermal overload error 1 during operation	SD	○ (Note 1)	○ (Note 1)	○ (Note 1)
			50.2	Thermal overload error 2 during operation	SD	○ (Note 1)	○ (Note 1)	○ (Note 1)
			50.3	Thermal overload error 4 during operation	SD	○ (Note 1)	○ (Note 1)	○ (Note 1)
			50.4	Thermal overload error 1 during a stop	SD	○ (Note 1)	○ (Note 1)	○ (Note 1)
			50.5	Thermal overload error 2 during a stop	SD	○ (Note 1)	○ (Note 1)	○ (Note 1)
			50.6	Thermal overload error 4 during a stop	SD	○ (Note 1)	○ (Note 1)	○ (Note 1)
	51	Overload 2	51.1	Thermal overload error 3 during operation	DB	○ (Note 1)	○ (Note 1)	○ (Note 1)
			51.2	Thermal overload error 3 during a stop	DB	○ (Note 1)	○ (Note 1)	○ (Note 1)
	52	Error excessive	52.1	Excess droop pulse 1	SD	○	○	○
			52.3	Excess droop pulse 2	SD	○	○	○
			52.4	Error excessive during 0 torque limit	SD	○	○	○
			52.5	Excess droop pulse 3	EDB	○	○	○
	54	Oscillation detection	54.1	Oscillation detection error	EDB	○	○	○
	56	Forced stop error	56.2	Over speed during forced stop	EDB	○	○	○
			56.3	Estimated distance over during forced stop	EDB	○	○	○
	61	Operation error	61.1	Point table setting range error	DB	○	△	○
	63	STO timing error	63.1	STO1 off	DB	○	○	○
			63.2	STO2 off	DB	○	○	○
			63.5	STO by functional safety unit	DB	○	○	○
	64	Functional safety unit setting error	64.1	STO input error	DB	△	△	○
			64.2	Compatibility mode setting error	DB	△	△	○
			64.3	Operation mode setting error	DB	△	△	○

4. TROUBLESHOOTING

	No.	Name	Detail No.	Detail name	Stop method (Note 2, 3)	Alarm deactivation		
						Alarm reset	CPU reset	Cycling the power
Alarm	65	Functional safety unit connection error	65.1	Functional safety unit communication error 1	SD	/	/	○
			65.2	Functional safety unit communication error 2	SD	/	/	○
			65.3	Functional safety unit communication error 3	SD	/	/	○
			65.4	Functional safety unit communication error 4	SD	/	/	○
			65.5	Functional safety unit communication error 5	SD	/	/	○
			65.6	Functional safety unit communication error 6	SD	/	/	○
			65.7	Functional safety unit communication error 7	SD	/	/	○
			65.8	Functional safety unit shut-off signal error 1	DB	/	/	○
			65.9	Functional safety unit shut-off signal error 2	DB	/	/	○
	66	Encoder initial communication error (safety observation function)	66.1	Encoder initial communication - Receive data error 1 (safety observation function)	DB	/	/	○
			66.2	Encoder initial communication - Receive data error 2 (safety observation function)	DB	/	/	○
			66.3	Encoder initial communication - Receive data error 3 (safety observation function)	DB	/	/	○
			66.7	Encoder initial communication - Transmission data error 1 (safety observation function)	DB	/	/	○
			66.9	Encoder initial communication - Process error 1 (safety observation function)	DB	/	/	○
	67	Encoder normal communication error 1 (safety observation function)	67.1	Encoder normal communication - Receive data error 1 (safety observation function)	DB	/	/	○
			67.2	Encoder normal communication - Receive data error 2 (safety observation function)	DB	/	/	○
			67.3	Encoder normal communication - Receive data error 3 (safety observation function)	DB	/	/	○
			67.4	Encoder normal communication - Receive data error 4 (safety observation function)	DB	/	/	○
			67.7	Encoder normal communication - Transmission data error 1 (safety observation function)	DB	/	/	○
	68	STO diagnosis error	68.1	Mismatched STO signal error	DB	/	/	○
	69	Command error	69.1	Forward rotation-side software limit detection - Command excess error	SD	○	○	○
			69.2	Reverse rotation-side software limit detection - Command excess error	SD	○	○	○
			69.3	Forward rotation stroke end detection - Command excess error	SD	○	○	○
			69.4	Reverse rotation stroke end detection - Command excess error	SD	○	○	○
			69.5	Upper stroke limit detection - Command excess error	SD	○	○	○
			69.6	Lower stroke limit detection - Command excess error	SD	○	○	○

4. TROUBLESHOOTING

	No.	Name	Detail No.	Detail name	Stop method (Note 2, 3)	Alarm deactivation		
						Alarm reset	CPU reset	Cycling the power
Alarm	70	Load-side encoder initial communication error 1	70.1	Load-side encoder initial communication - Receive data error 1	DB	/	/	○
			70.2	Load-side encoder initial communication - Receive data error 2	DB	/	/	○
			70.3	Load-side encoder initial communication - Receive data error 3	DB	/	/	○
			70.5	Load-side encoder initial communication - Transmission data error 1	DB	/	/	○
			70.6	Load-side encoder initial communication - Transmission data error 2	DB	/	/	○
			70.7	Load-side encoder initial communication - Transmission data error 3	DB	/	/	○
			70.A	Load-side encoder initial communication - Process error 1	DB	/	/	○
			70.B	Load-side encoder initial communication - Process error 2	DB	/	/	○
			70.C	Load-side encoder initial communication - Process error 3	DB	/	/	○
			70.D	Load-side encoder initial communication - Process error 4	DB	/	/	○
			70.E	Load-side encoder initial communication - Process error 5	DB	/	/	○
			70.F	Load-side encoder initial communication - Process error 6	DB	/	/	○
			71	Load-side encoder normal communication error 1	71.1	Load-side encoder normal communication - Receive data error 1	EDB	/
	71.2	Load-side encoder normal communication - Receive data error 2			EDB	/	/	○
	71.3	Load-side encoder normal communication - Receive data error 3			EDB	/	/	○
	71.5	Load-side encoder normal communication - Transmission data error 1			EDB	/	/	○
	71.6	Load-side encoder normal communication - Transmission data error 2			EDB	/	/	○
	71.7	Load-side encoder normal communication - Transmission data error 3			EDB	/	/	○
	71.9	Load-side encoder normal communication - Receive data error 4			EDB	/	/	○
	71.A	Load-side encoder normal communication - Receive data error 5			EDB	/	/	○

4. TROUBLESHOOTING

	No.	Name	Detail No.	Detail name	Stop method (Note 2, 3)	Alarm deactivation		
						Alarm reset	CPU reset	Cycling the power
Alarm	72	Load-side encoder normal communication error 2	72.1	Load-side encoder data error 1	EDB	<input type="checkbox"/>	<input type="checkbox"/>	<input type="checkbox"/>
			72.2	Load-side encoder data update error	EDB	<input type="checkbox"/>	<input type="checkbox"/>	<input type="checkbox"/>
			72.3	Load-side encoder data waveform error	EDB	<input type="checkbox"/>	<input type="checkbox"/>	<input type="checkbox"/>
			72.4	Load-side encoder non-signal error	EDB	<input type="checkbox"/>	<input type="checkbox"/>	<input type="checkbox"/>
			72.5	Load-side encoder hardware error 1	EDB	<input type="checkbox"/>	<input type="checkbox"/>	<input type="checkbox"/>
			72.6	Load-side encoder hardware error 2	EDB	<input type="checkbox"/>	<input type="checkbox"/>	<input type="checkbox"/>
			72.9	Load-side encoder data error 2	EDB	<input type="checkbox"/>	<input type="checkbox"/>	<input type="checkbox"/>
	74	Option card error 1	74.1	Option card error 1	DB	<input type="checkbox"/>	<input type="checkbox"/>	<input type="checkbox"/>
			74.2	Option card error 2	DB	<input type="checkbox"/>	<input type="checkbox"/>	<input type="checkbox"/>
			74.3	Option card error 3	DB	<input type="checkbox"/>	<input type="checkbox"/>	<input type="checkbox"/>
			74.4	Option card error 4	DB	<input type="checkbox"/>	<input type="checkbox"/>	<input type="checkbox"/>
			74.5	Option card error 5	DB	<input type="checkbox"/>	<input type="checkbox"/>	<input type="checkbox"/>
	75	Option card error 2	75.3	Option card connection error	EDB	<input type="checkbox"/>	<input type="checkbox"/>	<input type="checkbox"/>
			75.4	Option card disconnected	DB	<input type="checkbox"/>	<input type="checkbox"/>	<input type="checkbox"/>
	79	Functional safety unit diagnosis error	79.1	Functional safety unit power voltage error	DB	<input type="checkbox"/> (Note 7)	<input type="checkbox"/>	<input type="checkbox"/>
			79.2	Functional safety unit internal error	DB	<input type="checkbox"/>	<input type="checkbox"/>	<input type="checkbox"/>
			79.3	Abnormal temperature of functional safety unit	SD	<input type="checkbox"/> (Note 7)	<input type="checkbox"/>	<input type="checkbox"/>
			79.4	Servo amplifier error	SD	<input type="checkbox"/>	<input type="checkbox"/>	<input type="checkbox"/>
			79.5	Input device error	SD	<input type="checkbox"/>	<input type="checkbox"/>	<input type="checkbox"/>
			79.6	Output device error	SD	<input type="checkbox"/>	<input type="checkbox"/>	<input type="checkbox"/>
			79.7	Mismatched input signal error	SD	<input type="checkbox"/>	<input type="checkbox"/>	<input type="checkbox"/>
			79.8	Position feedback fixing error	DB	<input type="checkbox"/>	<input type="checkbox"/>	<input type="checkbox"/>
	7A	Parameter setting error (safety observation function)	7A.1	Parameter verification error (safety observation function)	DB	<input type="checkbox"/>	<input type="checkbox"/>	<input type="checkbox"/>
			7A.2	Parameter setting range error (safety observation function)	DB	<input type="checkbox"/>	<input type="checkbox"/>	<input type="checkbox"/>
			7A.3	Parameter combination error (safety observation function)	DB	<input type="checkbox"/>	<input type="checkbox"/>	<input type="checkbox"/>
			7A.4	Functional safety unit combination error (safety observation function)	DB	<input type="checkbox"/>	<input type="checkbox"/>	<input type="checkbox"/>
	7B	Encoder diagnosis error (safety observation function)	7B.1	Encoder diagnosis error 1 (safety observation function)	DB	<input type="checkbox"/>	<input type="checkbox"/>	<input type="checkbox"/>
			7B.2	Encoder diagnosis error 2 (safety observation function)	DB	<input type="checkbox"/>	<input type="checkbox"/>	<input type="checkbox"/>
			7B.3	Encoder diagnosis error 3 (safety observation function)	DB	<input type="checkbox"/>	<input type="checkbox"/>	<input type="checkbox"/>
			7B.4	Encoder diagnosis error 4 (safety observation function)	DB	<input type="checkbox"/>	<input type="checkbox"/>	<input type="checkbox"/>
	7C	Functional safety unit communication diagnosis error (safety observation function)	7C.1	Functional safety unit communication cycle error (safety observation function)	SD	<input type="checkbox"/> (Note 7)	<input type="checkbox"/>	<input type="checkbox"/>
			7C.2	Functional safety unit communication data error (safety observation function)	SD	<input type="checkbox"/> (Note 7)	<input type="checkbox"/>	<input type="checkbox"/>
	7D	Safety observation error	7D.1	Stop observation error	DB	<input type="checkbox"/> (Note 3)	<input type="checkbox"/>	<input type="checkbox"/>
7D.2			Speed observation error	DB	<input type="checkbox"/> (Note 7)	<input type="checkbox"/>	<input type="checkbox"/>	
82	Master-slave operation error 1	82.1	Master-slave operation error 1	EDB	<input type="checkbox"/>	<input type="checkbox"/>	<input type="checkbox"/>	

4. TROUBLESHOOTING

	No.	Name	Detail No.	Detail name	Stop method (Note 2, 3)	Alarm deactivation		
						Alarm reset	CPU reset	Cycling the power
Alarm	84	Network module initialization error	84.1	Network module undetected error	DB	/	/	○
			84.2	Network module initialization error 1	DB	/	/	○
			84.3	Network module initialization error 2	DB	/	/	○
	85	Network module error	85.1	Network module error 1	SD	/	/	○
			85.2	Network module error 2	SD	/	/	○
			85.3	Network module error 3	SD	/	/	○
	86	Network communication error	86.1	Network communication error 1	SD	○	/	○
			86.2	Network communication error 2	SD	○	/	○
			86.3	Network communication error 3	SD	○	/	○
	8A	USB communication time-out error/serial communication time-out error/Modbus-RTU communication time-out error	8A.1	USB communication time-out error/serial communication time-out error	SD	○	○	○
			8A.2	Modbus-RTU communication time-out error	SD	○	○	○
	8D	CC-Link IE communication error	8D.1	CC-Link IE communication error 1	SD	○	/	○
			8D.2	CC-Link IE communication error 2	SD	○	/	○
			8D.3	Master station setting error 1	DB	○	/	○
			8D.5	Master station setting error 2	DB	/	/	○
			8D.6	CC-Link IE communication error 3	SD	○	/	○
			8D.7	CC-Link IE communication error 4	SD	○	/	○
			8D.8	CC-Link IE communication error 5	SD	○	/	○
			8D.9	Synchronization error 1	SD	/	/	○
			8D.A	Synchronization error 2	SD	/	/	○
	8E	USB communication error/serial communication error/Modbus-RTU communication error	8E.1	USB communication receive error/serial communication receive error	SD	○	○	○
			8E.2	USB communication checksum error/serial communication checksum error	SD	○	○	○
			8E.3	USB communication character error/serial communication character error	SD	○	○	○
			8E.4	USB communication command error/serial communication command error	SD	○	○	○
			8E.5	USB communication data number error/serial communication data number error	SD	○	○	○
			8E.6	Modbus-RTU communication receive error	SD	○	○	○
			8E.7	Modbus-RTU communication message frame error	SD	○	○	○
8E.8			Modbus-RTU communication CRC error	SD	○	○	○	
88888	Watchdog	8888_	Watchdog	DB	/	/	○	

4. TROUBLESHOOTING

- Note
1. Leave for about 30 minutes of cooling time after removing the cause of occurrence.
 2. The following shows three stop methods of DB, EDB, and SD.

DB: Stops with dynamic brake. (Coasts for the servo amplifier without dynamic brake.)

Coasts for MR-J4-03A6(-RJ) and MR-J4W2-0303B6. Note that EDB is applied when an alarm below occurs;
[AL. 30.1], [AL. 32.2], [AL. 32.4], [AL. 51.1], [AL. 51.2], [AL. 888]

EDB: Electronic dynamic brake stop (available with specified servo motors)

Refer to the following table for the specified servo motors. The stop method for other than the specified servo motors will be DB.

Series	Servo motor
HG-KR	HG-KR053/HG-KR13/HG-KR23/HG-KR43
HG-MR	HG-MR053/HG-MR13/HG-MR23/HG-MR43
HG-SR	HG-SR51/HG-SR52
HG-AK	HG-AK0136/HG-AK0236/HG-AK0336

SD: Forced stop deceleration

3. This is applicable when [Pr. PA04] is set to the initial value. The stop system of SD can be changed to DB using [Pr. PA04].
4. The alarm can be canceled by setting as follows:
For the fully closed loop control: set [Pr. PE03] to "1 ___".
When a linear servo motor or direct drive motor is used: set [Pr. PL04] to "1 ___".
5. In some controller communication status, the alarm factor may not be removed.
6. This alarm will occur only in the J3 compatibility mode.
7. Reset this while all the safety observation functions are stopped.

4. TROUBLESHOOTING

4.3 Warning list

	No.	Name	Detail No.	Detail name	Stop method (Note 2, 3)
Warning	90	Home position return incomplete warning	90.1	Home position return incomplete	
			90.2	Home position return abnormal termination	
			90.5	Z-phase unpassed	
	91	Servo amplifier overheat warning (Note 1)	91.1	Main circuit device overheat warning	
	92	Battery cable disconnection warning	92.1	Encoder battery cable disconnection warning	
			92.3	Battery degradation	
	93	ABS data transfer warning	93.1	ABS data transfer requirement warning during magnetic pole detection	
	95	STO warning	95.1	STO1 off detection	DB
			95.2	STO2 off detection	DB
			95.3	STO warning 1 (safety observation function)	DB
			95.4	STO warning 2 (safety observation function)	DB
			95.5	STO warning 3 (safety observation function)	DB
	96	Home position setting warning	96.1	In-position warning at home positioning	
			96.2	Command input warning at home positioning	
			96.3	Servo off warning at home positioning	
			96.4	Home positioning warning during magnetic pole detection	
	97	Positioning specification warning	97.1	Program operation disabled warning	
			97.2	Next station position warning	
	98	Software limit warning	98.1	Forward rotation-side software stroke limit reached	
			98.2	Reverse rotation-side software stroke limit reached	
	99	Stroke limit warning	99.1	Forward rotation stroke end off	(Note 4, 5)
			99.2	Reverse rotation stroke end off	(Note 4, 5)
			99.4	Upper stroke limit off	(Note 5)
			99.5	Lower stroke limit off	(Note 5)
	9A	Optional unit input data error warning	9A.1	Optional unit input data sign error	
			9A.2	Optional unit BCD input data error	
	9B	Error excessive warning	9B.1	Excess droop pulse 1 warning	
9B.3			Excess droop pulse 2 warning		
9B.4			Error excessive warning during 0 torque limit		
9C	Converter error	9C.1	Converter unit error		
9D	CC-Link IE warning 1	9D.1	Station number switch change warning		
		9D.2	Master station setting warning		
		9D.3	Overlapping station number warning		
		9D.4	Mismatched station number warning		

4. TROUBLESHOOTING

	No.	Name	Detail No.	Detail name	Stop method (Note 2, 3)
Warning	9E	CC-Link IE warning 2	9E.1	CC-Link IE communication warning	
	9F	Battery warning	9F.1	Low battery	
			9F.2	Battery degradation warning	
	E0	Excessive regeneration warning	E0.1	Excessive regeneration warning	
	E1	Overload warning 1	E1.1	Thermal overload warning 1 during operation	
			E1.2	Thermal overload warning 2 during operation	
			E1.3	Thermal overload warning 3 during operation	
			E1.4	Thermal overload warning 4 during operation	
			E1.5	Thermal overload error 1 during a stop	
			E1.6	Thermal overload error 2 during a stop	
			E1.7	Thermal overload error 3 during a stop	
			E1.8	Thermal overload error 4 during a stop	
	E2	Servo motor overheat warning	E2.1	Servo motor temperature warning	
	E3	Absolute position counter warning	E3.1	Multi-revolution counter travel distance excess warning	
			E3.2	Absolute position counter warning	
			E3.4	Absolute positioning counter EEPROM-writing frequency warning	
			E3.5	Encoder absolute positioning counter warning	
	E4	Parameter warning	E4.1	Parameter setting range error warning	
	E5	ABS time-out warning	E5.1	Time-out during ABS data transfer	
			E5.2	ABSM off during ABS data transfer	
			E5.3	SON off during ABS data transfer	
	E6	Servo forced stop warning	E6.1	Forced stop warning	SD
			E6.2	SS1 forced stop warning 1 (safety observation function)	SD
E6.3			SS1 forced stop warning 2 (safety observation function)	SD	
E7	Controller forced stop warning	E7.1	Controller forced stop warning	SD	
E8	Cooling fan speed reduction warning	E8.1	Decreased cooling fan speed warning		
		E8.2	Cooling fan stop		
E9	Main circuit off warning	E9.1	Servo-on signal on during main circuit off	DB	
		E9.2	Bus voltage drop during low speed operation	DB	
		E9.3	Ready-on signal on during main circuit off	DB	
		E9.4	Converter unit forced stop	DB	
EA	ABS servo-on warning	EA.1	ABS servo-on warning		
EB	The other axis error warning	EB.1	The other axis error warning	DB	
EC	Overload warning 2	EC.1	Overload warning 2		

4. TROUBLESHOOTING

	No.	Name	Detail No.	Detail name	Stop method (Note 2, 3)
Warning	ED	Output watt excess warning	ED.1	Output watt excess warning	
	F0	Tough drive warning	F0.1	Instantaneous power failure tough drive warning	
			F0.3	Vibration tough drive warning	
	F2	Drive recorder - Miswriting warning	F2.1	Drive recorder - Area writing time-out warning	
			F2.2	Drive recorder - Data miswriting warning	
	F3	Oscillation detection warning	F3.1	Oscillation detection warning	
	F4	Positioning warning	F4.4	Target position setting range error warning	
			F4.6	Acceleration time constant setting range error warning	
			F4.7	Deceleration time constant setting range error warning	
	F5	Simple cam function - Cam data miswriting warning	F5.1	Cam data - Area writing time-out warning	
			F5.2	Cam data - Area miswriting warning	
			F5.3	Cam data checksum error	
	F6	Simple cam function - Cam control warning	F6.1	Cam axis one cycle current value restoration failed	
			F6.2	Cam axis feed current value restoration failed	
			F6.3	Cam unregistered error	
			F6.4	Cam control data setting range error	
F6.5			Cam No. external error		
F6.6			Cam control inactive		

- Note
1. Leave for about 30 minutes of cooling time after removing the cause of occurrence.
 2. The following shows two stop methods of DB and SD.
DB: Stops with dynamic brake. (Coasts for the servo amplifier without dynamic brake.)
Coasts for MR-J4-03A6(-RJ) and MR-J4W2-0303B6.
SD: Forced stop deceleration
 3. This is applicable when [Pr. PA04] is set to the initial value. The stop system of SD can be changed to DB using [Pr. PA04].
 4. For MR-J4-_A_ servo amplifier, quick stop or slow stop can be selected using [Pr. PD30].
 5. For MR-J4-_GF_ servo amplifier, quick stop or slow stop can be selected using [Pr. PD12]. (I/O mode only)

4. TROUBLESHOOTING

4.4 Troubleshooting at power on

When an error occurs at the power supply of the controller or servo amplifier, improper boot of the servo amplifier might be the cause. Check the display of the servo amplifier, and take actions according to this section.

Display	Description	Cause	Checkpoint	Action
AA	The power of the controller was turned off.	The power of the controller was turned off.	Check the power of the controller.	Switch on the power of the controller.
		An Ethernet cable was disconnected.	"AA" is displayed in the corresponding station and following stations.	Replace the Ethernet cable of the corresponding station.
			Check if the connectors (CNIA, CNIB) are unplugged.	Connect it correctly.
Ab	Initialization communication with the controller has not completed.	An Ethernet cable was disconnected.	"Ab" is displayed in the corresponding station and following stations.	Replace the Ethernet cable of the corresponding station.
		The power of the servo amplifier was switched on when the power of the controller was off.	Check the power of the controller.	Switch on the power of the controller.
		The servo amplifier is malfunctioning.	"Ab" is displayed in the corresponding station and following stations.	Replace the servo amplifier.
		The controller is malfunctioning.	Replace the controller, and then check the repeatability.	Replace the controller.
AC	The synchronous communications by specified cycle could not be made.	The setting of the station No. is incorrect.	Check that a device is not assigned to the same station No.	Set it correctly.
		Station No. does not match with the station No. set to the controller.	Check the controller setting and station No.	Set it correctly.
		The communication cycle does not match.	Check the communication cycle at the controller side.	Set it correctly.
		The servo amplifier parameter setting is incorrect.	Check the following parameter settings. [Pr. PN03] [Pr. PD41]	Set it correctly.
		Data link was established again.	Network configuration was changed.	After checking the network configuration, cycle the power of the servo amplifier.
		The controller setting is incorrect.	Check the controller setting.	Set it correctly.
		The servo amplifier is malfunctioning.	"AC" is displayed in the corresponding station and following stations.	Replace the servo amplifier.
		The controller is malfunctioning.	Replace the controller, and then check the repeatability.	Replace the controller.
b##. C##. d##. (Note)	The system has been in the test operation mode.	Test operation mode has been enabled.	Test operation select switch (SW1-1) is turned on.	Turn off the test operation select switch (SW1-1).
off	Operation mode for manufacturer setting is set.	Operation mode for manufacturer setting is enabled.	Check that the test operation select switch (SW1-1) and manufacturer setting switch (SW1-2) are not on.	Set the auxiliary station number setting switch (SW1) correctly.

Note. ## indicates station No.

REVISION

*The manual number is given on the bottom left of the back cover.

Print Data	*Manual Number	Revision
Feb. 2016	SH(NA)030221-A	First edition

This manual confers no industrial property rights or any rights of any other kind, nor does it confer any patent licenses. Mitsubishi Electric Corporation cannot be held responsible for any problems involving industrial property rights which may occur as a result of using the contents noted in this manual.

Country/Region	Sales office	Tel/Fax
USA	Mitsubishi Electric Automation, Inc. 500 Corporate Woods Parkway, Vernon Hills, IL 60061, U.S.A.	Tel : +1-847-478-2100 Fax : +1-847-478-2253
Mexico	Mitsubishi Electric Automation, Inc. Mexico Branch Mariano Escobedo #69, Col. Zona Industrial, Tlalnepantla Edo. Mexico, C.P.54030	Tel : +52-55-3067-7500 Fax : -
Brazil	Mitsubishi Electric do Brasil Comercio e Servicos Ltda. Avenida Adelino Cardana, 293, 21 andar, Bethaville, CEP 06401-147, Barueri SP, Brazil	Tel : +55-11-4689-3000 Fax : +55-11-4689-3016
Germany	Mitsubishi Electric Europe B.V. German Branch Mitsubishi-Electric-Platz 1, 40882 Ratingen, Germany	Tel : +49-2102-486-0 Fax : +49-2102-486-1120
UK	Mitsubishi Electric Europe B.V. UK Branch Travellers Lane, UK-Hatfield, Hertfordshire, AL10 8XB, U.K.	Tel : +44-1707-28-8780 Fax : +44-1707-27-8695
Italy	Mitsubishi Electric Europe B.V. Italian Branch Centro Direzionale Colleoni - Palazzo Sirio, Viale Colleoni 7, 20864 Agrate Brianza (Milano), Italy	Tel : +39-039-60531 Fax : +39-039-6053-312
Spain	Mitsubishi Electric Europe B.V. Spanish Branch Carretera de Rubi, 76-80-Apdo. 420, 08190 Sant Cugat del Valles (Barcelona), Spain	Tel : +34-935-65-3131 Fax : +34-935-89-1579
France	Mitsubishi Electric Europe B.V. French Branch 25, Boulevard des Bouvets, 92741 Nanterre Cedex, France	Tel : +33-1-55-68-55-68 Fax : +33-1-55-68-57-57
Czech Republic	Mitsubishi Electric Europe B.V. Czech Branch Avenir Business Park, Radlicka 751/113e, 158 00 Praha 5, Czech Republic	Tel : +420-251-551-470 Fax : +420-251-551-471
Poland	Mitsubishi Electric Europe B.V. Polish Branch ul. Krakowska 50, 32-083 Balice, Poland	Tel : +48-12-347-65-00 Fax : +48-12-630-47-01
Russia	Mitsubishi Electric (Russia) LLC St. Petersburg Branch Piskarevsky pr. 2, bld 2, lit "Sch", BC "Benua", office 720; 195027 St. Petersburg, Russia	Tel : +7-812-633-3497 Fax : +7-812-633-3499
Sweden	Mitsubishi Electric Europe B.V. (Scandinavia) Fjelievagen 8, SE-22736 Lund, Sweden	Tel : +46-8-625-10-00 Fax : +46-46-39-70-18
Turkey	Mitsubishi Electric Turkey A.S. Umraniye Branch Serifali Mahallesi Nutuk Sokak No:5, TR-34775 Umraniye / Istanbul, Turkey	Tel : +90-216-526-3990 Fax : +90-216-526-3995
UAE	Mitsubishi Electric Europe B.V. Dubai Branch Dubai Silicon Oasis, P.O.BOX 341241, Dubai, U.A.E.	Tel : +971-4-3724716 Fax : +971-4-3724721
South Africa	Adroit Technologies 20 Waterford Office Park, 189 Witkoppen Road, Fourways, South Africa	Tel : +27-11-658-8100 Fax : +27-11-658-8101
China	Mitsubishi Electric Automation (China) Ltd. Mitsubishi Electric Automation Center, No.1386 Hongqiao Road, Shanghai, China	Tel : +86-21-2322-3030 Fax : +86-21-2322-3000
Taiwan	SETSUYO ENTERPRISE CO., LTD. 6F, No.105, Wugong 3rd Road, Wugu District, New Taipei City 24889, Taiwan	Tel : +886-2-2299-2499 Fax : +886-2-2299-2509
Korea	Mitsubishi Electric Automation Korea Co., Ltd. 7F-9F, Gangseo Hangang Xi-tower A, 401, Yangcheon-ro, Gangseo-Gu, Seoul 07528, Korea	Tel : +82-2-3660-9510 Fax : +82-2-3664-8372/8335
Singapore	Mitsubishi Electric Asia Pte. Ltd. 307 Alexandra Road, Mitsubishi Electric Building, Singapore 159943	Tel : +65-6473-2308 Fax : +65-6476-7439
Thailand	Mitsubishi Electric Factory Automation (Thailand) Co., Ltd. 12th Floor, SV.City Building, Office Tower 1, No. 896/19 and 20 Rama 3 Road, Kwaeng Bangpongpan, Khet Yannawa, Bangkok 10120, Thailand	Tel : +66-2682-6522 to 6531 Fax : +66-2682-6020
Indonesia	PT. Mitsubishi Electric Indonesia Gedung Jaya 11th Floor, JL. MH. Thamrin No.12, Jakarta Pusat 10340, Indonesia	Tel : +62-21-3192-6461 Fax : +62-21-3192-3942
Vietnam	Mitsubishi Electric Vietnam Company Limited Unit 01-04, 10th Floor, Vincom Center, 72 Le Thanh Ton Street, District 1, Ho Chi Minh City, Vietnam	Tel : +84-8-3910-5945 Fax : +84-8-3910-5947
India	Mitsubishi Electric India Pvt. Ltd. Pune Branch Emerald House, EL-3, J Block, M.I.D.C., Bhosari, Pune - 411026, Maharashtra, India	Tel : +91-20-2710-2000 Fax : +91-20-2710-2100
Australia	Mitsubishi Electric Australia Pty. Ltd. 348 Victoria Road, P.O. Box 11, Rydalmere, N.S.W 2116, Australia	Tel : +61-2-9684-7777 Fax : +61-2-9684-7245

MELSERVO and CC-Link IE are trademarks or registered trademarks of Mitsubishi Electric Corporation in Japan and/or other countries.

Ethernet is a trademark of Xerox Corporation.

Modbus is registered trademark of SCHNEIDER ELECTRIC USA, INC.

All other product names and company names are trademarks or registered trademarks of their respective companies.

Warranty

1. Warranty period and coverage

We will repair any failure or defect hereinafter referred to as "failure" in our FA equipment hereinafter referred to as the "Product" arisen during warranty period at no charge due to causes for which we are responsible through the distributor from which you purchased the Product or our service provider. However, we will charge the actual cost of dispatching our engineer for an on-site repair work on request by customer in Japan or overseas countries. We are not responsible for any on-site readjustment and/or trial run that may be required after a defective unit are repaired or replaced.

[Term]

The term of warranty for Product is twelve (12) months after your purchase or delivery of the Product to a place designated by you or eighteen (18) months from the date of manufacture whichever comes first ("Warranty Period"). Warranty period for repaired Product cannot exceed beyond the original warranty period before any repair work.

[Limitations]

- (1) You are requested to conduct an initial failure diagnosis by yourself, as a general rule.
It can also be carried out by us or our service company upon your request and the actual cost will be charged. However, it will not be charged if we are responsible for the cause of the failure.
- (2) This limited warranty applies only when the condition, method, environment, etc. of use are in compliance with the terms and conditions and instructions that are set forth in the instruction manual and user manual for the Product and the caution label affixed to the Product.
- (3) Even during the term of warranty, the repair cost will be charged on you in the following cases;
 - (i) a failure caused by your improper storing or handling, carelessness or negligence, etc., and a failure caused by your hardware or software problem
 - (ii) a failure caused by any alteration, etc. to the Product made on your side without our approval
 - (iii) a failure which may be regarded as avoidable, if your equipment in which the Product is incorporated is equipped with a safety device required by applicable laws and has any function or structure considered to be indispensable according to a common sense in the industry
 - (iv) a failure which may be regarded as avoidable if consumable parts designated in the instruction manual, etc. are duly maintained and replaced
 - (v) any replacement of consumable parts (battery, fan, smoothing capacitor, etc.)
 - (vi) a failure caused by external factors such as inevitable accidents, including without limitation fire and abnormal fluctuation of voltage, and acts of God, including without limitation earthquake, lightning and natural disasters
 - (vii) a failure generated by an unforeseeable cause with a scientific technology that was not available at the time of the shipment of the Product from our company
 - (viii) any other failures which we are not responsible for or which you acknowledge we are not responsible for

2. Term of warranty after the stop of production

- (1) We may accept the repair at charge for another seven (7) years after the production of the product is discontinued. The announcement of the stop of production for each model can be seen in our Sales and Service, etc.
- (2) Please note that the Product (including its spare parts) cannot be ordered after its stop of production.

3. Service in overseas countries

Our regional FA Center in overseas countries will accept the repair work of the Product. However, the terms and conditions of the repair work may differ depending on each FA Center. Please ask your local FA center for details.

4. Exclusion of loss in opportunity and secondary loss from warranty liability

Regardless of the gratis warranty term, Mitsubishi shall not be liable for compensation to:

- (1) Damages caused by any cause found not to be the responsibility of Mitsubishi.
- (2) Loss in opportunity, lost profits incurred to the user by Failures of Mitsubishi products.
- (3) Special damages and secondary damages whether foreseeable or not, compensation for accidents, and compensation for damages to products other than Mitsubishi products.
- (4) Replacement by the user, maintenance of on-site equipment, start-up test run and other tasks.

5. Change of Product specifications

Specifications listed in our catalogs, manuals or technical documents may be changed without notice.

6. Application and use of the Product

- (1) For the use of our General-Purpose AC Servo, its applications should be those that may not result in a serious damage even if any failure or malfunction occurs in General-Purpose AC Servo, and a backup or fail-safe function should operate on an external system to General-Purpose AC Servo when any failure or malfunction occurs.
- (2) Our General-Purpose AC Servo is designed and manufactured as a general purpose product for use at general industries. Therefore, applications substantially influential on the public interest for such as atomic power plants and other power plants of electric power companies, and also which require a special quality assurance system, including applications for railway companies and government or public offices are not recommended, and we assume no responsibility for any failure caused by these applications when used
In addition, applications which may be substantially influential to human lives or properties for such as airlines, medical treatments, railway service, incineration and fuel systems, man-operated material handling equipment, entertainment machines, safety machines, etc. are not recommended, and we assume no responsibility for any failure caused by these applications when used. We will review the acceptability of the abovementioned applications, if you agree not to require a specific quality for a specific application. Please contact us for consultation.

MODEL	MR-J4-GF-(RJ) INSTRUCTIONMANUAL(10 MODE)
MODEL CODE	1CW863

MITSUBISHI ELECTRIC CORPORATION

HEAD OFFICE : TOKYO BLDG MARUNOUCHI TOKYO 100-8310