

AJ65SBTB32-16KDR 形 CC-Link システム小形タイプリモート I/O ユニットユーザーズマニュアル AJ65SBTB32-16KDR CC-Link System Compact Type Remote I/O Module User's Manual

● 安全上のご注意 ● (ご使用前に必ずお読みください)

本製品のご使用に際しては、本マニュアルをよくお読みいただくと共に、安全に対して十分に注意を払って、正しい取扱いをしていただくようお願いいたします。

なお、この注意事項は本製品に関するもののみについて記載したものです。シーケンサシステムとしての安全上のご注意に関しては、CPUユニットのユーザーズマニュアルを参照してください。

この●安全上のご注意●では、安全注意事項のランクを「危険」、「注意」として区分してあります。

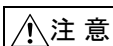
 危険	取扱いを誤った場合に、危険な状況が起こりえて、死亡または重傷を受ける可能性が想定される場合。
 注意	取扱いを誤った場合に、危険な状況が起こりえて、中程度の傷害や軽傷を受ける可能性が想定される場合および物的損害だけの発生が想定される場合。

なお、△注意に記載した事項でも、状況によっては重大な結果に結びつく可能性があります。
 いずれも重要な内容を記載していますので必ず守ってください。
 本マニュアルは必要ときに読んでいただくように大切に保管すると共に、必ず最終ユーザまでお届けいただくようお願いいたします。

【設計上の注意事項】

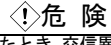
 危険	<ul style="list-style-type: none"> データリンクが通信異常になったとき、通信異常時は次のような状態になります。通信状態情報を使って、システムが安全側に動くようにシーケンスプログラム上でインタロック回路を構成してください。 誤出力、誤動作により事故の恐れがあります。 (1) リモート I/O 局からの入力は、全点 OFF します。 (2) リモート I/O 局からの出力は、全点 OFF します。 リモート I/O ユニットの故障によっては、入出力が ON 状態または OFF 状態になることがあります。重大な事故につながるような入出力信号については、外部で監視する回路を設けてください。
---	---

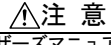
 注意	<ul style="list-style-type: none"> ユニットは、CPU ユニットユーザーズマニュアル記載の一般仕様の環境で使用してください。一般仕様の範囲以外の環境で使用すると、感電、火災、誤動作、製品の損傷あるいは劣化の原因になります。 制御線や通信ケーブルは、主回路や動力線などと束線したり、近接したりしないでください。 100mm 以上を目安として離してください。 ノイズにより、誤動作の原因になります。
---	--

【取付け上の注意事項】

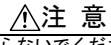
 注意	<ul style="list-style-type: none"> ユニットの導電部分には直接触らないでください。ユニットの誤動作、故障の原因になります。 ユニットは、DIN レールまたは取付けネジにて、確実に固定し、取付けネジは規定トルク範囲内で確実に締め付けてください。 ネジの締め付けがゆるいと、落下、短絡、誤動作の原因になります。ネジを締め過ぎると、ネジの破損による落下、短絡の原因になります。
---	--

【配線上の注意事項】

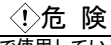
 危険	<ul style="list-style-type: none"> 配線作業などは、必ずシステムで使用している外部供給電源を全相遮断してから行ってください。全相遮断しないと、感電あるいは製品の損傷の恐れがあります。
---	---

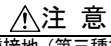
 注意	<ul style="list-style-type: none"> FG 端子はシーケンサ専用の D 種接地（第三種接地）以上で必ず接地を行ってください。感電、誤動作の恐れがあります。 空き端子ネジは必ず締め付けトルク範囲（42~50N・cm）で締め付けてください。圧着端子と短絡の原因になります。 圧着端子は適合圧着端子を使用し、規定のトルクで締め付けてください。先開形圧着端子を使用すると、端子ネジがゆるんだ場合に脱落し、故障の原因になります。 ユニットの配線は、製品の定格電圧および端子配列を確認した上で正しく行ってください。定格と異なった電源を接続したり、誤配線すると、火災、故障の原因になります。 端子ネジの締め付けは、規定トルク範囲内で行ってください。端子ネジの締め付けがゆるいと、火災や誤動作の原因になります。端子ネジを締め過ぎると、ネジの破損による短絡、誤動作の原因になります。 ユニット内に、切粉や配線クズなどの異物が入らないように注意してください。火災、故障、誤動作の原因になります。 ユニットに接続する電線やケーブルは、必ずダクトに納める、またはクランプによる固定処理を行ってください。ケーブルをダクトに納めなかったり、クランプによる固定処理をしていないと、ケーブルのブラツキや移動、不注意の引っ張りなどによるユニットやケーブルの破損、ケーブルの接触不良による誤動作の原因となります。 制御線や通信ケーブルは束線したり、近接したりしないでください。ノイズにより、誤動作の原因になります。 ユニットに接続されたケーブルを取り外すときは、ケーブル部分を手に持って引っ張らないでください。コネクタ付きのケーブルは、ユニットに接続している部分のコネクタを手で持って取り外してください。コネクタなしのケーブルは、ユニットに接続している部分のネジを緩めてから取り外してください。ユニットに接続された状態でケーブルを引っ張ると、ユニットやケーブルの破損、ケーブルの接続不良による誤動作の原因となります。
---	---

● SAFETY PRECAUTIONS ● (Read these precautions before using.)

When using this equipment, thoroughly read this manual. Also pay careful attention to safety and handle the module properly.

These precautions apply only to this equipment. Refer to the CPU module user's manual for a description of the PC system safety precautions.

These ●SAFETY PRECAUTIONS● classify the safety precautions into two categories: "DANGER" and "CAUTION".

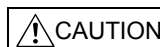
 DANGER	Procedures which may lead to a dangerous condition and cause death or serious injury if not carried out properly.
 CAUTION	Procedures which may lead to a dangerous condition and cause superficial to medium injury, or physical damage only, if not carried out properly.

Depending on circumstances, procedures indicated by △ CAUTION may also result in serious results.

In any case, it is important to follow the directions for usage.

Store this manual in a safe place so that you can take it out and read it whenever necessary. Always forward it to the end user.

(0710) MEE

【DESIGN PRECATUIONS】

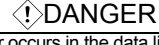
 DANGER	<ul style="list-style-type: none"> When a communication error occurs in the data link, the communication error station will be in the following condition. Configure an interlocking circuit in a sequence program using the communication status information so that the safety of the overall system is always maintained. Accident may occur due to output error or malfunction. (1) Input points from remote I/O station will be all switched off. (2) Output points from remote I/O station will be all switched off. I/O could be switched on or off when a problem occurs in the remote I/O modules. So build an external monitoring circuit that will monitor any I/O signals that could cause a serious accident.
---	--

 CAUTION	<ul style="list-style-type: none"> Use each module in an environment as specified in the "general specification" in the CPU module user's manual. Usage of the module outside the general specification range may cause electric shock, fire, malfunction, product damage or deterioration. Do not have control cables and communication cables bundled with or placed near by the main circuit and/or power cables. Wire those cables at least 100mm(3.94 inch) away from the main circuit and/or power cables. It may cause malfunction due to noise interference.
--	--

【INSTALLATION PRECAUTIONS】

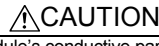
 CAUTION	<ul style="list-style-type: none"> Do not directly touch the module's conductive parts. Doing so could cause malfunction or trouble in the module. Tighten the module securely using DIN rail or installation screws within the specified torque range. Loose terminal screws may cause a short circuit or erroneous operation. If the terminal screws are too tight, it may cause falling, short circuit or erroneous operation due to damage of the screws.
--	---

【WIRING PRECAUTIONS】

 DANGER	<ul style="list-style-type: none"> Completely turn off the externally supplied power used in the system when installing or placing wiring. Not completely turning off all power could result in electric shock or damage to the product.
---	---

 CAUTION	<ul style="list-style-type: none"> Always ground the FG terminal. There is a risk of electric shock or malfunction. Be sure to tighten any unused terminal screws within a tightening torque range (42 to 50N・cm). Failure to do so may cause a short circuit due to contact with a solderless terminal. Use applicable solderless terminals and tighten them with the specified torque. If any solderless spade terminal is used, it may be disconnected when the terminal screw comes loose, resulting in failure. Perform correct wiring for the module according to the product's rated voltage and terminal arrangement. Connecting to a power supply different from rating or miss-wiring may cause fire and/or product failure. Fix terminal screws securely within the regulated torque. Loose terminal screws may cause fire and/or malfunction. If the terminal screws are too tight, it may cause short circuit or erroneous operation due to damage of the screws. Make sure foreign objects do not get inside the module, such as dirt and wire chips. It may cause fire, product failure or malfunction. Be sure to fix the wires or cables by ducts or clamps when connecting them to the module. Failure to do so may cause damage of the module or the cables due to accidental pull or unintentional shifting of the cables, or malfunctions due to poor contact of the cable. Do not install the control lines together with the communication cables, or bring them close to each other. Failure to do so may cause malfunctions due to noise. When disconnecting a cable from the module, do not pull on the cable itself. Disconnect cables not fitted with a connectors by holding and pulling the cable connector. Disconnect cables not fitted with a connector by removing the screws from the part connected to the module can cause damage to the module or cable, or malfunction due to cable connection faults.
--	--

【立上げ・保守時の注意事項】

⚠危険
<ul style="list-style-type: none"> ● 通電中に端子に触れないでください。感電の原因になります。 ● 清掃、端子ネジ、ユニット取付けネジの増し締めは、必ずシステムで使用している外部供給電源を全相遮断してから行ってください。全相遮断しないと、ユニットの故障や誤動作の原因になります。

⚠注意
<ul style="list-style-type: none"> ● ユニットの分解、改造はしないでください。故障、誤動作、ケガ、火災の原因になります。 ● ユニットの落下させたり、強い衝撃を与えないでください。ユニットの破損の原因になります。 ● ユニットの盤への取付け・取外しは必ずシステムで使用している外部供給電源を全相遮断してから行ってください。全相遮断しないと、ユニットの故障や誤動作の原因になります。 ● 端子台の着脱は、製品ご使用後、50回以内としてください。(JIS B 3502 準拠) ● ユニットの触れる前には、必ず接地された金属などに触れて、人体などに帯電している静電気を放電してください。静電気を放電しないと、ユニットの故障や誤動作の原因になります。

【廃棄時の注意事項】

⚠注意
● 製品を廃棄するときは、産業廃棄物として扱ってください。

1. 仕様

項目		内容					
入力部	入力点数	8点					
	絶縁方式	フォトカブラ絶縁					
	定格入力電圧	DC24V					
	定格入力電流	約 7mA					
	使用電圧範囲	DC20.4~28.8V (リップル率 5%以内)					
	最大同時入力点数	100%					
	ON電圧/ON電流	14V以上/4mA以上					
	OFF電圧/OFF電流	5.5V以下/1.7mA以下					
	入力抵抗	約 3.0kΩ					
	応答時間	入力応答速度	0.2ms	1.5ms	5ms	10ms	
	OFF→ON	0.2ms以下	1.5ms以下	5ms以下	10ms以下		
	ON→OFF	0.2ms以下	1.5ms以下	5ms以下	10ms以下		
コモン方式	8点1コモン (端子台形3線式)						
入力形式	プラス、マイナスコモン共用タイプ (シンク、ソース共用タイプ)						
出力部	出力点数	8点					
	絶縁方式	リレー絶縁					
	定格負荷電圧	DC24V (抵抗負荷) AC240V (cosφ=1) 2A/1点 4A/1コモン					
	同時ON点数	全点					
	最小開閉負荷	DC5V/1mA					
	最大開閉電圧	AC264V DC125V					
	寿命	電氣的	機械的	2000回以上			
			電氣的	定格開閉電圧・電流負荷	10万回以上		
			AC200V 1.5A, AC240V 1A (cosφ=0.7)	10万回以上			
			DC24V 1A, DC100V 0.1A (L/R=7ms)	10万回以上			
最大開閉頻度	3600回/時						
応答時間	OFF→ON	10ms以下					
	ON→OFF	12ms以下					
コモン方式	4点1コモン (端子台形2線式)						
サージキラー	なし						
占有局数	1局 32点割付け (16点使用)						
I/Oユニット電源	電圧	DC20.4~26.4V (リップル率 5%以内)					
	電流	100mA以下 (DC24V, 全点ON時)					
ノイズ耐量	ACタイプのノイズ電圧 1500Vp-p, DCタイプのノイズ電圧 500Vp-p, ノイズ幅 1μs, ノイズ周波数 25~60Hz のノイズシミュレータによる						
耐電圧	AC 外部機器一括アース間 AC2830V rms/3サイクル (標高 2000m) DC 外部端子一括アース間 AC500V 1分間						
絶縁抵抗	AC 外部端子一括アース間 DC500V 絶縁抵抗計にて 10MΩ以上 DC 外部端子一括アース間 DC500V 絶縁抵抗計にて 10MΩ以上						
保護等級	IP1X						
質量	0.29kg						
外部接続方式	通信部, I/Oユニット電源部	7点2ピース端子台 [伝送回路, I/Oユニット電源, FG] M3×5.2 締付けトルク範囲: 59~88N・cm 適合圧着端子の挿入枚数は2枚以内					
	入出力電源部, 入出力部	34点直付け端子台 [入出力電源, I/O信号] M3×5.2 締付けトルク範囲: 59~88N・cm 適合圧着端子の挿入枚数は2枚以内					
ユニット取付けネジ	平座金みがき丸付 M4 ネジ (締付けトルク範囲: 79~108N・cm) DIN レールでの取付け可, 6方向取付け可						
適用 DIN レール	TH35-7.5Fe, TH35-7.5Al (JIS C 2812に準拠)						
適合圧着端子	<ul style="list-style-type: none"> ● RAV1.25-3 (JIS C 2805に準拠) [適合電線サイズ: 0.3~1.25mm²] ● V2-MS3 (日本圧着端子製造(株)), RAP2-3SL (日本端子(株)), TGV2-3N ((株)ニチフ) [適合電線サイズ: 1.25~2.0mm²] 						

【STARTING AND MAINTENANCE PRECAUTIONS】

⚠DANGER
<ul style="list-style-type: none"> ● Do not touch terminals when the power is on. Doing so could cause an electric shock. ● Switch off all phases of the externally supplied power used in the system when cleaning the module or retightening the terminal or module mounting screws. Not doing so could result in electric shock.

⚠CAUTION
<ul style="list-style-type: none"> ● Never try to disassemble or modify module. It may cause product failure, malfunction, fire or cause injury. ● Do not drop or apply any strong impact to the module. Doing so may damage the module. ● Completely turn off the externally supplied power used in the system before mounting or removing the module to/from the panel. Not doing so could result in damage to the product. ● Mounting/removing the terminal block is limited to 50 times after using a product. (IEC61131-2-compliant) ● Always make sure to touch the grounded metal to discharge the electricity charged in the electricity charged in the body, etc., before touching the module. Failure to do so may cause a failure or malfunctions of the module.

【DISPOSAL PRECAUTIONS】

⚠CAUTION
● When disposing of this product, treat it as industrial waste.

1. Specification

Item	Description					
Number of output points	8 points					
Isolation method	Photocoupler					
Rated input voltage	24 V DC					
Rated input current	Approx. 7 mA					
Operating voltage range	20.4 to 28.8 V DC (ripple ratio: within 5 %)					
Max. simultaneous ON input points	100 %					
ON voltage/ON current	14 V or higher/4 mA or higher					
OFF voltage/OFF current	5.5 V or lower/1.7 mA or lower					
Input resistance	Approx. 3.0 kΩ					
Response time	Input response speed	0.2 ms	1.5 ms	5 ms	10 ms	
		OFF→ON	0.2 ms or lower	1.5 ms or lower	5 ms or lower	10 ms or lower
		ON→OFF	0.2 ms or lower	1.5 ms or lower	5 ms or lower	10 ms or lower
Wiring method for common	8 points/common (terminal block 3-wire type)					
Input form	Positive/Negative common shared type (sink/source shared type)					
Number of output points	8 points					
Isolation method	Relay					
Rated load voltage	24 V DC (resistive load) 240 V AC (cosφ=1) 2 A/point 4 A/common					
Number of simultaneous ON points	All points					
Min. open/close load	5 V DC/1 mA					
Max. switching voltage	264 V AC 125 V DC					
Service life	Mechanical	More than 20 million times				
	Electrical	Rated switching voltage/current loads 100 thousand times or more 200 V AC 1.5 A, 240 V AC 1 A (cosφ=0.7): 100 thousand times or more 200 V AC 1 A, 240 V AC 0.5 A (cosφ=0.35): 100 thousand times or more 24 V DC 1 A, 100 V DC 0.1 A (L/R=7ms): 100 thousand times or more				
Max. switching frequency	3600 times/hour					
Response time	OFF→ON	10 ms or lower				
		ON→OFF	12 ms or lower			
Wiring method for common	4 points/common (terminal block 2-wire type)					
Surge suppression	None					
Number of stations occupied	1 station 32 points assignment (use 16 points)					
I/O module power supply	Voltage	20.4 to 26.4 V DC (ripple ratio: within 5 %)				
	Current	100 mA or lower (when 24 V DC, all points ON)				
Noise durability	AC type noise voltage 1500 Vp-p, DC type noise voltage 500 Vp-p, noise width 1 μs, noise carrier frequency 25 to 60 Hz (noise simulator condition)					
Withstand voltage	2830 V AC rms/3 cycles between all AC external terminals and ground (2000 m above sea level) 500 V AC for 1 minute between all DC external terminals and ground					
Insulation resistance	10 MΩ or higher, measured with a 500 V DC insulation resistance tester between all AC external terminals and ground 10 MΩ or higher, measured with a 500 V DC insulation resistance tester between all DC external terminals and ground					
Protection of degree	IP1X					
Weight	0.29 kg					
External wiring system	Communication part, I/O module power supply part	7-point terminal block (two-piece) [Transmission circuit, I/O module power supply, FG] M3×5.2 Tightening torque range: 59 to 88 N·cm Applicable solderless terminals: 2 max.				
	I/O power supply, I/O part	34-point direct-mount terminal block [I/O power supply, I/O signal] M3×5.2 Tightening torque range: 59 to 88 N·cm Applicable solderless terminals: 2 max.				
Module mounting screw	M4 screw with plain washer finished round (tightening torque range: 79 to 108 N·cm) Module can be mounted using DIN rail and can be mounted in 6 directions					
Applicable DIN rail	TH35-7.5Fe, TH35-7.5Al (conforming to IEC 60715)					
Applicable solderless terminal	<ul style="list-style-type: none"> ● RAV1.25-3 (conforming to JIS C 2805) [Applicable wire size: 0.3 to 1.25 mm²] ● V2-MS3, RAP2-3SL, TGV2-3N [Applicable wire size: 1.25 to 2.0 mm²] 					

外部接続 (External connection)

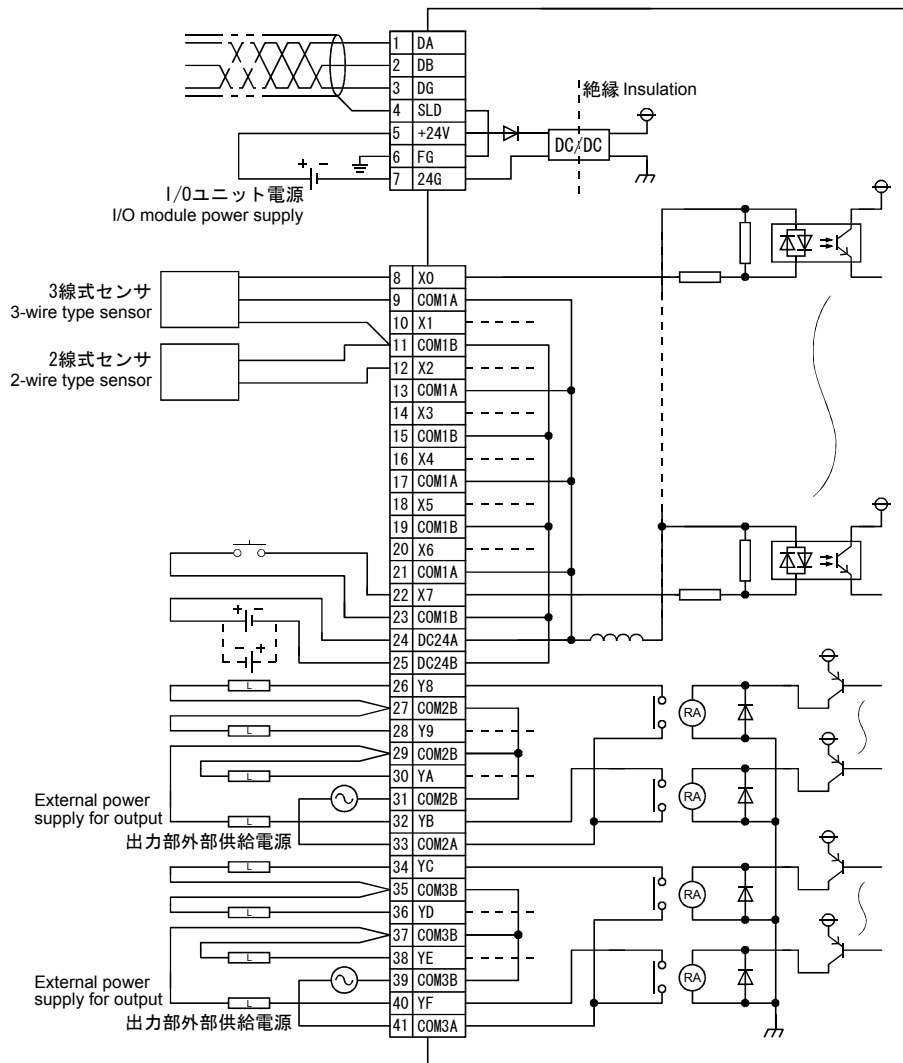

端子番号 Terminal number	信号名 Signal name
TB1	DA
TB2	DB
TB3	DG
TB4	SLD
TB5	+24V
TB6	△ (FG)
TB7	24G
TB8	X0
TB9	COM1A
TB10	X1
TB11	COM1B
TB12	X2
TB13	COM1A
TB14	X3
TB15	COM1B
TB16	X4
TB17	COM1A
TB18	X5
TB19	COM1B
TB20	X6
TB21	COM1A
TB22	X7
TB23	COM1B
TB24	DC24A
TB25	DC24B
TB26	Y8
TB27	COM2B
TB28	Y9
TB29	COM2B
TB30	YA
TB31	COM2B
TB32	YB
TB33	COM2A
TB34	YC
TB35	COM3B
TB36	YD
TB37	COM3B
TB38	YE
TB39	COM3B
TB40	YF
TB41	COM3A

2. 各部の名称と設定

2. Part Names and Settings

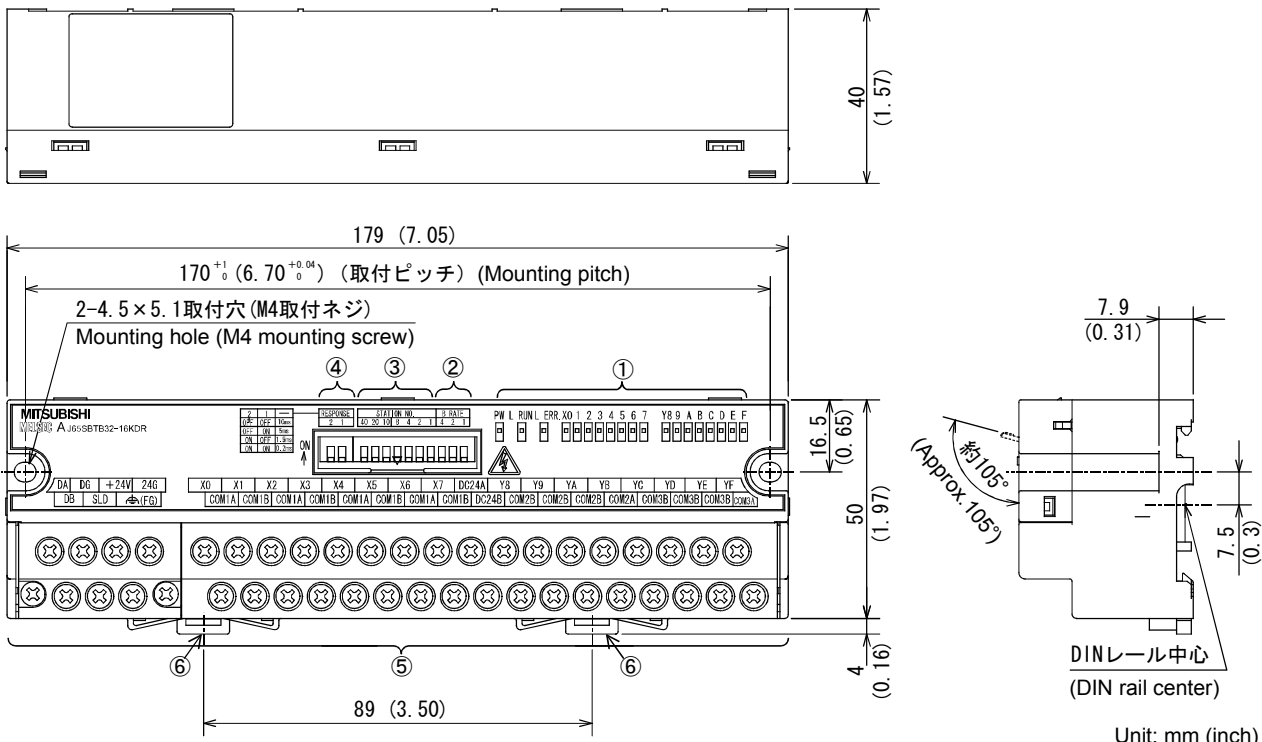

Unit: mm (inch)

No.	名称	内容																																	
①	動作表示 LED	<table border="1"> <thead> <tr> <th>LED名</th> <th>確認内容</th> </tr> </thead> <tbody> <tr> <td>PW</td> <td>点灯: 電源ON 消灯: 電源OFF</td> </tr> <tr> <td>L RUN</td> <td>点灯: 交信正常時 消灯: 交信断時 (タイムオーバーエラー)</td> </tr> <tr> <td>L ERR.</td> <td>点灯: 交信エラー時 一定間隔で点滅: 通電中に局番設定/伝送速度設定スイッチの設定を変更したとき 不定間隔で点滅: 終端抵抗の設定が違っているとき ユニット, CC-Link専用ケーブルがノイズの影響を受けているとき 消灯: 交信正常時</td> </tr> <tr> <td>X0~7 Y8~F</td> <td>点灯: 入出力ON 消灯: 入出力OFF</td> </tr> </tbody> </table>	LED名	確認内容	PW	点灯: 電源ON 消灯: 電源OFF	L RUN	点灯: 交信正常時 消灯: 交信断時 (タイムオーバーエラー)	L ERR.	点灯: 交信エラー時 一定間隔で点滅: 通電中に局番設定/伝送速度設定スイッチの設定を変更したとき 不定間隔で点滅: 終端抵抗の設定が違っているとき ユニット, CC-Link専用ケーブルがノイズの影響を受けているとき 消灯: 交信正常時	X0~7 Y8~F	点灯: 入出力ON 消灯: 入出力OFF																							
		LED名	確認内容																																
		PW	点灯: 電源ON 消灯: 電源OFF																																
		L RUN	点灯: 交信正常時 消灯: 交信断時 (タイムオーバーエラー)																																
L ERR.	点灯: 交信エラー時 一定間隔で点滅: 通電中に局番設定/伝送速度設定スイッチの設定を変更したとき 不定間隔で点滅: 終端抵抗の設定が違っているとき ユニット, CC-Link専用ケーブルがノイズの影響を受けているとき 消灯: 交信正常時																																		
X0~7 Y8~F	点灯: 入出力ON 消灯: 入出力OFF																																		
②	伝送速度設定	<table border="1"> <thead> <tr> <th rowspan="2">設定値</th> <th colspan="3">設定スイッチ状態</th> <th rowspan="2">伝送速度</th> </tr> <tr> <th>4</th> <th>2</th> <th>1</th> </tr> </thead> <tbody> <tr> <td>0</td> <td>OFF</td> <td>OFF</td> <td>OFF</td> <td>156 kbps</td> </tr> <tr> <td>1</td> <td>OFF</td> <td>OFF</td> <td>ON</td> <td>625 kbps</td> </tr> <tr> <td>2</td> <td>OFF</td> <td>ON</td> <td>OFF</td> <td>2.5 Mbps</td> </tr> <tr> <td>3</td> <td>OFF</td> <td>ON</td> <td>ON</td> <td>5.0 Mbps</td> </tr> <tr> <td>4</td> <td>ON</td> <td>OFF</td> <td>OFF</td> <td>10 Mbps</td> </tr> </tbody> </table> <p>伝送速度は必ず上記の範囲で設定してください。</p>	設定値	設定スイッチ状態			伝送速度	4	2	1	0	OFF	OFF	OFF	156 kbps	1	OFF	OFF	ON	625 kbps	2	OFF	ON	OFF	2.5 Mbps	3	OFF	ON	ON	5.0 Mbps	4	ON	OFF	OFF	10 Mbps
設定値	設定スイッチ状態			伝送速度																															
	4	2	1																																
0	OFF	OFF	OFF	156 kbps																															
1	OFF	OFF	ON	625 kbps																															
2	OFF	ON	OFF	2.5 Mbps																															
3	OFF	ON	ON	5.0 Mbps																															
4	ON	OFF	OFF	10 Mbps																															
③	局番設定スイッチ	<p>STATION NO. の “10”, “20”, “40” で局番の10の位を設定します。 STATION NO. の “1”, “2”, “4”, “8” で局番の1の位を設定します。 局番は必ず1~64の範囲で設定してください。(*1)</p> <p>(例) 局番を “32” に設定するときは, 下記のようにスイッチ設定を行います。</p> <table border="1"> <thead> <tr> <th rowspan="2">局番</th> <th colspan="3">十の位</th> <th colspan="4">一の位</th> </tr> <tr> <th>40</th> <th>20</th> <th>10</th> <th>8</th> <th>4</th> <th>2</th> <th>1</th> </tr> </thead> <tbody> <tr> <td>32</td> <td>OFF</td> <td>ON</td> <td>ON</td> <td>OFF</td> <td>OFF</td> <td>ON</td> <td>OFF</td> </tr> </tbody> </table>	局番	十の位			一の位				40	20	10	8	4	2	1	32	OFF	ON	ON	OFF	OFF	ON	OFF										
局番	十の位			一の位																															
	40	20	10	8	4	2	1																												
32	OFF	ON	ON	OFF	OFF	ON	OFF																												
④	入力応答速度切替スイッチ	<table border="1"> <thead> <tr> <th rowspan="2">設定値</th> <th colspan="2">設定スイッチ状態</th> <th rowspan="2">入力応答速度</th> </tr> <tr> <th>2</th> <th>1</th> </tr> </thead> <tbody> <tr> <td>0</td> <td>OFF</td> <td>OFF</td> <td>10ms</td> </tr> <tr> <td>1</td> <td>OFF</td> <td>ON</td> <td>5ms</td> </tr> <tr> <td>2</td> <td>ON</td> <td>OFF</td> <td>1.5ms</td> </tr> <tr> <td>3</td> <td>ON</td> <td>ON</td> <td>0.2ms</td> </tr> </tbody> </table> <p>出荷時の設定は, “2” の “1.5ms” です。(*2)</p>	設定値	設定スイッチ状態		入力応答速度	2	1	0	OFF	OFF	10ms	1	OFF	ON	5ms	2	ON	OFF	1.5ms	3	ON	ON	0.2ms											
設定値	設定スイッチ状態			入力応答速度																															
	2	1																																	
0	OFF	OFF	10ms																																
1	OFF	ON	5ms																																
2	ON	OFF	1.5ms																																
3	ON	ON	0.2ms																																
⑤	端子台	入出力ユニット電源, 伝送, 入出力信号の接続用端子台です。																																	
⑥	DIN レール用フック	ユニットをDINレールに取り付けるときにDINレール用フックの中心線上を指でカチッと音がするまで押さえます。																																	

*1: 局番は重複して設定できません。

*2: スwitchの設定内容は, 電源投入により反映・保持されます。通電中にスイッチ設定を変更した場合は, 電源の再投入が必要です。

No.	Item	Description																																	
①	Operating status indicator LEDs	<table border="1"> <thead> <tr> <th>LED name</th> <th>Confirmation details</th> </tr> </thead> <tbody> <tr> <td>PW</td> <td>ON: Power supply ON OFF: Power supply OFF</td> </tr> <tr> <td>L RUN</td> <td>ON: Normal communication OFF: Communication shut off (time expiration error)</td> </tr> <tr> <td>L ERR.</td> <td>ON: Communication data error Flash at regular intervals: Indicates that the station number setting or transmission speed setting switch position was changed while power is ON Flash at irregular intervals: When the setting of the terminal resistor is wrong; when the cable for the module or CC-Link is affected by noise OFF: Normal communication</td> </tr> <tr> <td>X0 to 7 Y8 to F</td> <td>ON: Input/Output ON OFF: Input/Output OFF</td> </tr> </tbody> </table>	LED name	Confirmation details	PW	ON: Power supply ON OFF: Power supply OFF	L RUN	ON: Normal communication OFF: Communication shut off (time expiration error)	L ERR.	ON: Communication data error Flash at regular intervals: Indicates that the station number setting or transmission speed setting switch position was changed while power is ON Flash at irregular intervals: When the setting of the terminal resistor is wrong; when the cable for the module or CC-Link is affected by noise OFF: Normal communication	X0 to 7 Y8 to F	ON: Input/Output ON OFF: Input/Output OFF																							
		LED name	Confirmation details																																
		PW	ON: Power supply ON OFF: Power supply OFF																																
		L RUN	ON: Normal communication OFF: Communication shut off (time expiration error)																																
L ERR.	ON: Communication data error Flash at regular intervals: Indicates that the station number setting or transmission speed setting switch position was changed while power is ON Flash at irregular intervals: When the setting of the terminal resistor is wrong; when the cable for the module or CC-Link is affected by noise OFF: Normal communication																																		
X0 to 7 Y8 to F	ON: Input/Output ON OFF: Input/Output OFF																																		
②	Transmission speed setting	<table border="1"> <thead> <tr> <th rowspan="2">Setting value</th> <th colspan="3">Setting switch status</th> <th rowspan="2">Transmission speed</th> </tr> <tr> <th>4</th> <th>2</th> <th>1</th> </tr> </thead> <tbody> <tr> <td>0</td> <td>OFF</td> <td>OFF</td> <td>OFF</td> <td>156 kbps</td> </tr> <tr> <td>1</td> <td>OFF</td> <td>OFF</td> <td>ON</td> <td>625 kbps</td> </tr> <tr> <td>2</td> <td>OFF</td> <td>ON</td> <td>OFF</td> <td>2.5 Mbps</td> </tr> <tr> <td>3</td> <td>OFF</td> <td>ON</td> <td>ON</td> <td>5.0 Mbps</td> </tr> <tr> <td>4</td> <td>ON</td> <td>OFF</td> <td>OFF</td> <td>10 Mbps</td> </tr> </tbody> </table> <p>Be sure to set the transmission speed within the above range.</p>	Setting value	Setting switch status			Transmission speed	4	2	1	0	OFF	OFF	OFF	156 kbps	1	OFF	OFF	ON	625 kbps	2	OFF	ON	OFF	2.5 Mbps	3	OFF	ON	ON	5.0 Mbps	4	ON	OFF	OFF	10 Mbps
Setting value	Setting switch status			Transmission speed																															
	4	2	1																																
0	OFF	OFF	OFF	156 kbps																															
1	OFF	OFF	ON	625 kbps																															
2	OFF	ON	OFF	2.5 Mbps																															
3	OFF	ON	ON	5.0 Mbps																															
4	ON	OFF	OFF	10 Mbps																															
③	Station number setting switches	<p>Select “10”, “20” or “40” to set the tens place of the station number. Select “1”, “2”, “4” or “8” to set the ones place of the station number. Always set the station number within the range of 1 to 64. (*1) (Example) Set the switches as below when setting the station number to 32:</p> <table border="1"> <thead> <tr> <th rowspan="2">Station number</th> <th colspan="3">Tens place</th> <th colspan="4">Ones place</th> </tr> <tr> <th>40</th> <th>20</th> <th>10</th> <th>8</th> <th>4</th> <th>2</th> <th>1</th> </tr> </thead> <tbody> <tr> <td>32</td> <td>OFF</td> <td>ON</td> <td>ON</td> <td>OFF</td> <td>OFF</td> <td>ON</td> <td>OFF</td> </tr> </tbody> </table>	Station number	Tens place			Ones place				40	20	10	8	4	2	1	32	OFF	ON	ON	OFF	OFF	ON	OFF										
Station number	Tens place			Ones place																															
	40	20	10	8	4	2	1																												
32	OFF	ON	ON	OFF	OFF	ON	OFF																												
④	Input response speed switching switches	<table border="1"> <thead> <tr> <th rowspan="2">Setting value</th> <th colspan="2">Setting switch status</th> <th rowspan="2">Input response speed</th> </tr> <tr> <th>2</th> <th>1</th> </tr> </thead> <tbody> <tr> <td>0</td> <td>OFF</td> <td>OFF</td> <td>10 ms</td> </tr> <tr> <td>1</td> <td>OFF</td> <td>ON</td> <td>5 ms</td> </tr> <tr> <td>2</td> <td>ON</td> <td>OFF</td> <td>1.5 ms</td> </tr> <tr> <td>3</td> <td>ON</td> <td>ON</td> <td>0.2 ms</td> </tr> </tbody> </table> <p>Setting switch is “2” (1.5 ms) at factory default setting. (*2)</p>	Setting value	Setting switch status		Input response speed	2	1	0	OFF	OFF	10 ms	1	OFF	ON	5 ms	2	ON	OFF	1.5 ms	3	ON	ON	0.2 ms											
Setting value	Setting switch status			Input response speed																															
	2	1																																	
0	OFF	OFF	10 ms																																
1	OFF	ON	5 ms																																
2	ON	OFF	1.5 ms																																
3	ON	ON	0.2 ms																																
⑤	Terminal block	A terminal block for connection to the power supply, transmission and I/O signals.																																	
⑥	Hook for DIN rail	When the module is installed to the DIN rail, push on the center line of the hook for DIN rail with a finger tip until a clicking sound is heard.																																	

*1: Duplicate station number cannot be set.

*2: Setting of switch is reflected/held by power-on. When setting of switch is changed while the power supply is ON, turn OFF and turn ON power supply again.